

CHE

HEAT TRANSFER PRODUCTS

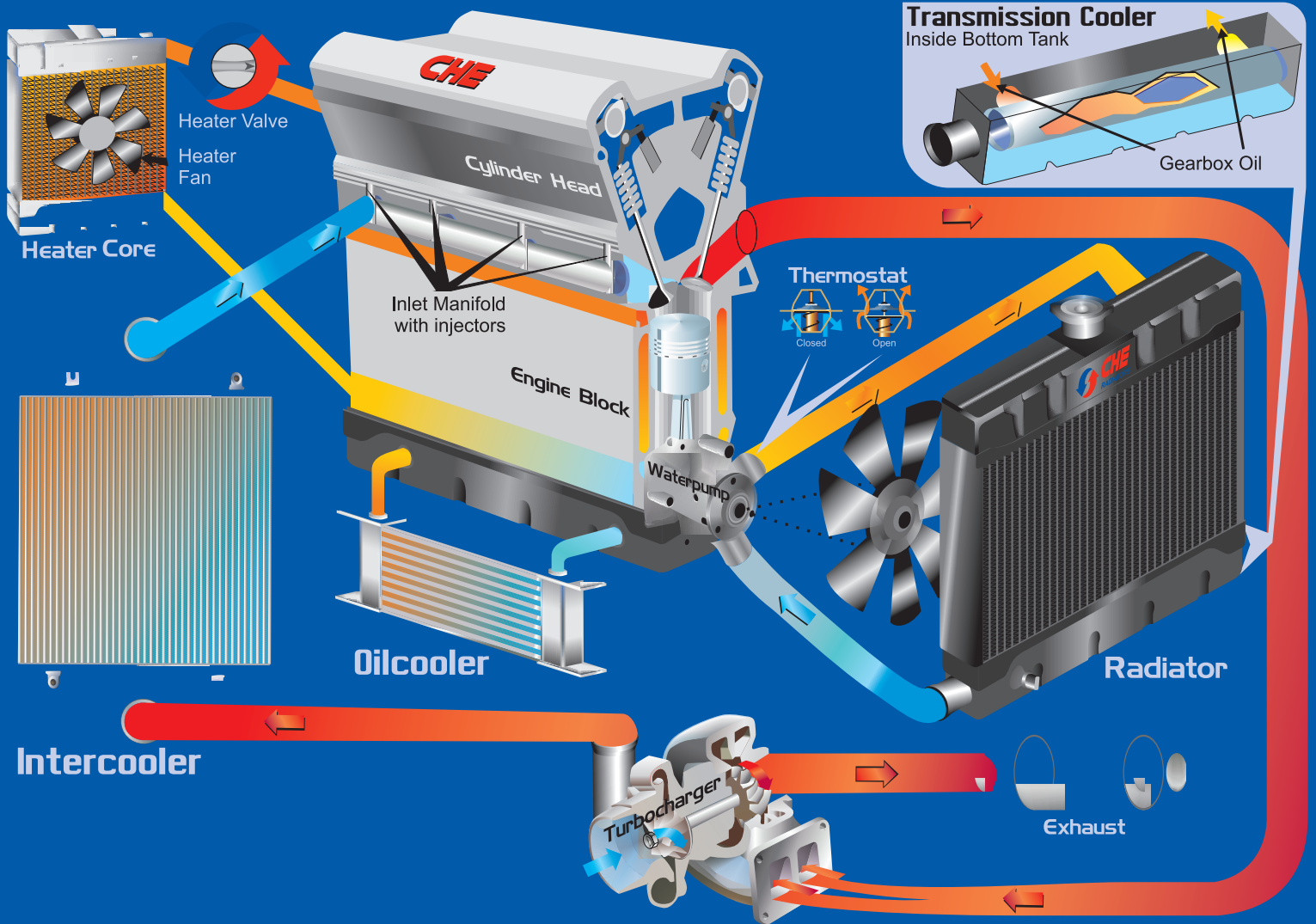

2019 Catalogue

www.CHE.co.za

CONTENTS

1.INTRODUCTION

2.OIL COOLERS

ATLAS COPCO
BELL
CATERPILLAR
GALLION
HYDROVANE
HYUNDAI
INGERSOL RAND
JOHN DEERE
LINDE
MAGIRUS
MAN
MERCEDES BENZ
NISSAN
SB COOLER
SCANIA
SUZUKI
TOYOTA
ZIP COOLERS

3.TRANSMISSION COOLERS

FORD
HYSTER
LAND ROVER
MAN
MERCEDES BENZ

4.RADIATORS

AUSTIN
BELL
CATERPILLAR
FREIGHTLINER
HITACHI
INTERNATIONAL
ISUZU
KOMATSU
MAHINDRA
MAN
MORGAN
NISSAN
SWIMMING POOL
TOYOTA
VOLVO

5.INTERCOOLERS

BELL
FORD
ISUZU
LAND ROVER
MAZDA
MINI
TOYOTA
VOLKSWAGEN

INTRODUCTION

1. Background

a. Company History

Cape Heat Exchange (Pty) Ltd is situated in Paarl, South Africa, about 50 km outside of Cape Town. The company traces its origins back to the establishment of Cape Radiators in 1968. This year the company celebrated its 20th year of existence, and this clearly positions us as a stabilized company in the heat transfer field.

b. What we do

We are an independently established and dynamic company that develops, manufactures and markets heat exchangers for use in various original equipment manufacturer (OEM) applications, the automotive industry and industrial aftermarkets.

2. Strategy & Vision

a. Vision & objectives

Our vision and objectives are to expand and diversify product lines through continuous and innovative improvement, not only product development but also keeping up to date with the latest machinery.

b. Mission statement

Our product quality is a direct result of the many years' experience and the use of the most modern techniques and advances in heat transfer technology (HTT). Our product diversity and experience gains us the recognition of South Africa's most complete supplier of high quality radiator products and industrial coolers. We not only manufacture new products but are also able to repair, clean and test heat exchangers. We also have a fully functional radiator shop on site and is able to help customers while they wait.

c. Values

Customer service through superlative service. In that we strive to work with a client to meet their requirements no matter the specifications.



INTRODUCTION

d. Growth strategy

To adapt to ever changing nature of the industry and the versatility of the field that we supply.

3. Products & Services

a. Products

Our products include the following:

- * Inter coolers
- * Tube & shell oil coolers
- * All types of marine coolers
- * Hydraulic oil coolers
- * Automotive oil coolers
- * Steam heat exchangers
- * Oil coolers in various designs
- * Heavy duty radiator cores
- * Special application radiator cores
- * Aftercoolers
- * Plastic & brass radiator tanks
- * Spiral tubes
- * Withnell tube oil coolers
- * Transmission oil coolers

b. Services

Manufacturing of new heat transfer products, but also the clean, test and repair of older products. Furthermore the radiator shop are able to handle and help walk in customers that have an emergency or whether they are in need for some expert advice.

c. Business competitiveness

We have a number of warehouses throughout South Africa and this enables us to reach a broader client base and also supply clients more effectively no matter their location. Our company is the only manufacturer of NCN aluminium heat exchanger in Africa. We are able to manufacture aluminium heat exchangers to client specifications

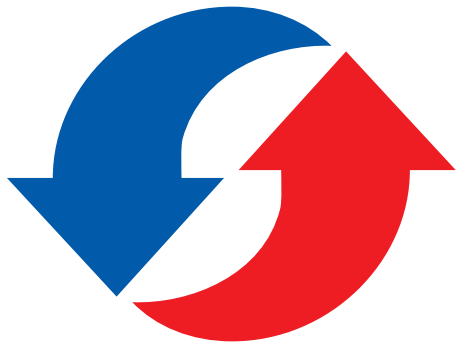

CHE

HEAT TRANSFER PRODUCTS

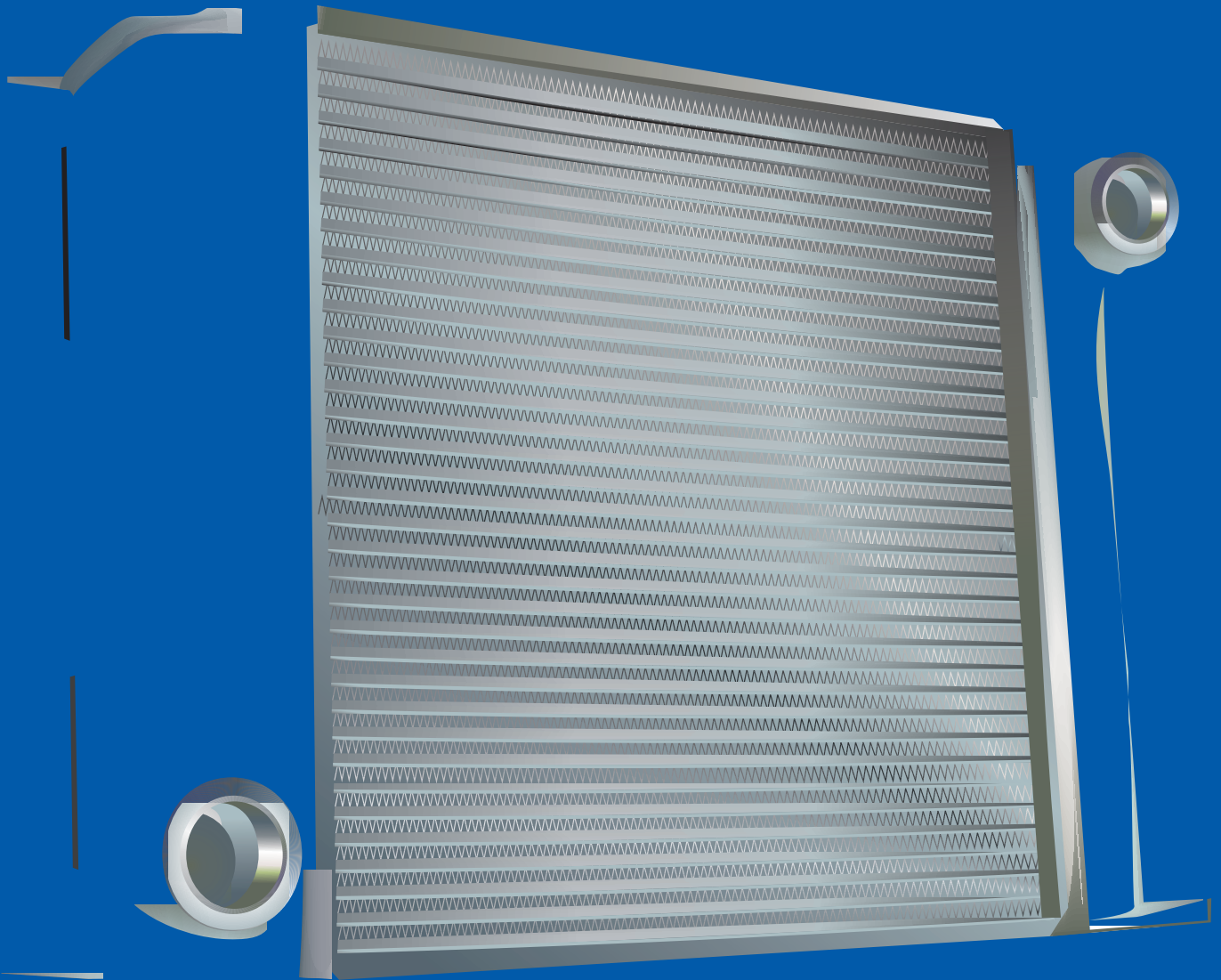

OILCOOLERS

www.CHE.co.za

OILCOOLER-ATLAS COPCO

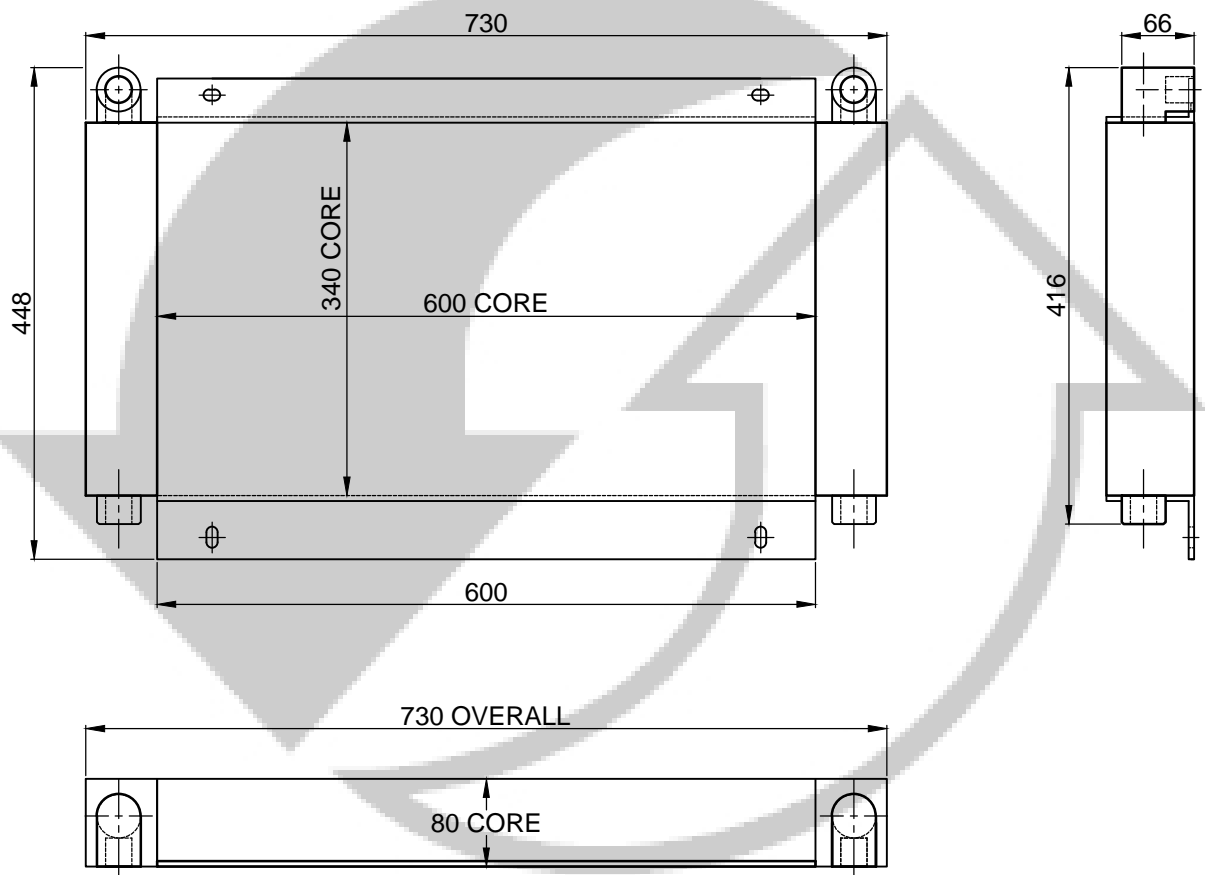

MODEL:ATLAS COPCO XA 85

PART NUMBER:OIL614ATL1COM

OILCOOLER-ATLAS COPCO

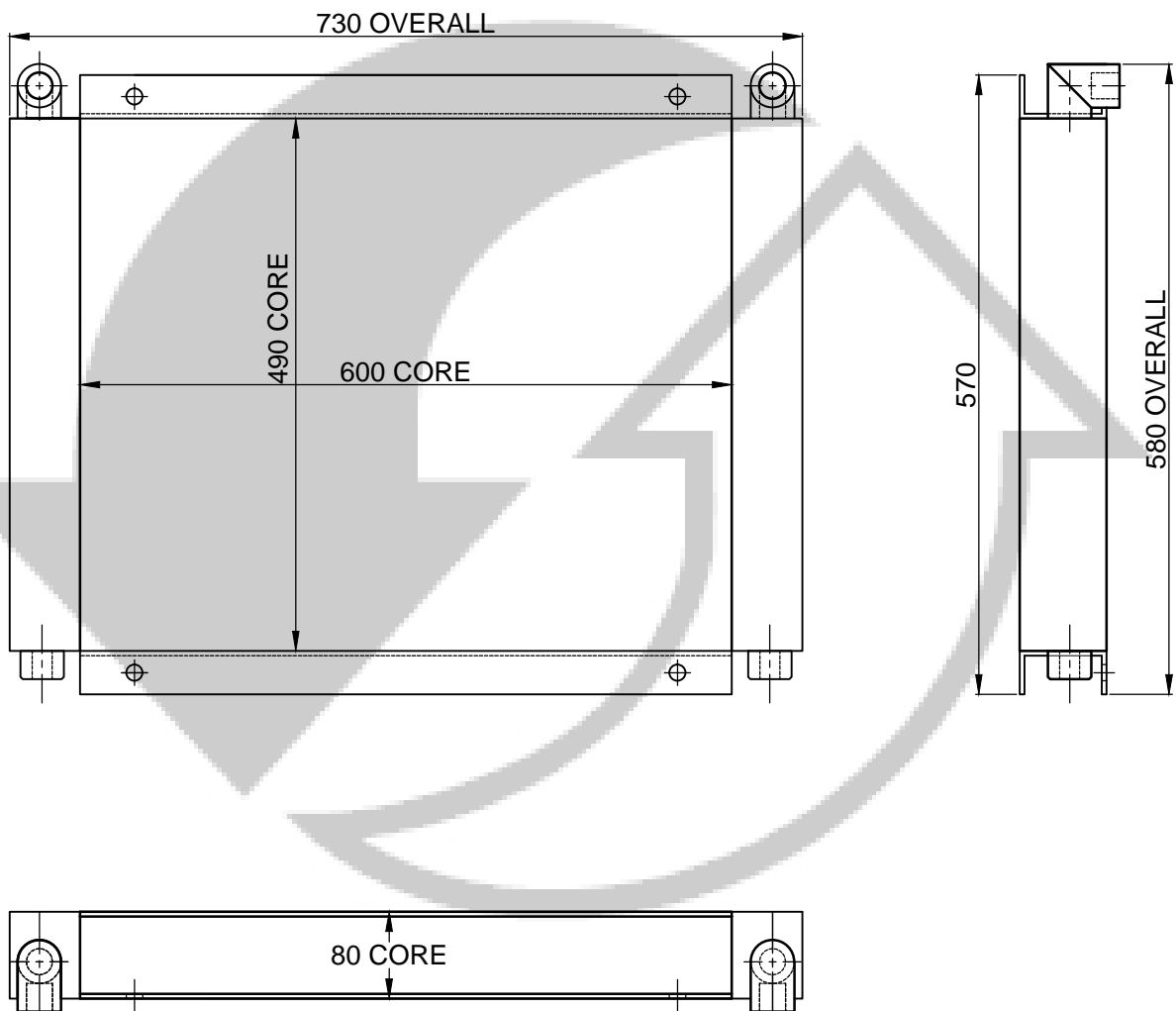

MODEL:ATLAS COPCO

PART NUMBER:OIL614ATL3COM

OILCOOLER-ATLAS COPCO

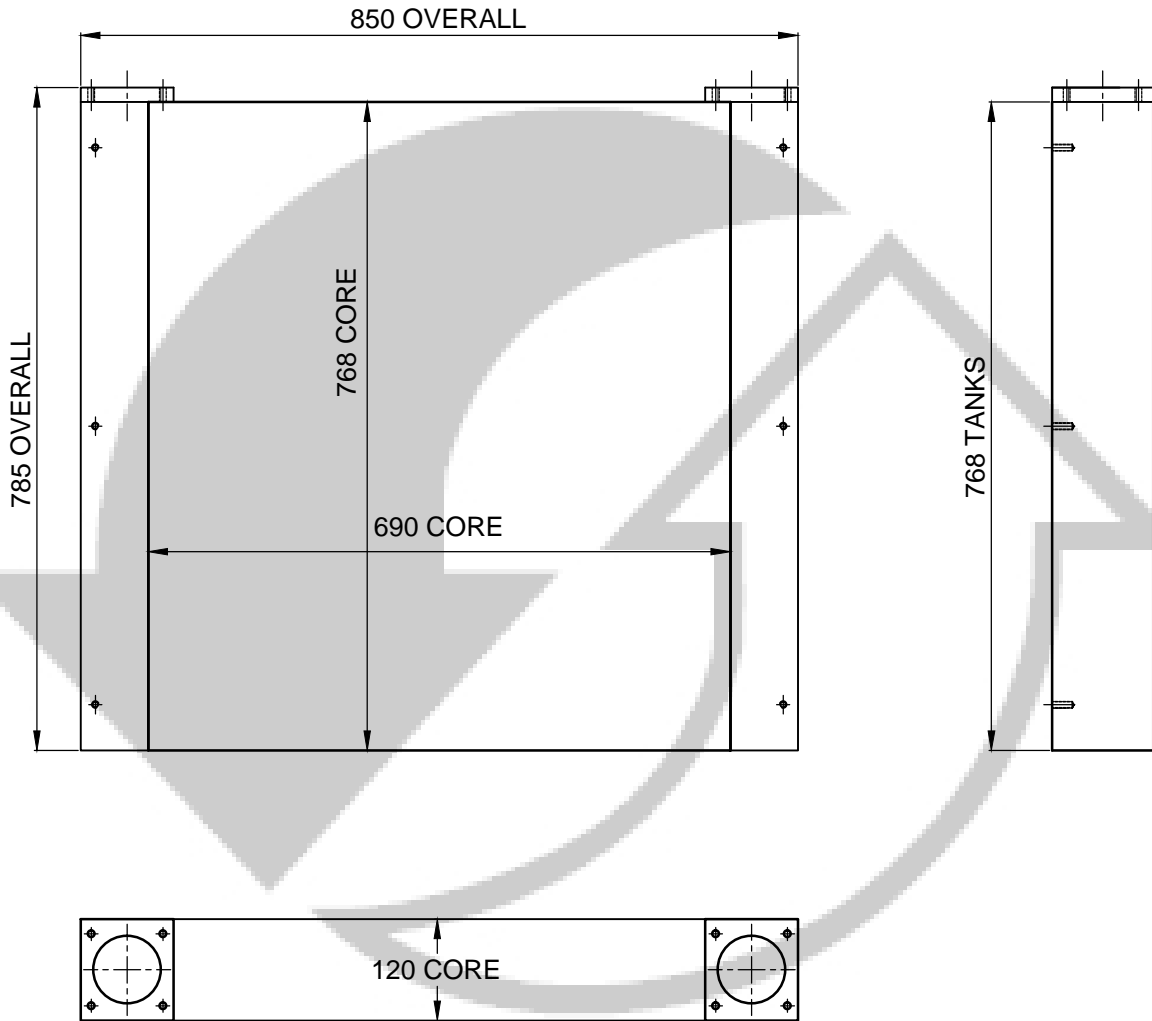

MODEL:ATLAS COPCO

PART NUMBER:OIL684ATL1COM

OILCOOLER-BELL

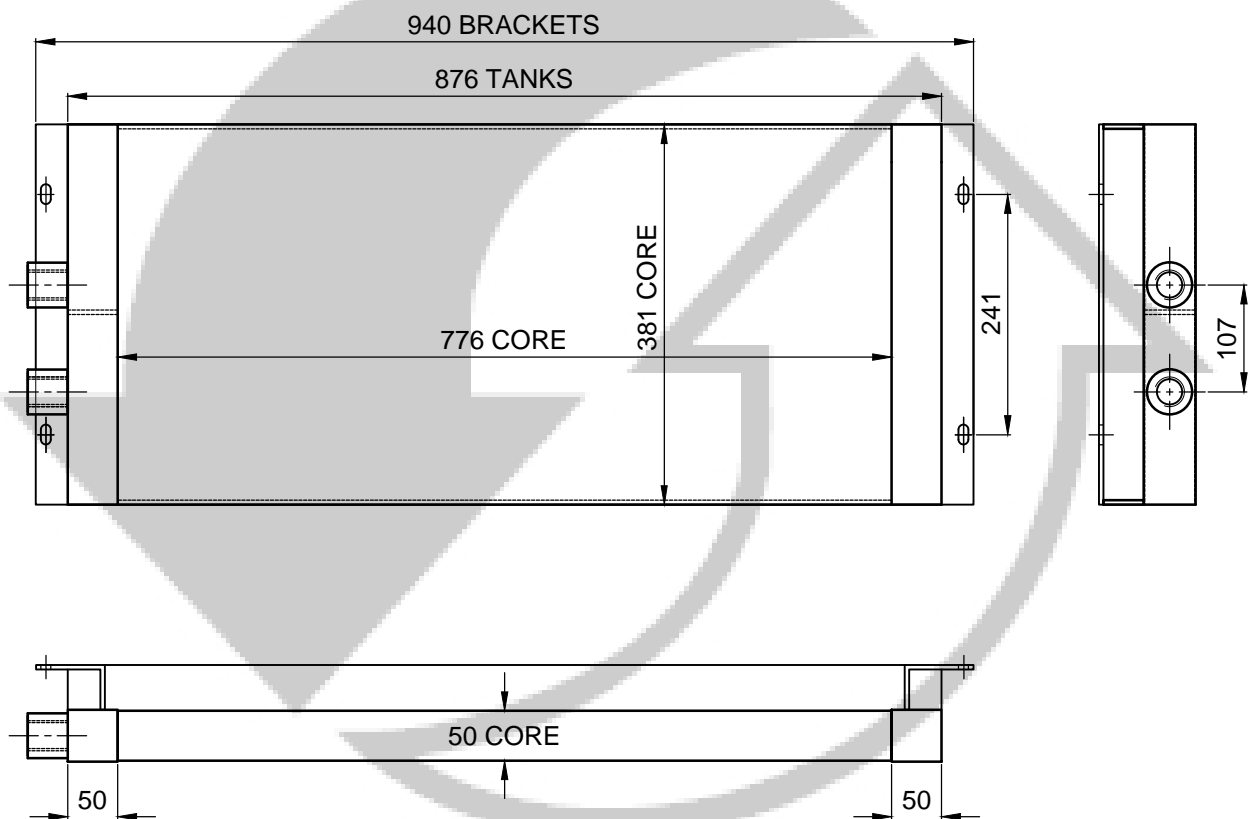

MODEL: BELL B25_API

PART NUMBER: OIL760BEL1COM

OILCOOLER-BELL

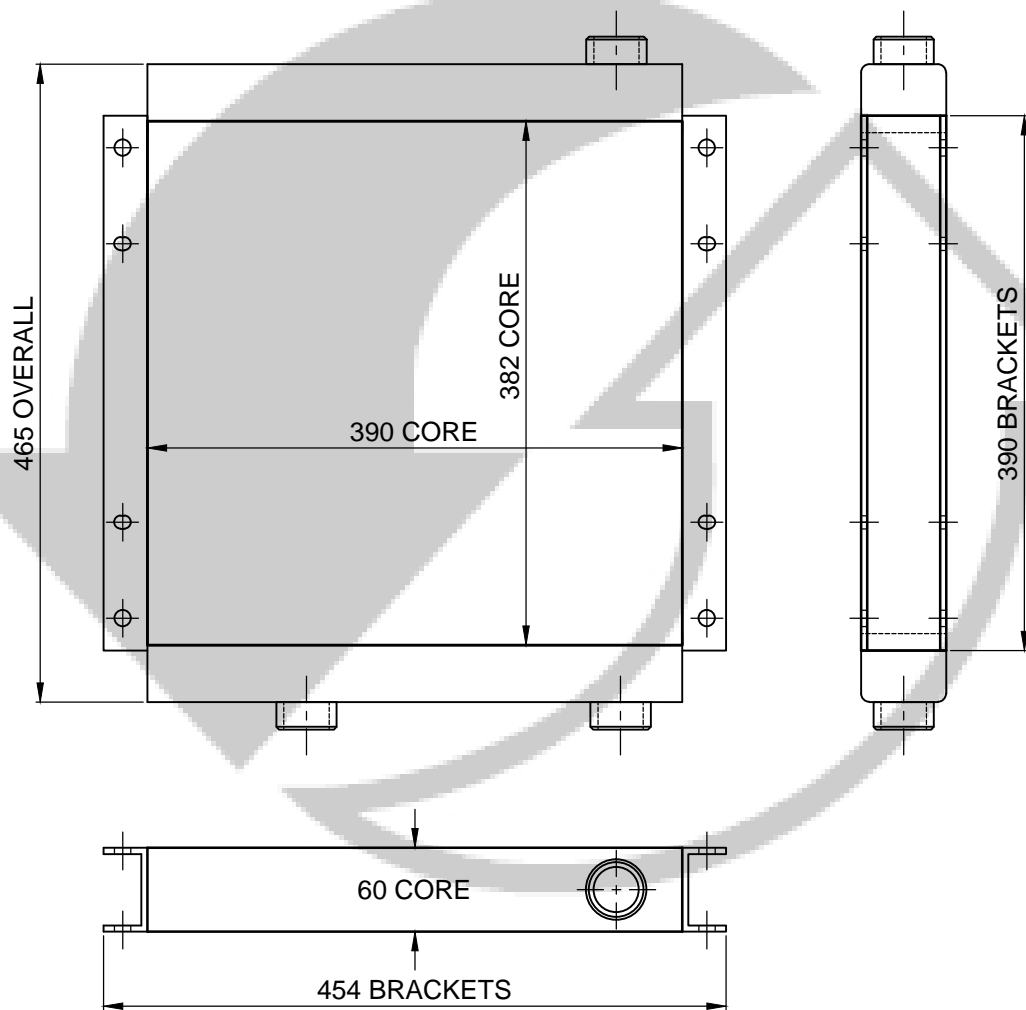

MODEL: BELL-B40

PART NUMBER: OIL390BEL1COM

OILCOOLER-BELL

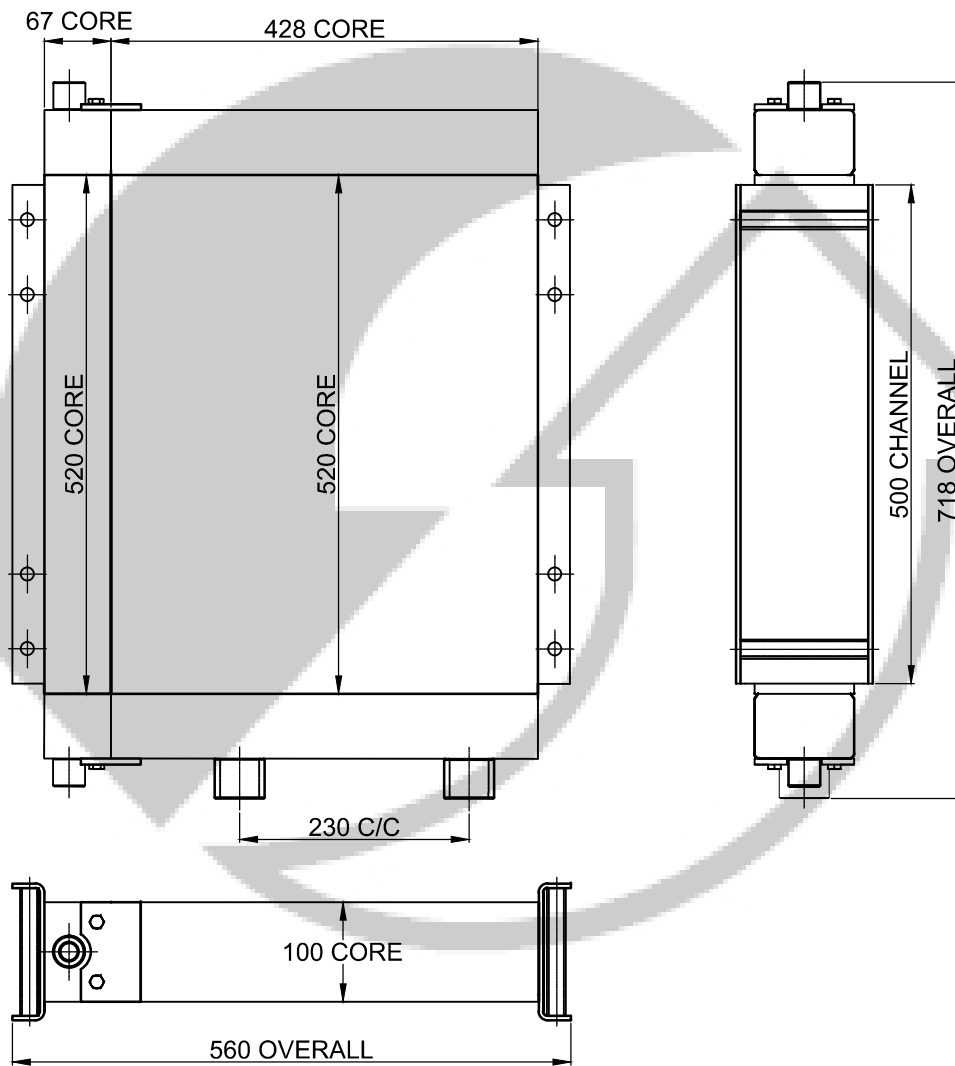

MODEL: BELL

PART NUMBER: OIL533BEL1COM

OILCOOLER-BELL

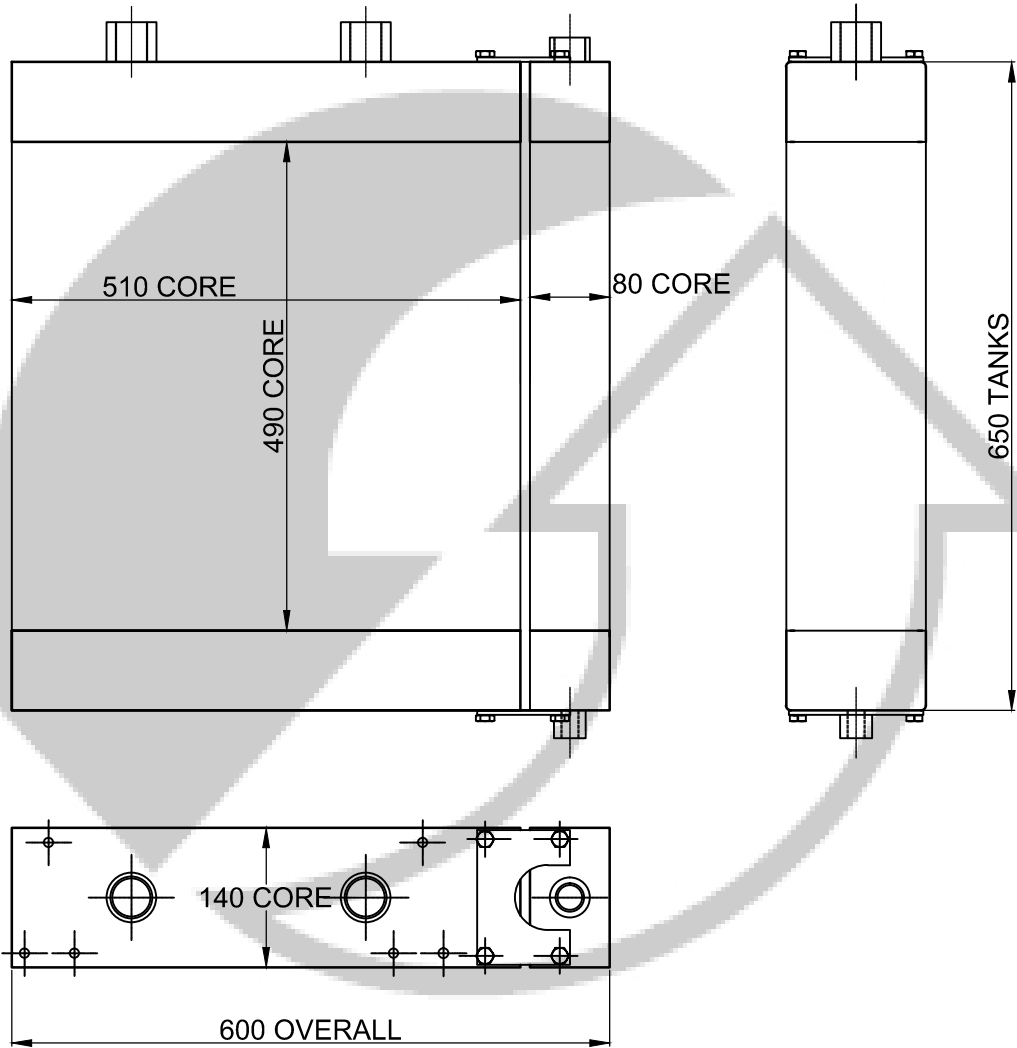

MODEL: BELL

PART NUMBER: OIL490BEL1COM

OILCOOLER-CATERPILLAR

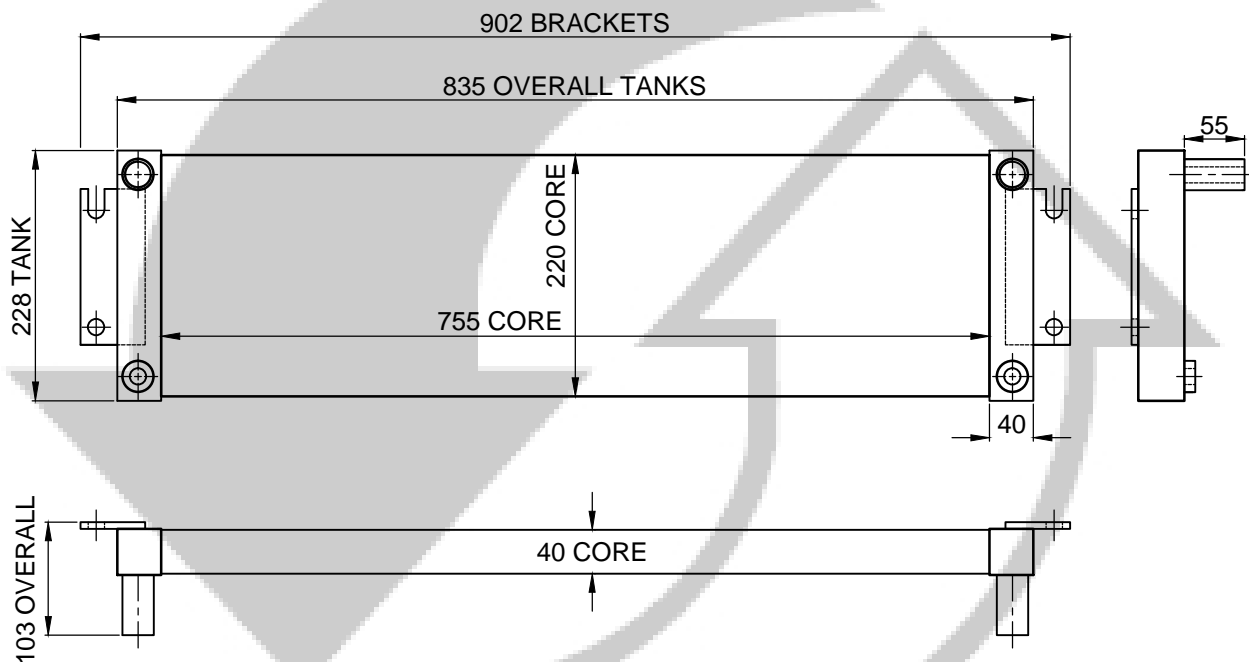

ORIGINAL UNIT IS A STEEL UNIT.



MODEL:CATERPILLAR 140G

PART NUMBER:OIL739CAT1COM

OILCOOLER-CAT

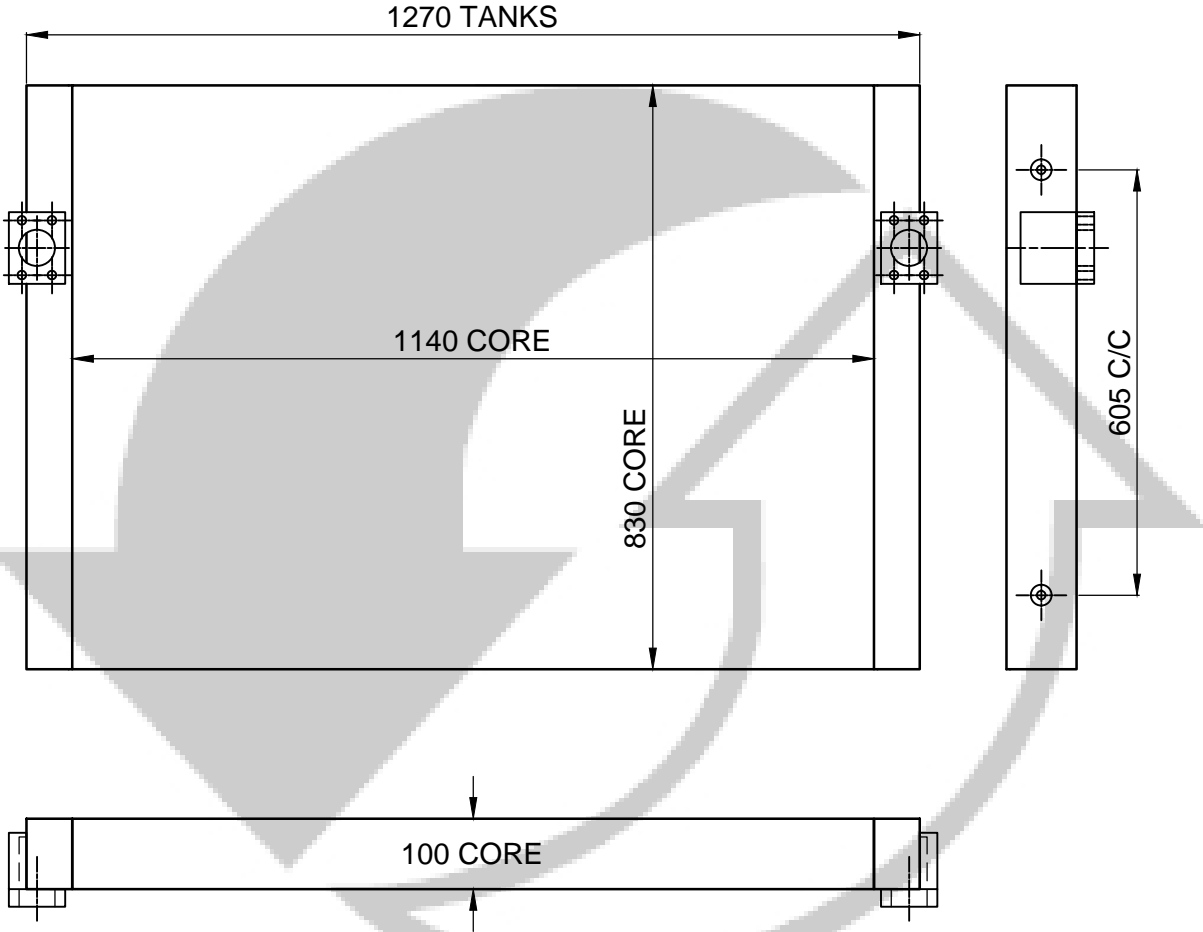

MODEL: CAT 345D EXCAVATOR

PART NUMBER: OIL1140CAT1COM

OILCOOLER-GALLION

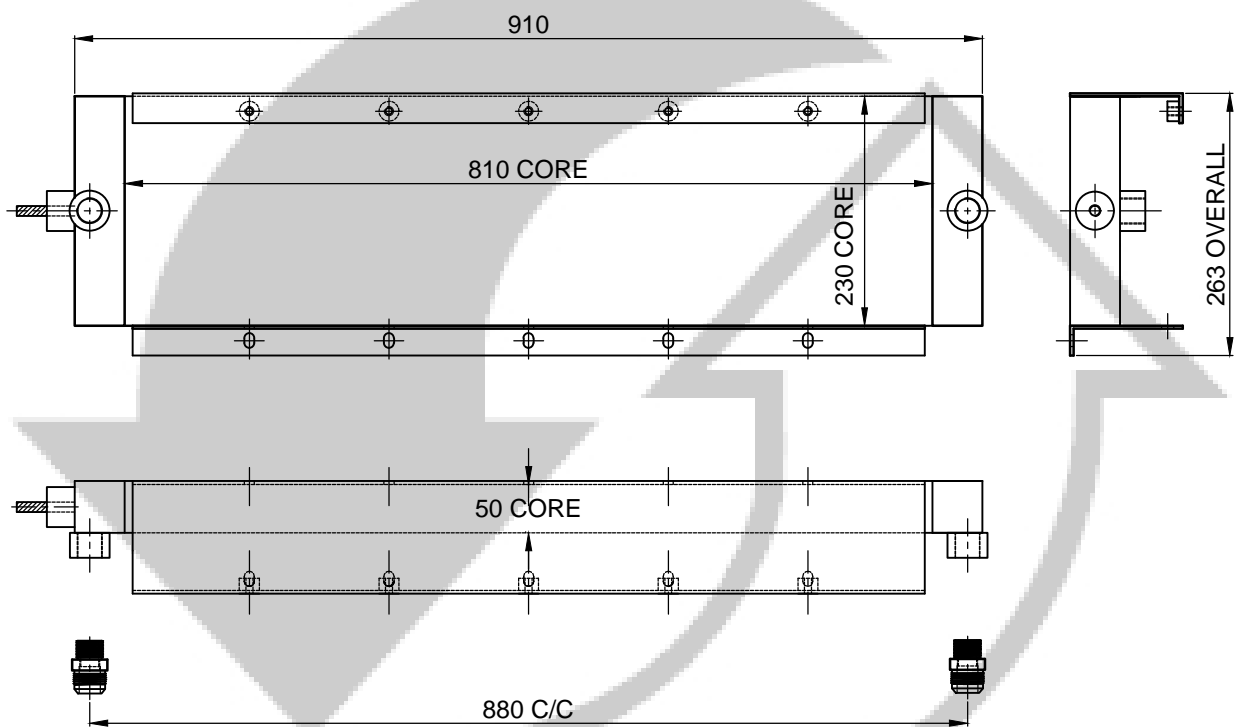

ORIGINAL UNIT IS A STEEL UNIT.



MODEL:GALLION T500/T600

PART NUMBER:OIL794GAL1COM

OILCOOLER-HYDROVANE

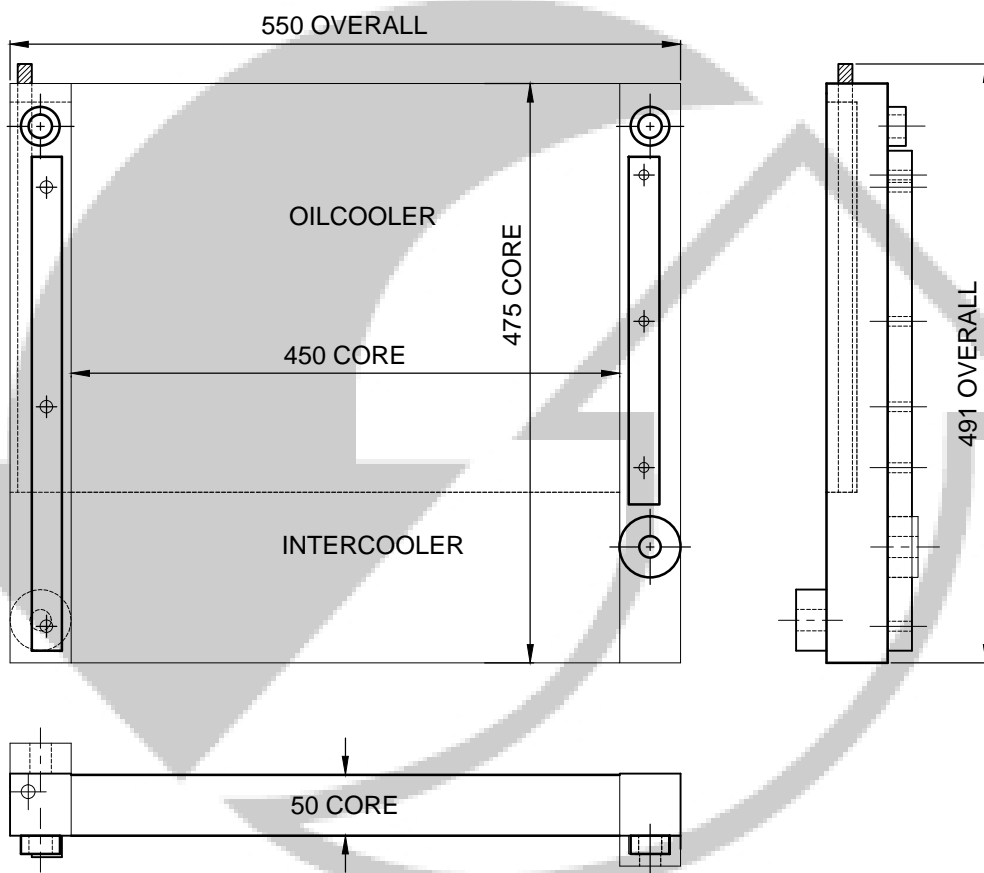

MODEL:HYDROVANE

PART NUMBER:OIL434HYD1COM

OILCOOLER-HYDROVANE

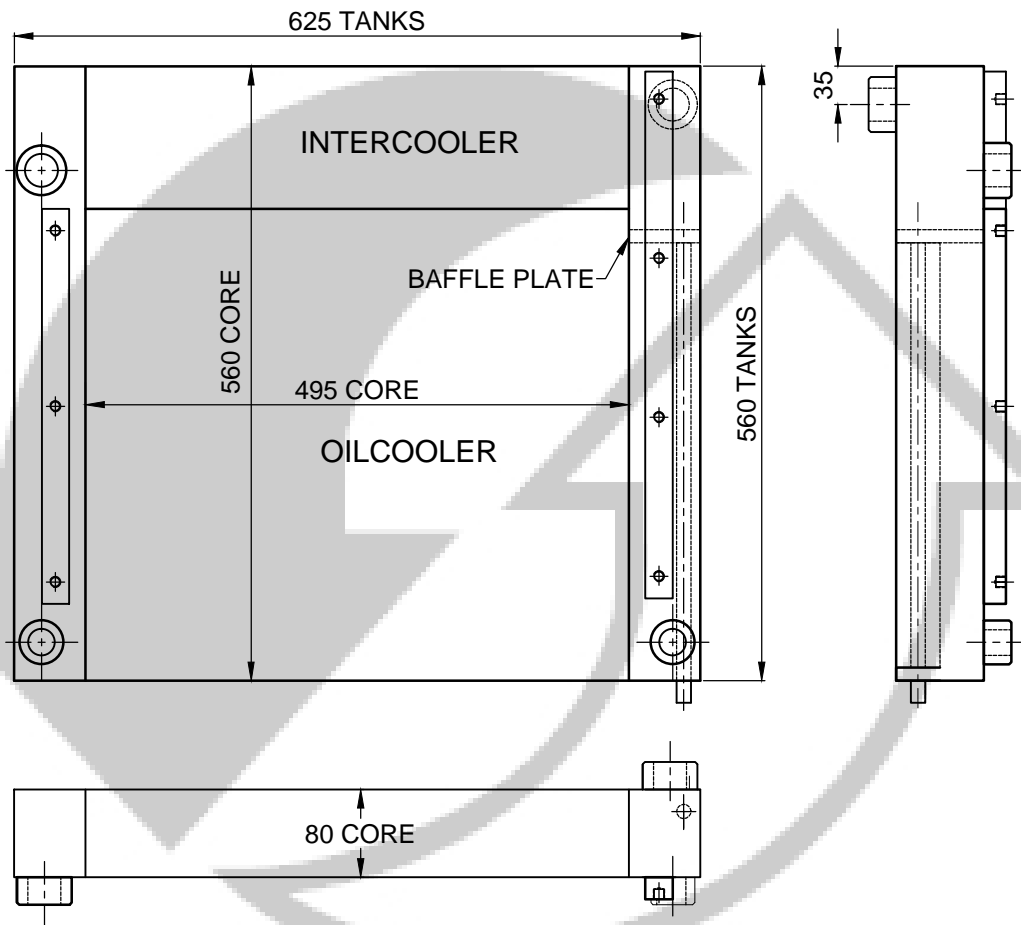

MODEL:HYDROVANE

PART NUMBER:OIL509HYD1COM

OILCOOLER-HYDROVANE

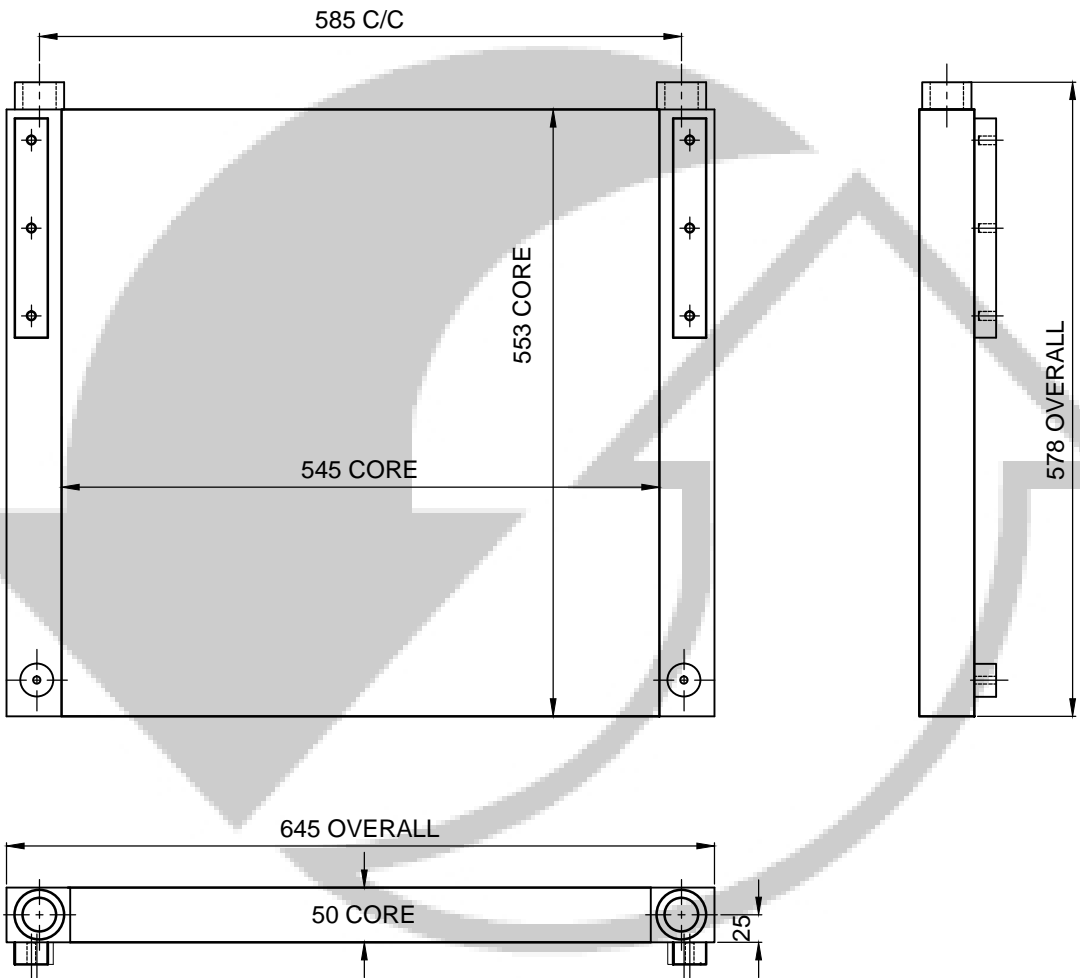

MODEL:HYDROVANE

PART NUMBER:OIL529HYD1COM

OILCOOLER-HYDROVANE

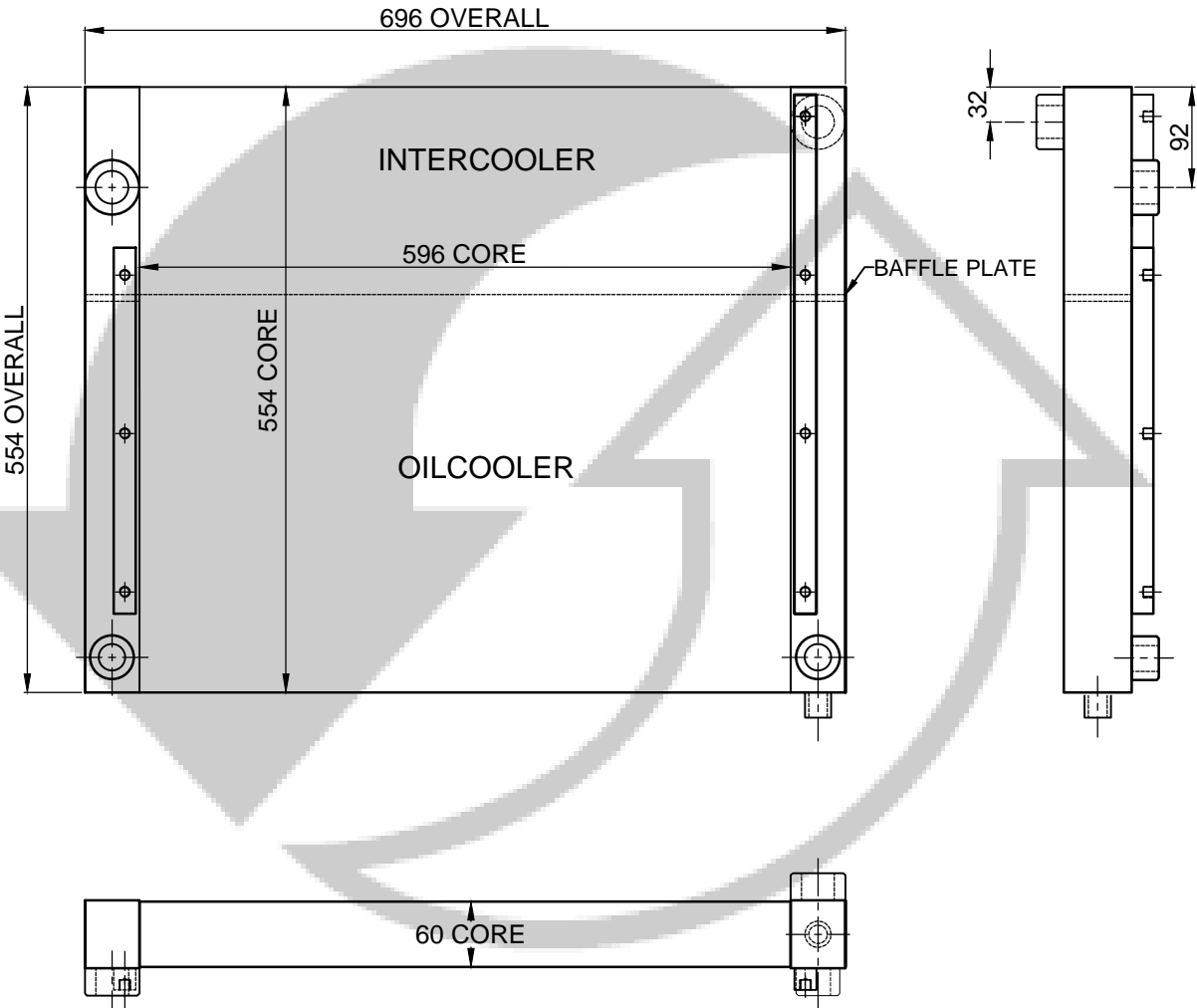

MODEL:HYDROVANE

PART NUMBER:OIL580HYD1COM

OILCOOLER-HYDROVANE

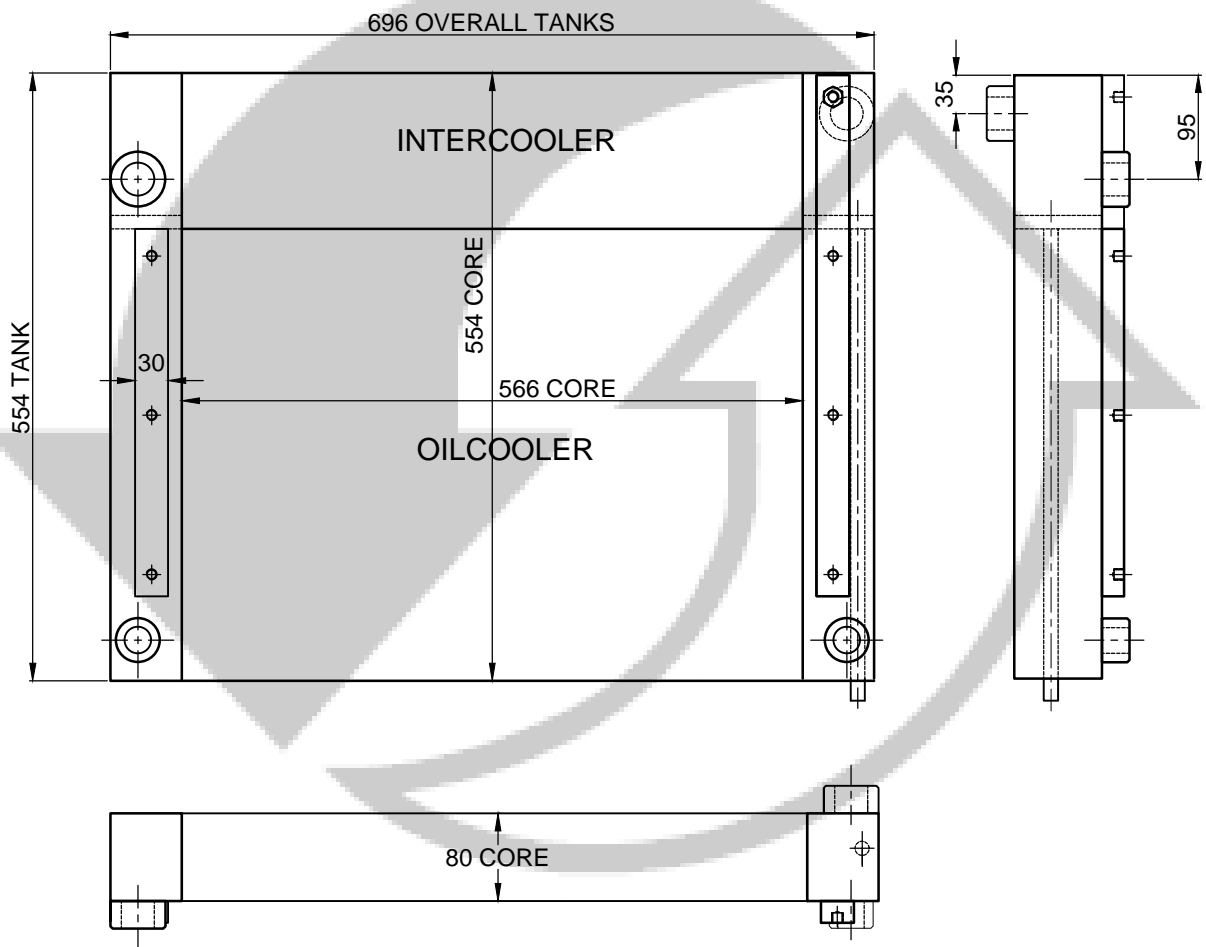

MODEL:HYDROVANE

PART NUMBER:OIL580HYD3COM

OILCOOLER-HYDROVANE

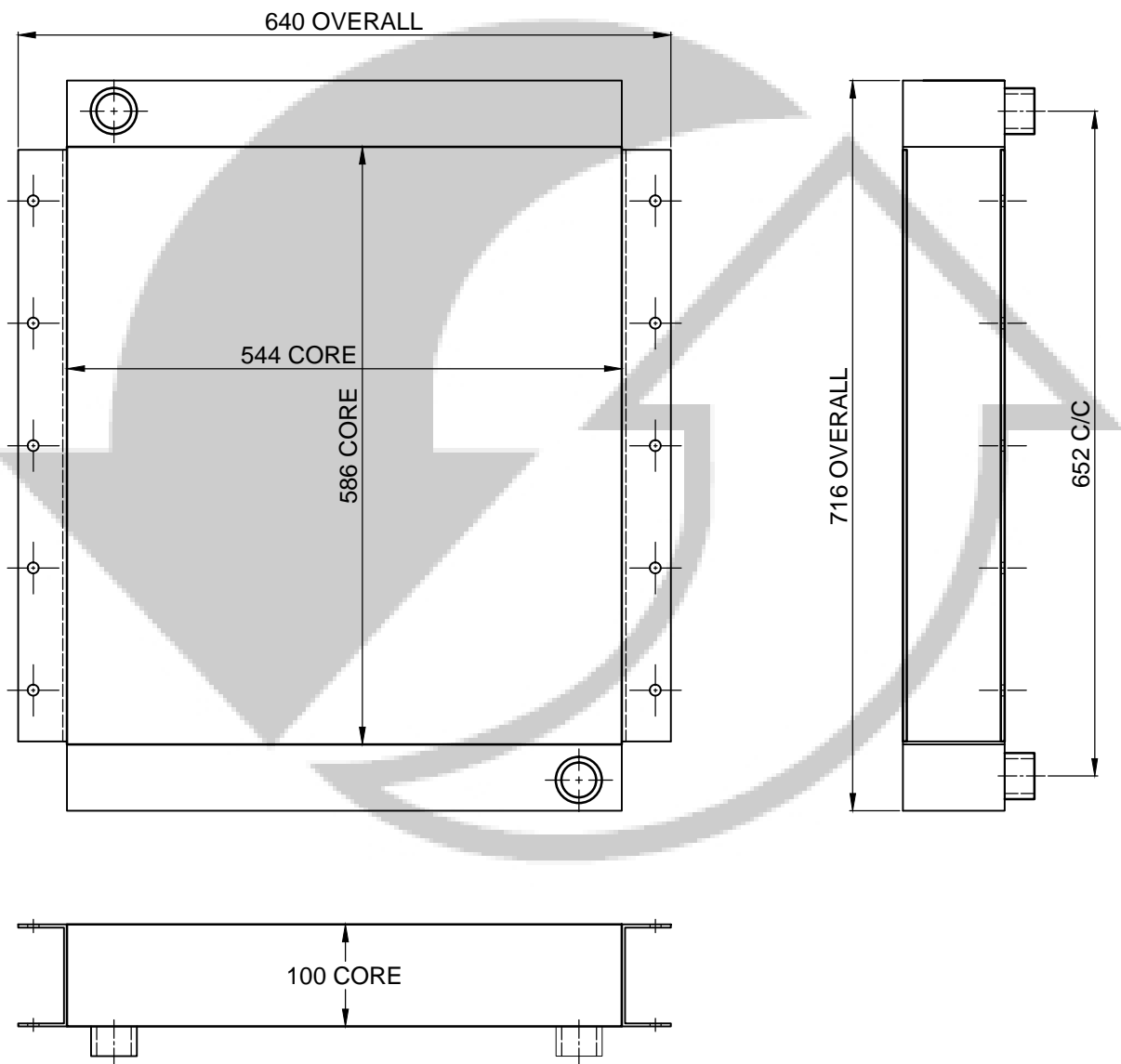

MODEL:HYDROVANE

PART NUMBER:OIL600HYD1COM

OILCOOLER-HYDROVANE

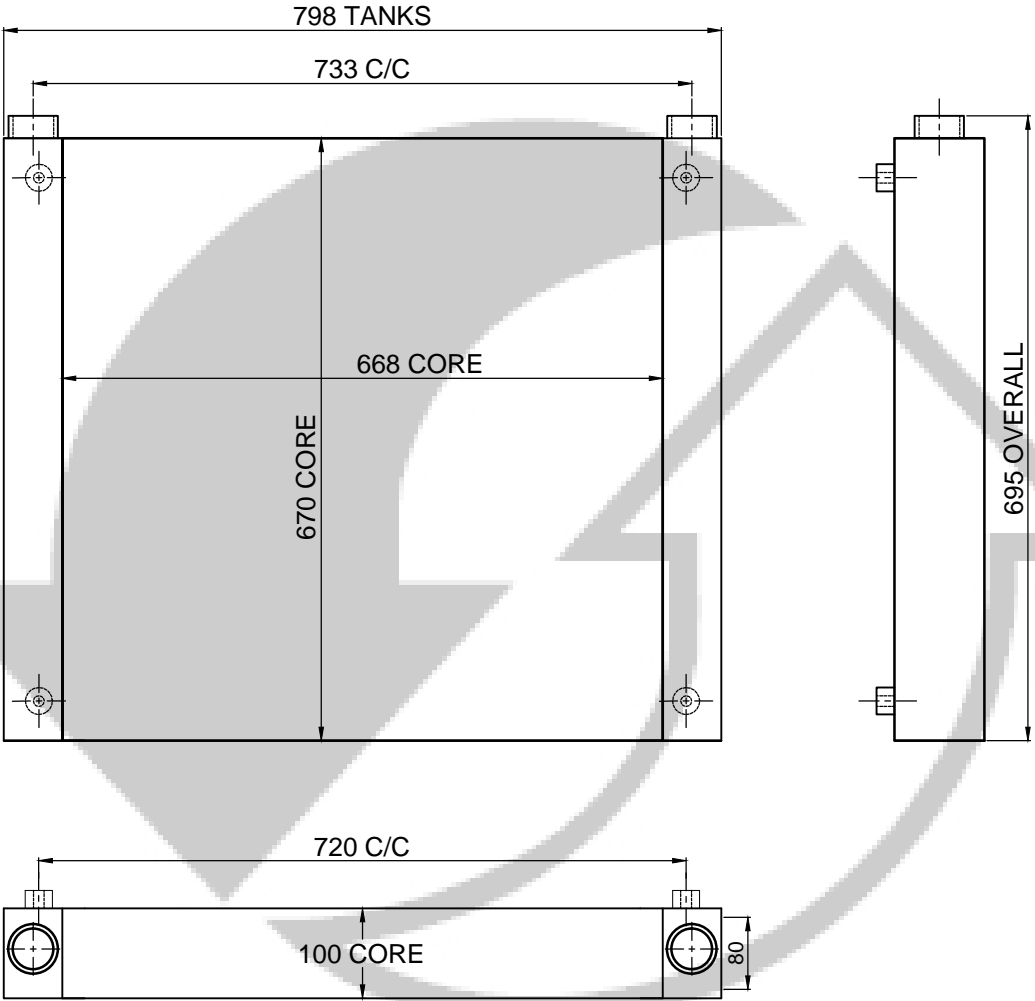

MODEL:HYDROVANE

PART NUMBER:OIL602 HYD1COM

OILCOOLER-HYDROVANE

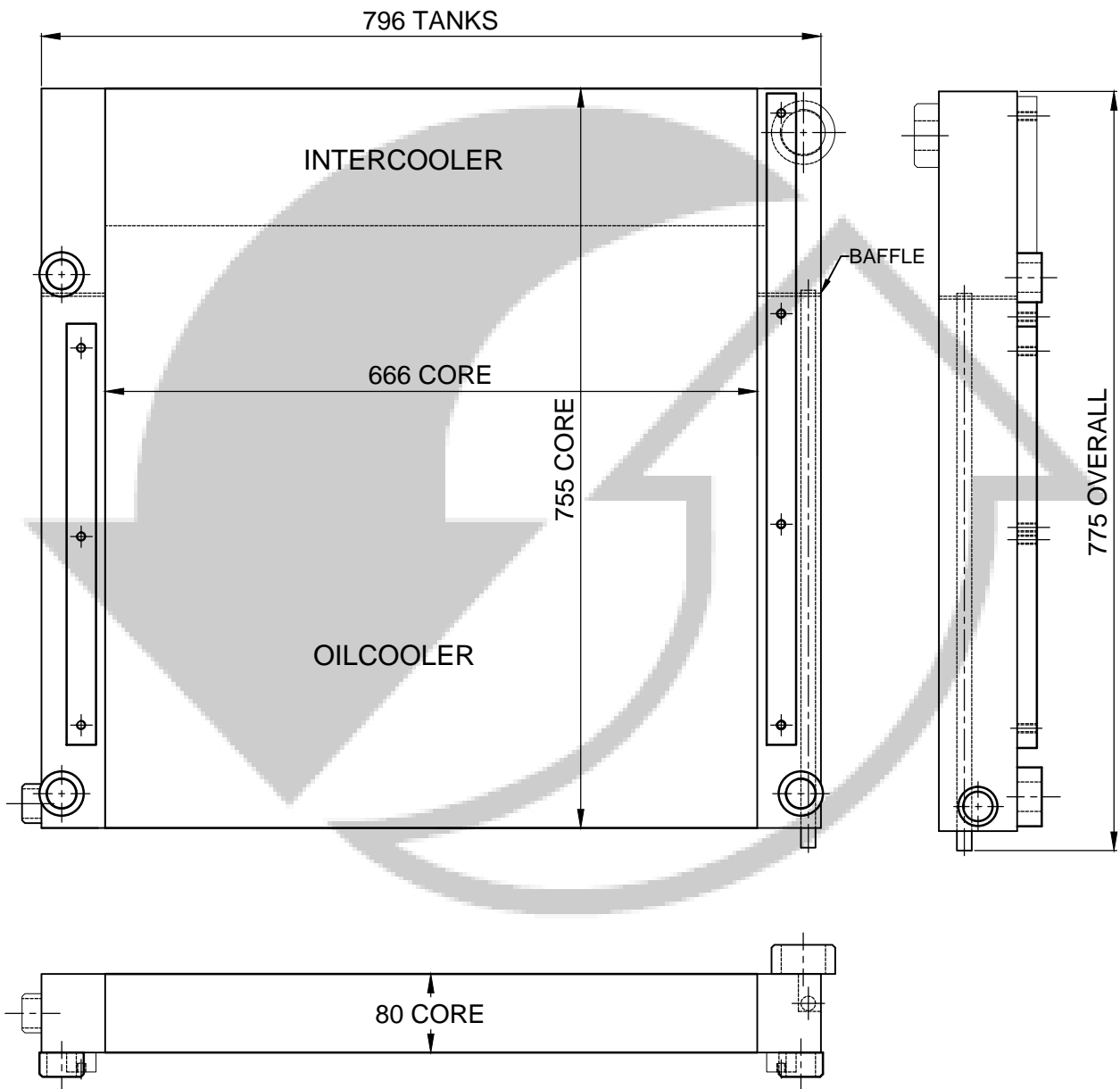

MODEL:HYDROVANE

PART NUMBER:OIL680HYD1COM

OILCOOLER-HYUNDAI

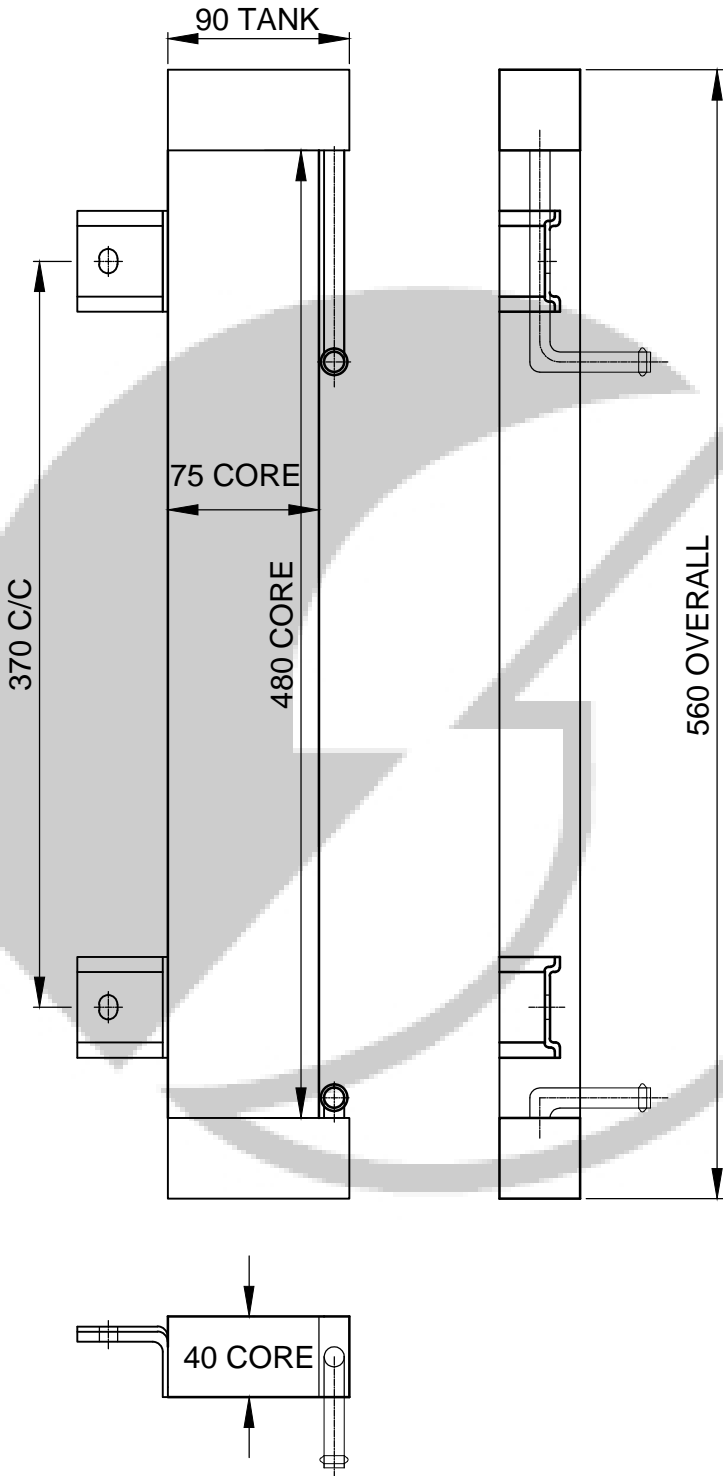

MODEL:HYUNDAI

PART NUMBER:OIL484HYU1COM

OILCOOLER-INGERSOL RAND

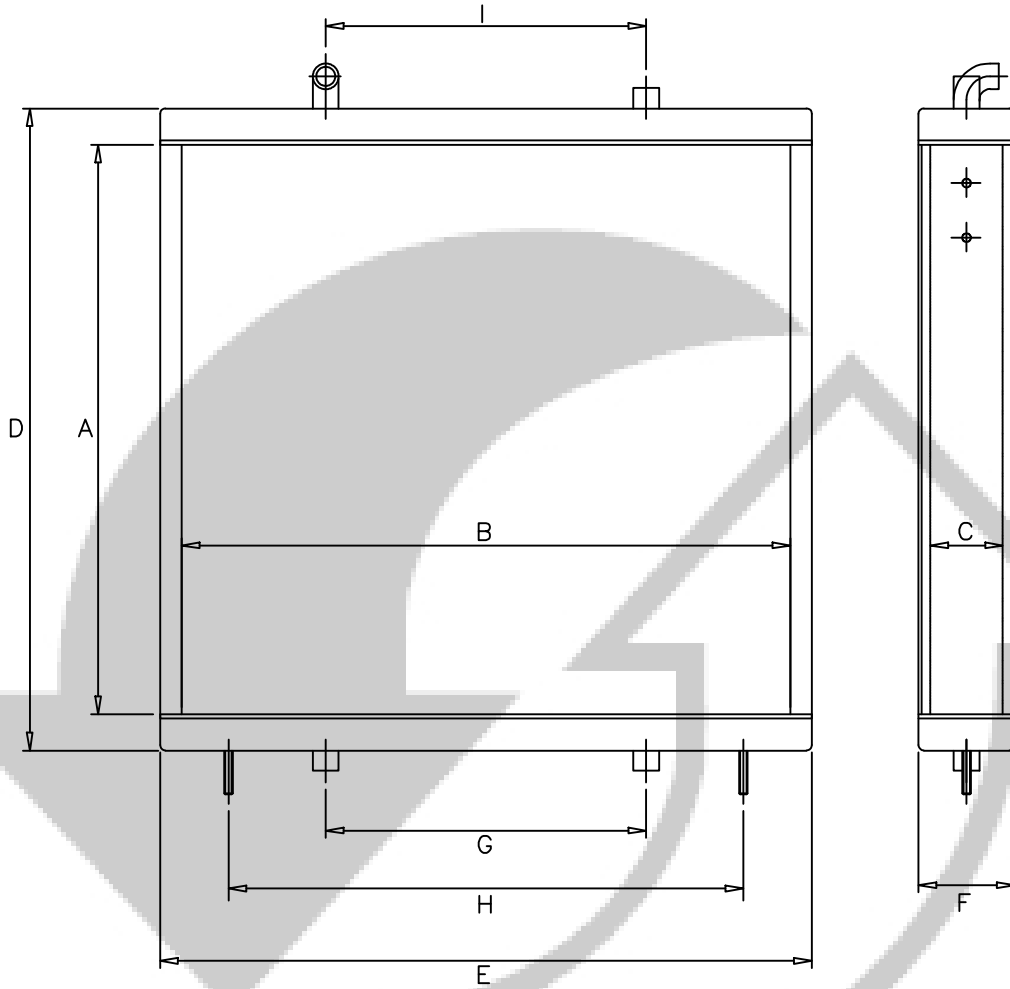

MODEL	CORE			OVERALL			OTHER			PART
	A	B	C	D	E	F	G	H	I	
533ING1	501	587	60	601	610	60	300	482	374	533ING1
584ING1	556	682	60	656	727	60	276	628	508	584ING1
686ING1	658	758	60	758	799	60	251	705	508	686ING1
838ING1	870	910	60	970	971	60	317	673	-	838ING1



MODEL:INGERSOL RAND DR 125,210,250,365
 PART NUMBER:OIL533ING1COM,OIL5841COM,
 OIL686ING1COM,OIL8381COM

OILCOOLER-INGERSOL RAND

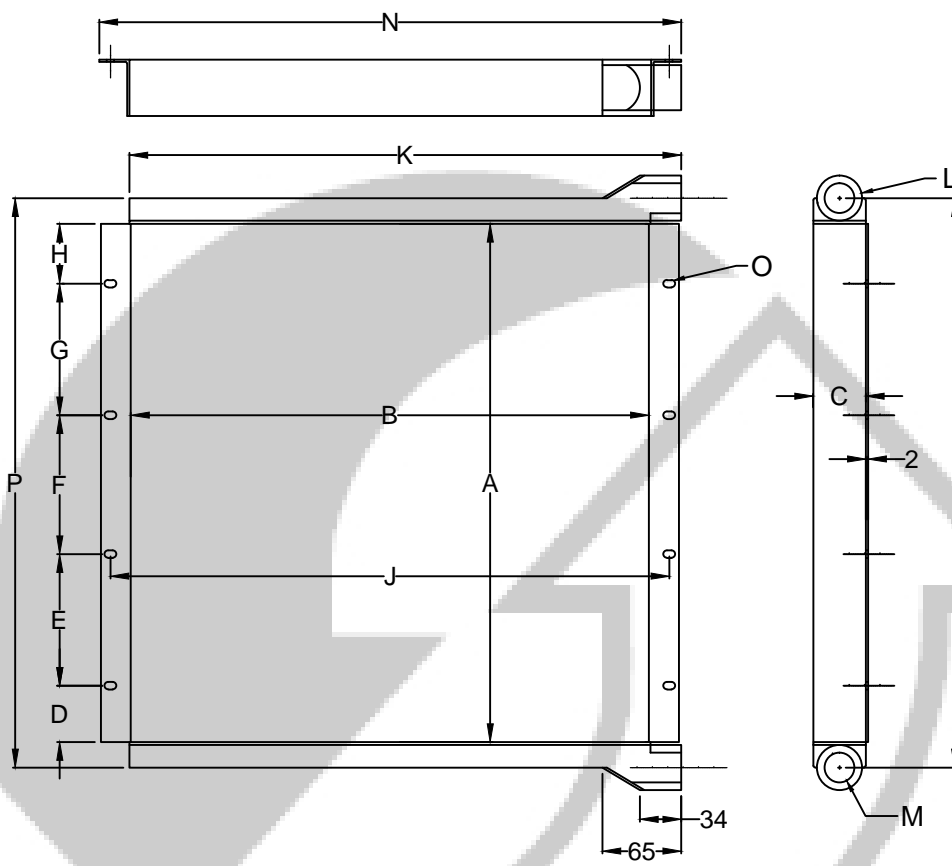

A	B	C	D	E	F	G	H	I	J	K	L	M	N	O	P
895	910	60	76.5	254	254	254	76.5	995	865	860	Ø57	1½"NPT	890	12x8 slot	995
735	728	60	38	228	228	228	38	845	768	765	Ø60	1½"NPT	798	12x8 slot	835



MODEL:INGERSOL RAND

PART NUMBER:915 ING1,760ING1

OILCOOLER-JOHN DEERE

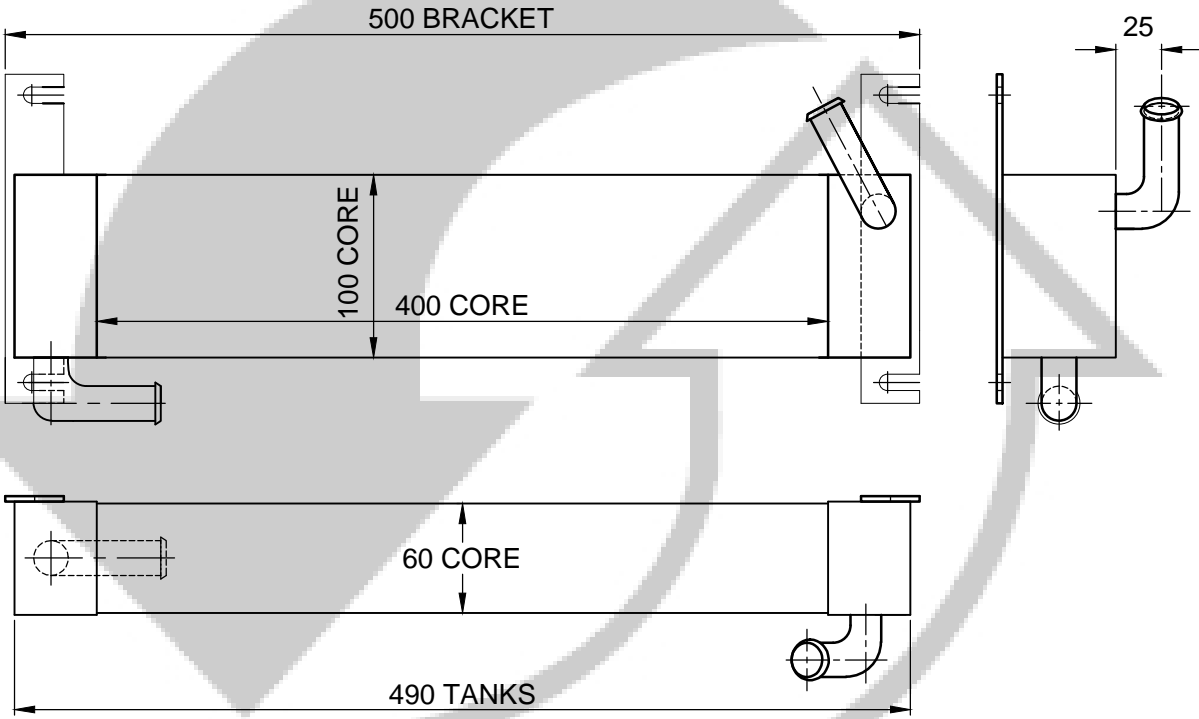

MODEL:JOHN DEERE

PART NUMBER:OIL400JOH1COM

OILCOOLER-JOHN DEERE

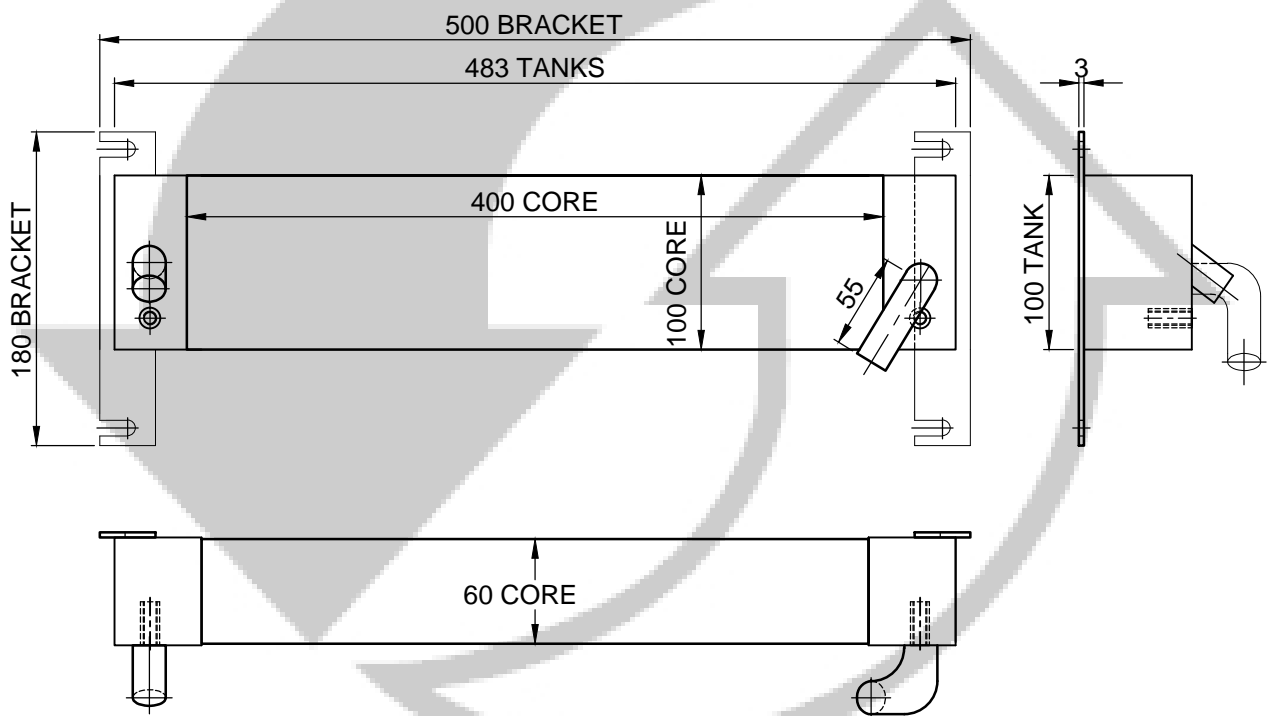

MODEL:JOHN DEERE

PART NUMBER:OIL400JOH2COM

OILCOOLER-JOHN DEERE

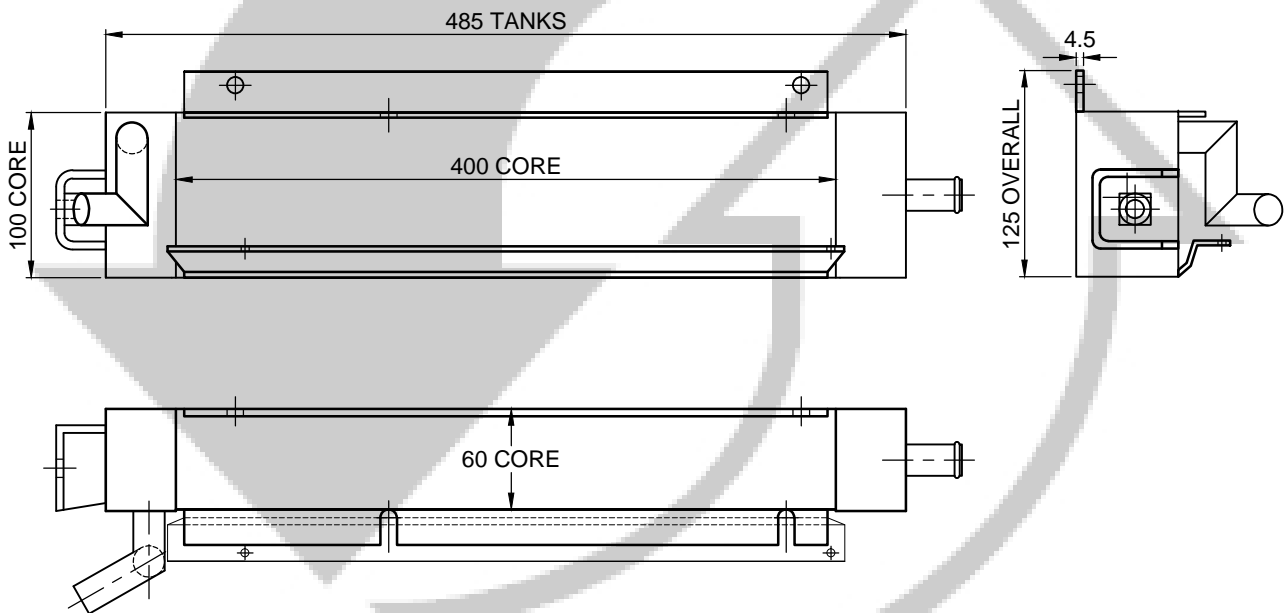

MODEL:JOHN DEERE

PART NUMBER:OIL400JOH3COM

OILCOOLER-JOHN DEERE

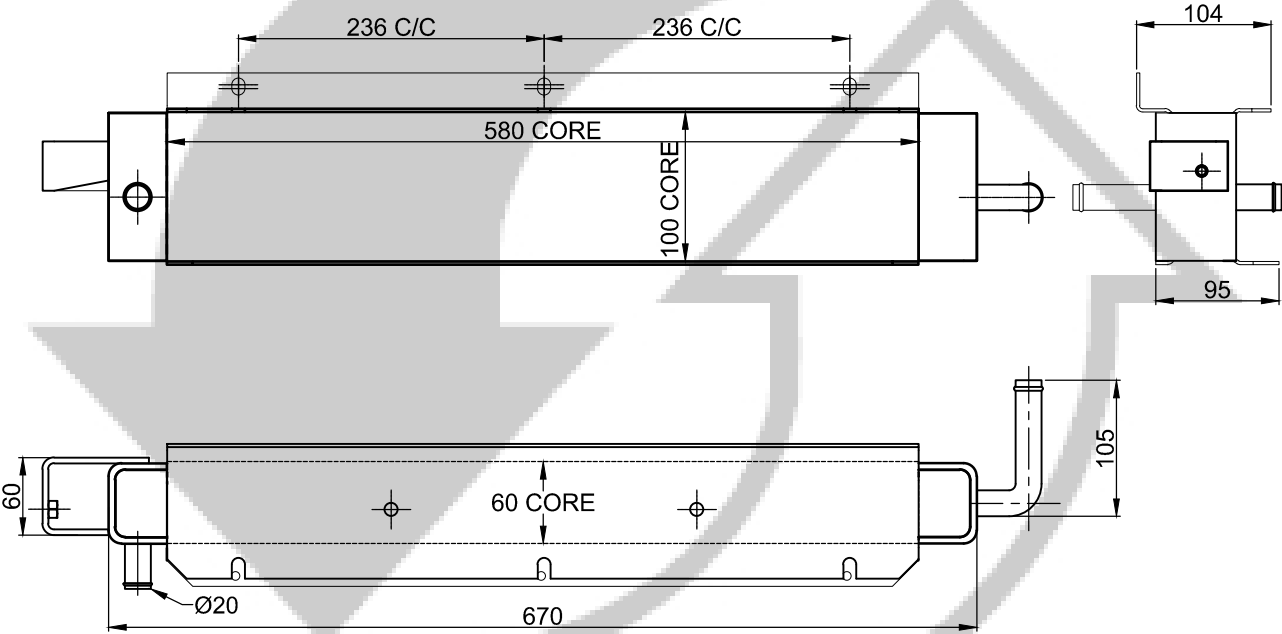

MODEL:JOHN DEERE

PART NUMBER:OIL580JOH1COM

OILCOOLER-LINDE

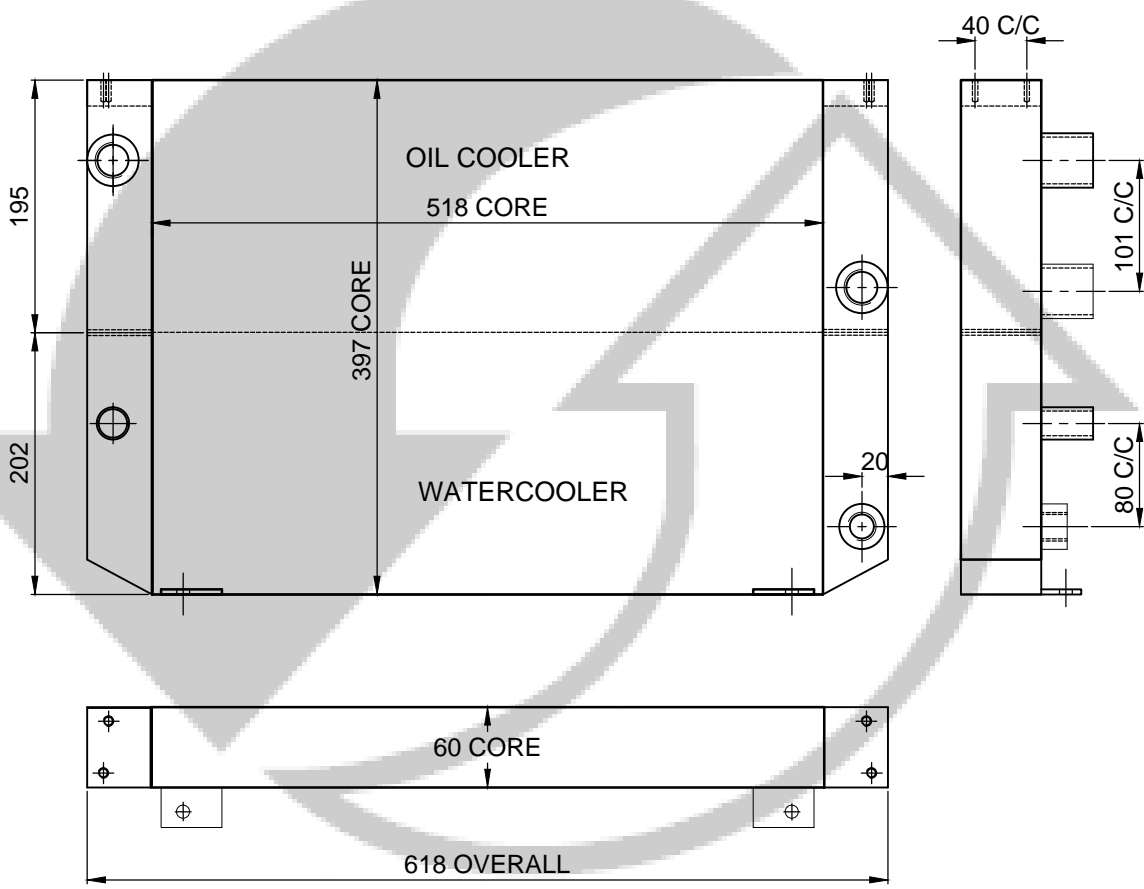

MODEL:LINDE

PART NUMBER:OIL502LIN1COM

OILCOOLER-MAGIRUS

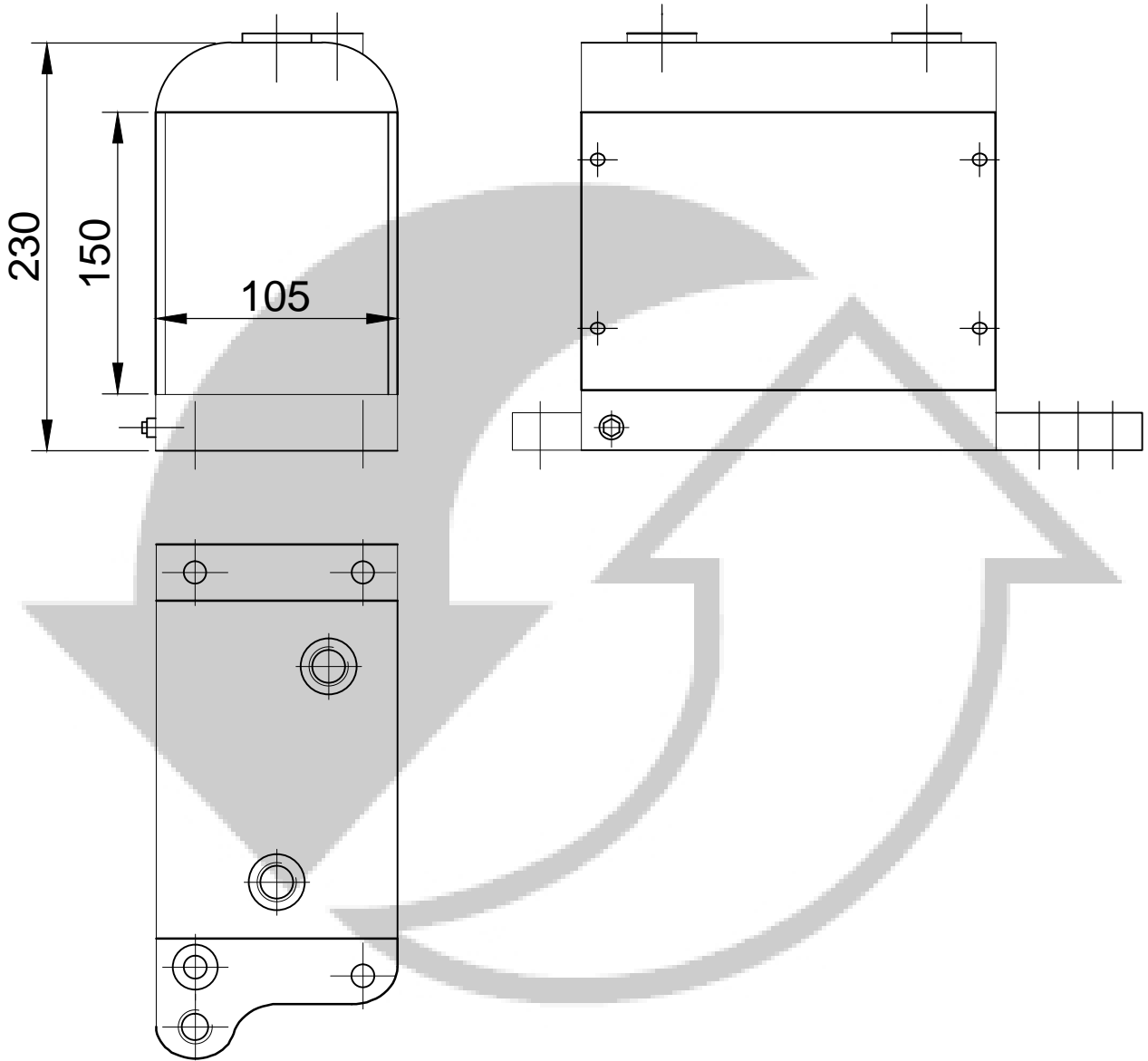

RECORE ONLY



MODEL:MAGIRUS DEUTZ

PART NUMBER:OIL150MAG1COM

OILCOOLER-MAGIRUS

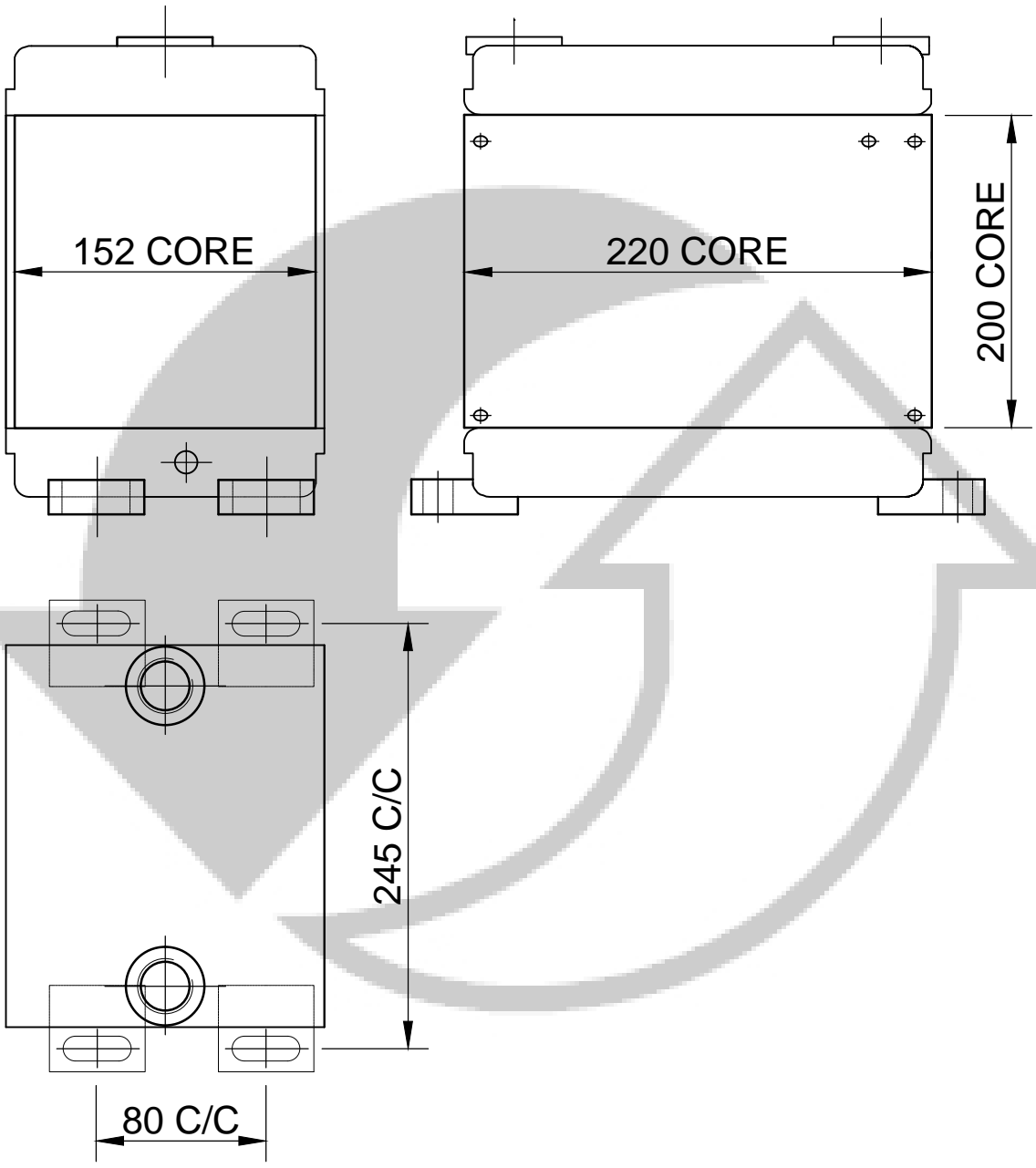

RECORE ONLY



MODEL:MAGIRUS DEUTZ

PART NUMBER:OIL180MAG1COM

OILCOOLER-MAGIRUS

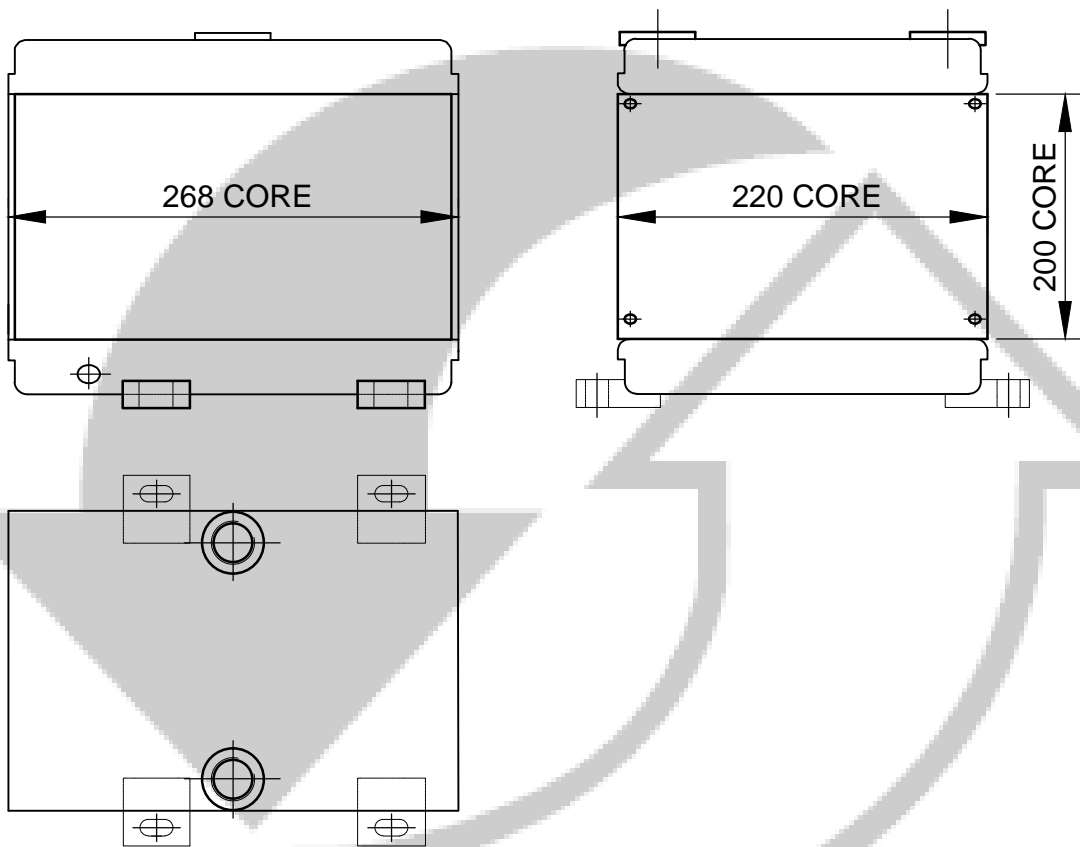

RECORE ONLY



MODEL:MAGIRUS DEUTZ

PART NUMBER:OIL180MAG2COM

OILCOOLER-MAGIRUS

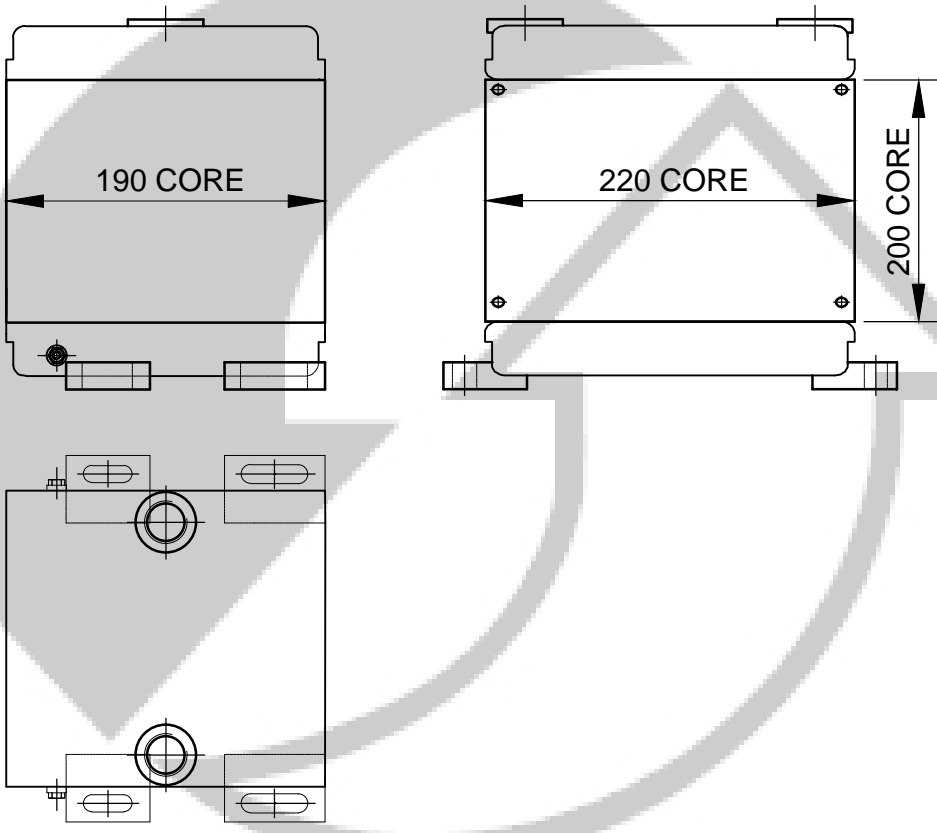

RECORE ONLY



MODEL:MAGIRUS DEUTZ

PART NUMBER:OIL180MAG3COM

OILCOOLER-MAGIRUS

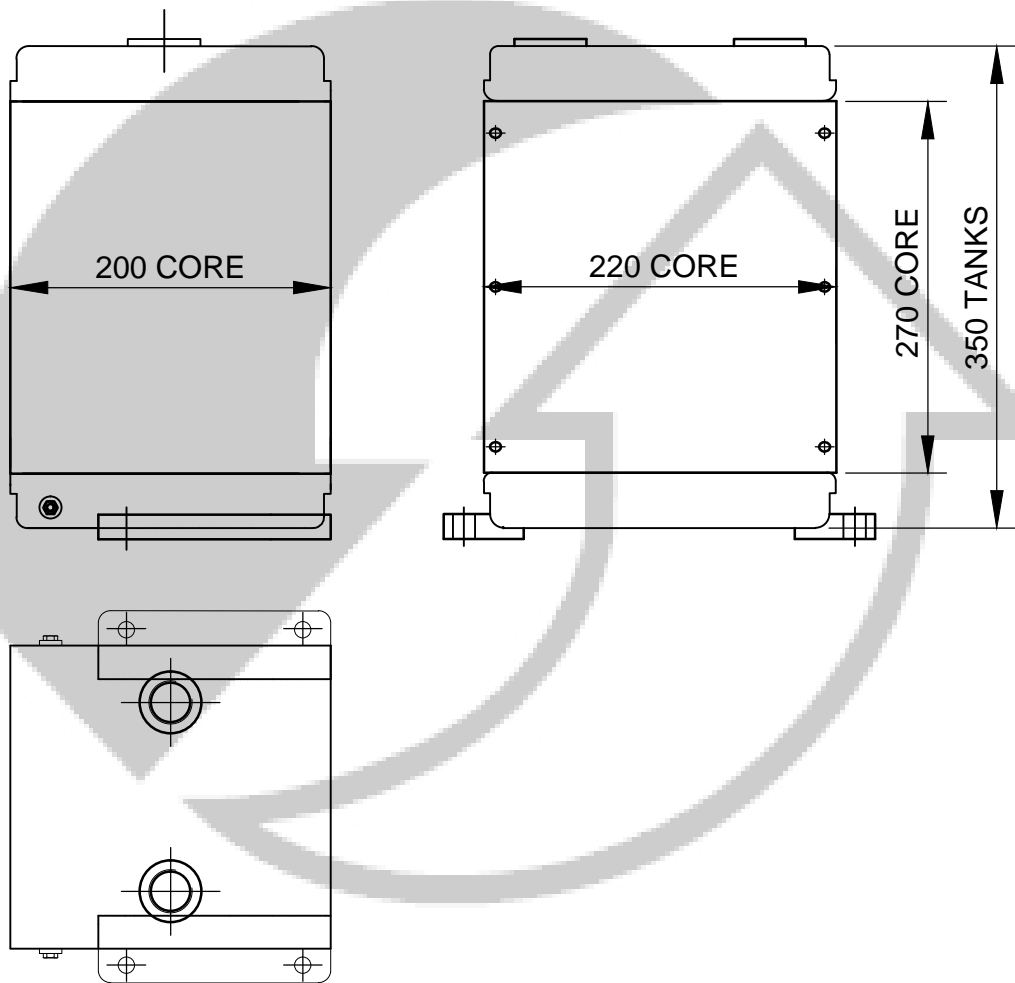

RECORE ONLY



MODEL:MAGIRUS DEUTZ

PART NUMBER:OIL270MAG1COM

OILCOOLER-MAGIRUS

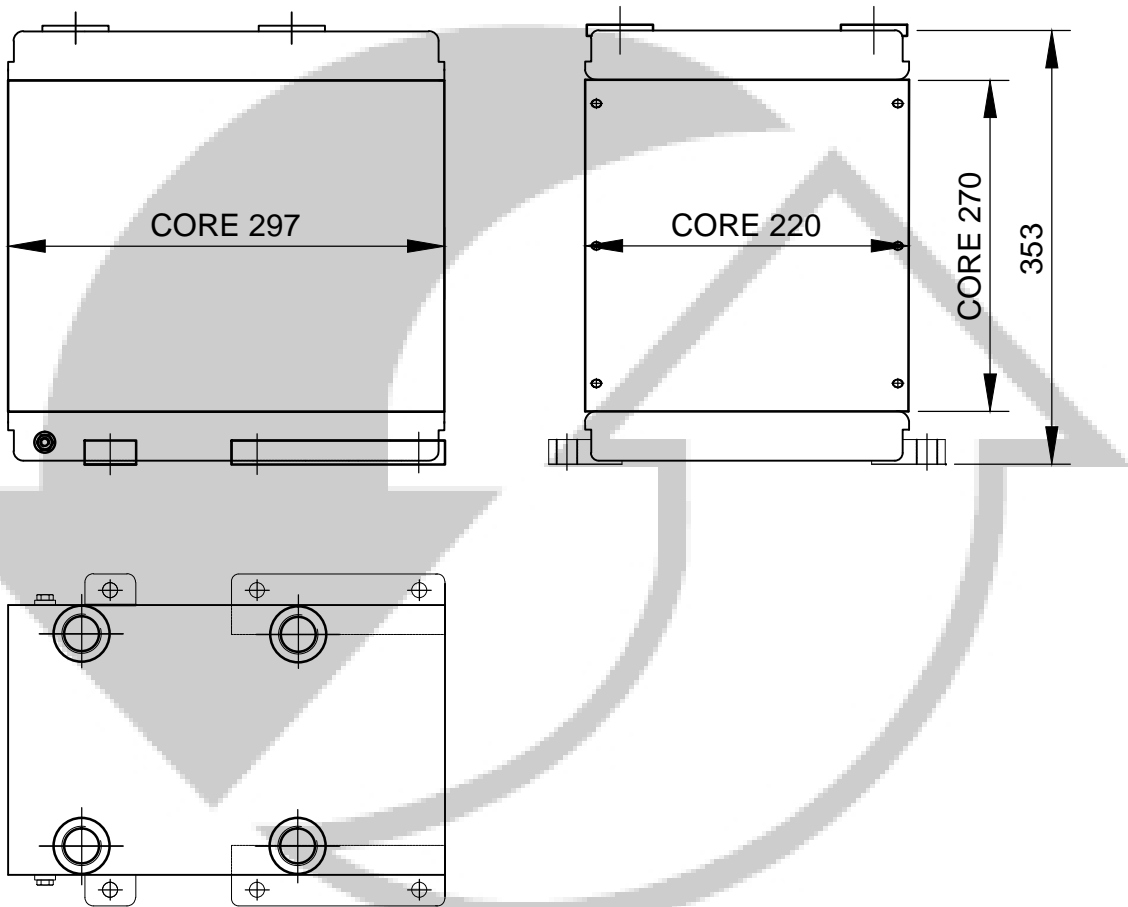

RECORE ONLY



MODEL:MAGIRUS DEUTZ

PART NUMBER:OIL270MAG2COM

OILCOOLER-MAGIRUS

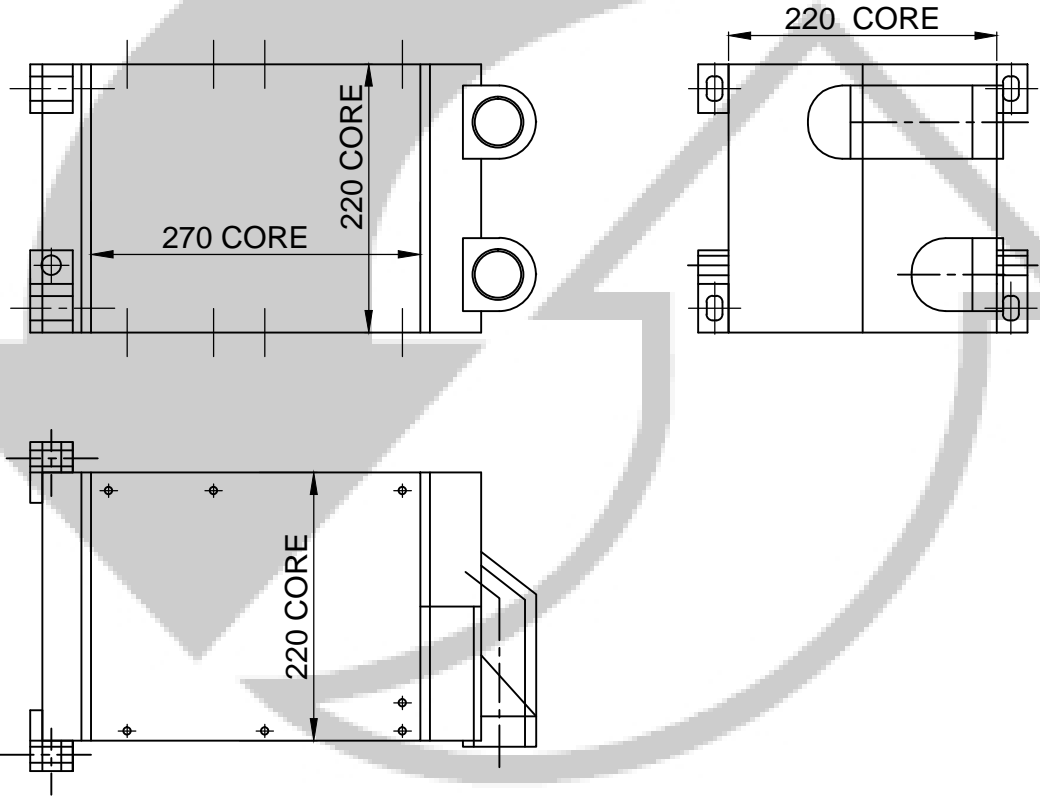

RECORE ONLY



MODEL:MAGIRUS DEUTZ

PART NUMBER:OIL270MAG3COM

OILCOOLER-MAN

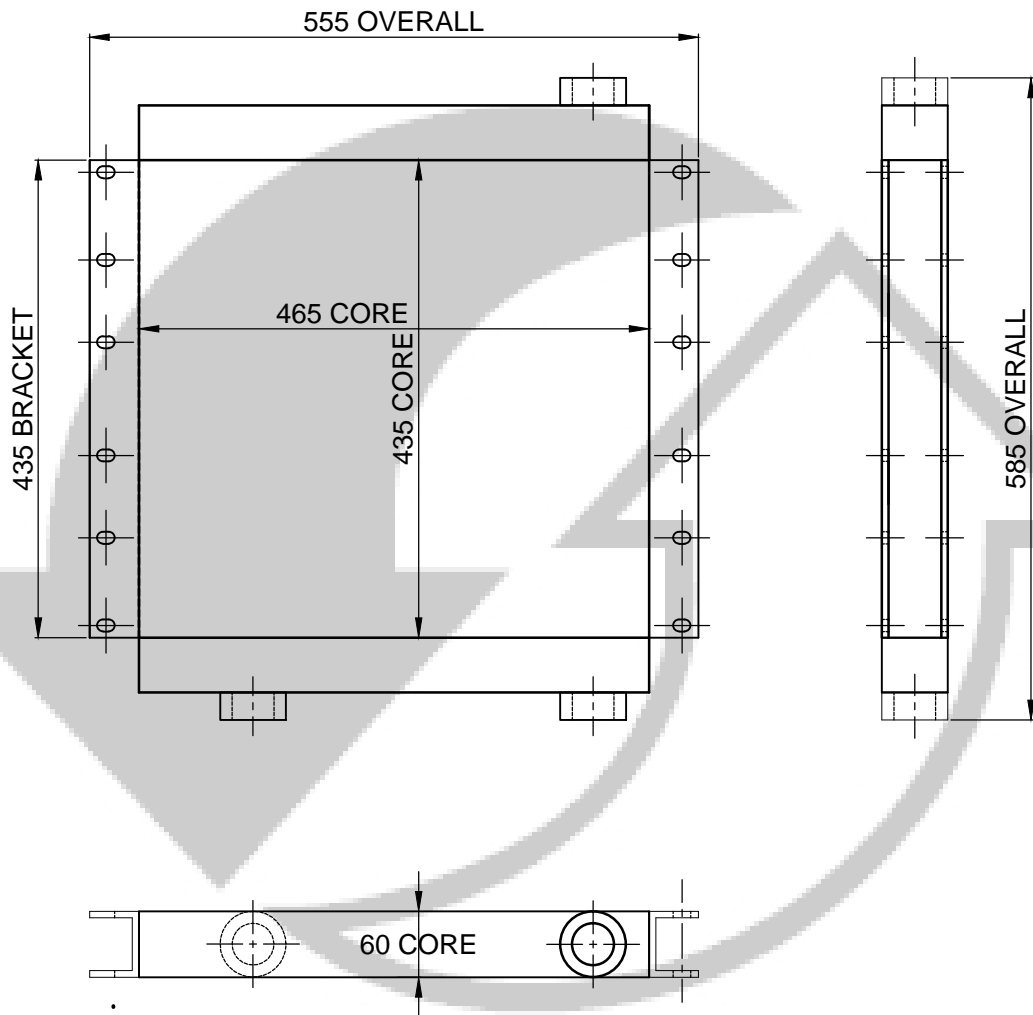

MODEL:MAN

PART NUMBER:OIL419MAN1COM

OILCOOLER-MAN

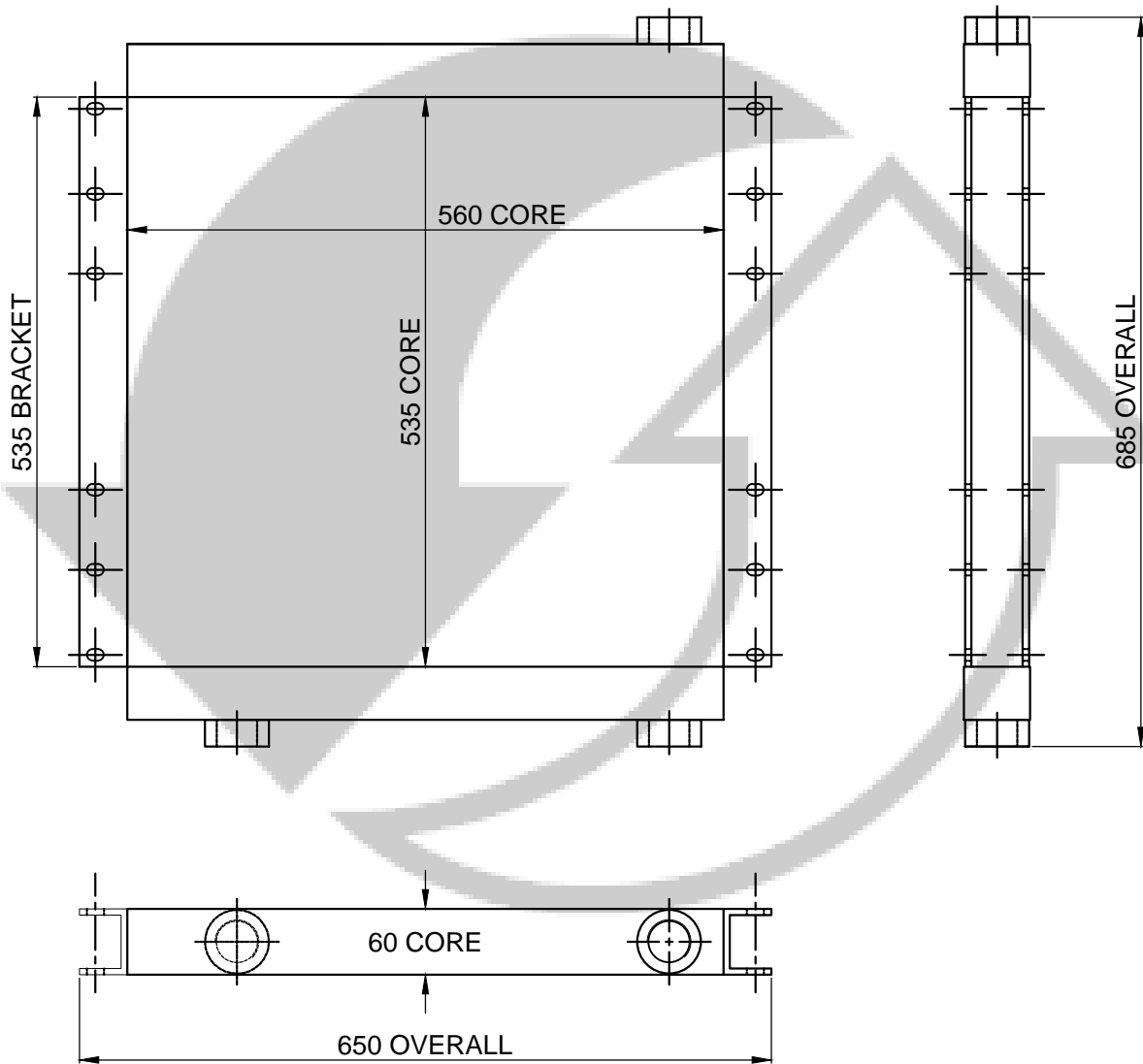

MODEL:MAN

PART NUMBER:OIL519MAN1COM

OILCOOLER-MERCEDES BENZ

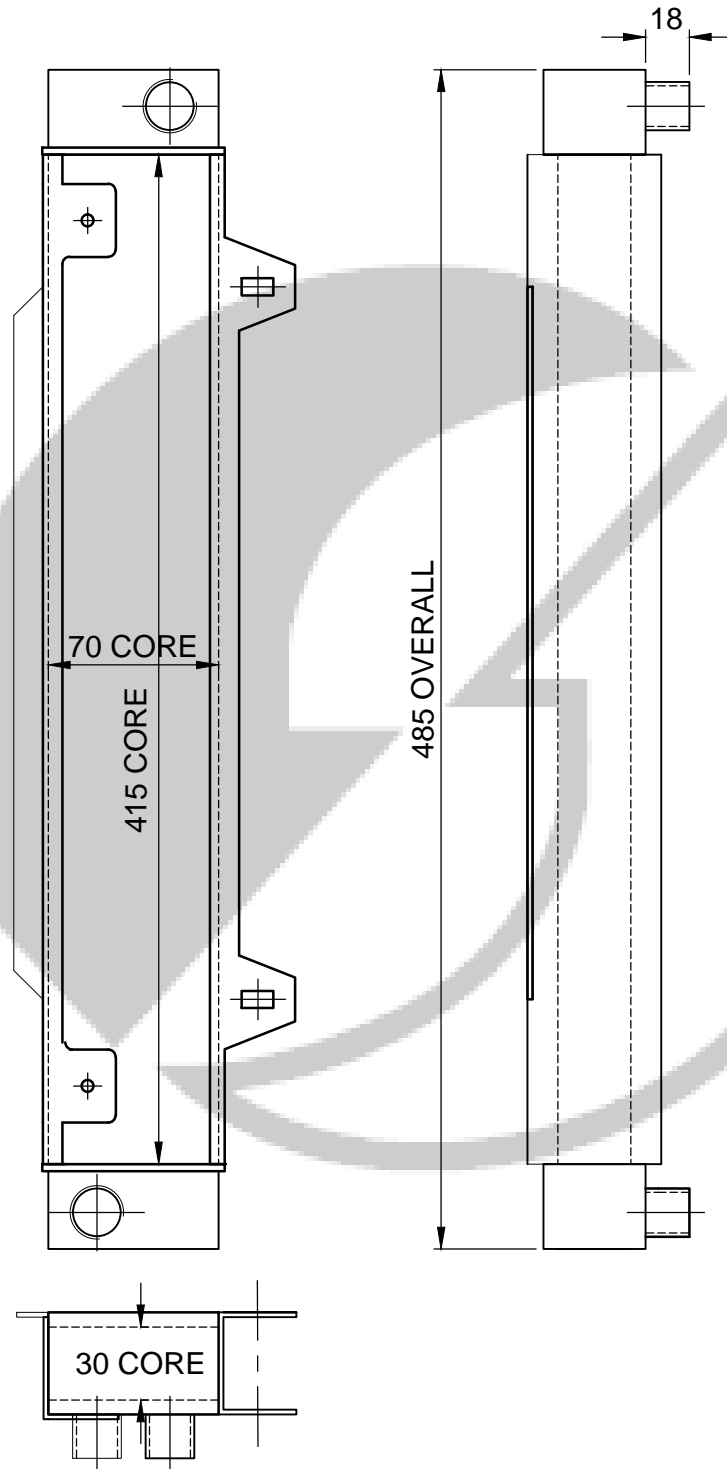

MODEL:MERCEDES BENZ

PART NUMBER:OIL415MER_1COM

OILCOOLER-MERCEDES BENZ

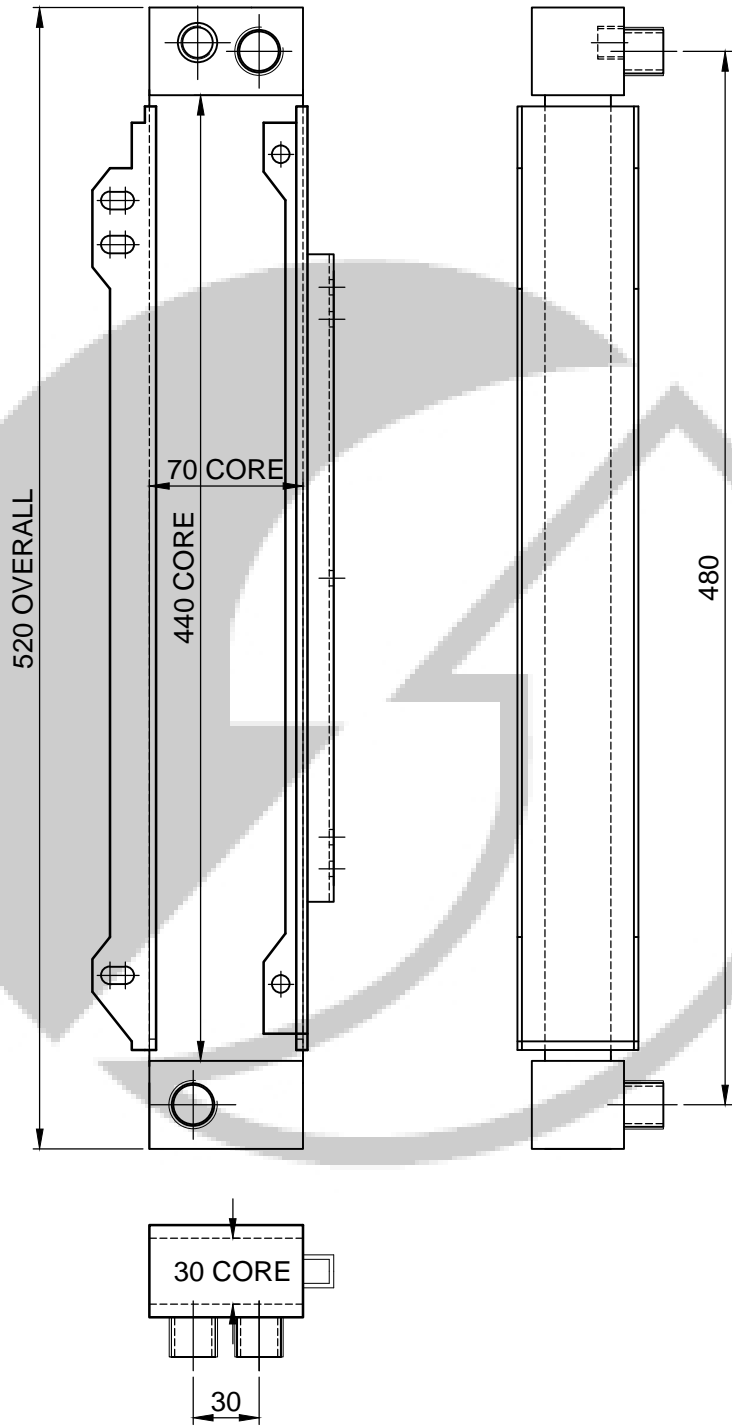

MODEL:MERCEDES BENZ

PART NUMBER:OIL440MER1COM

OILCOOLER-MERCEDES BENZ

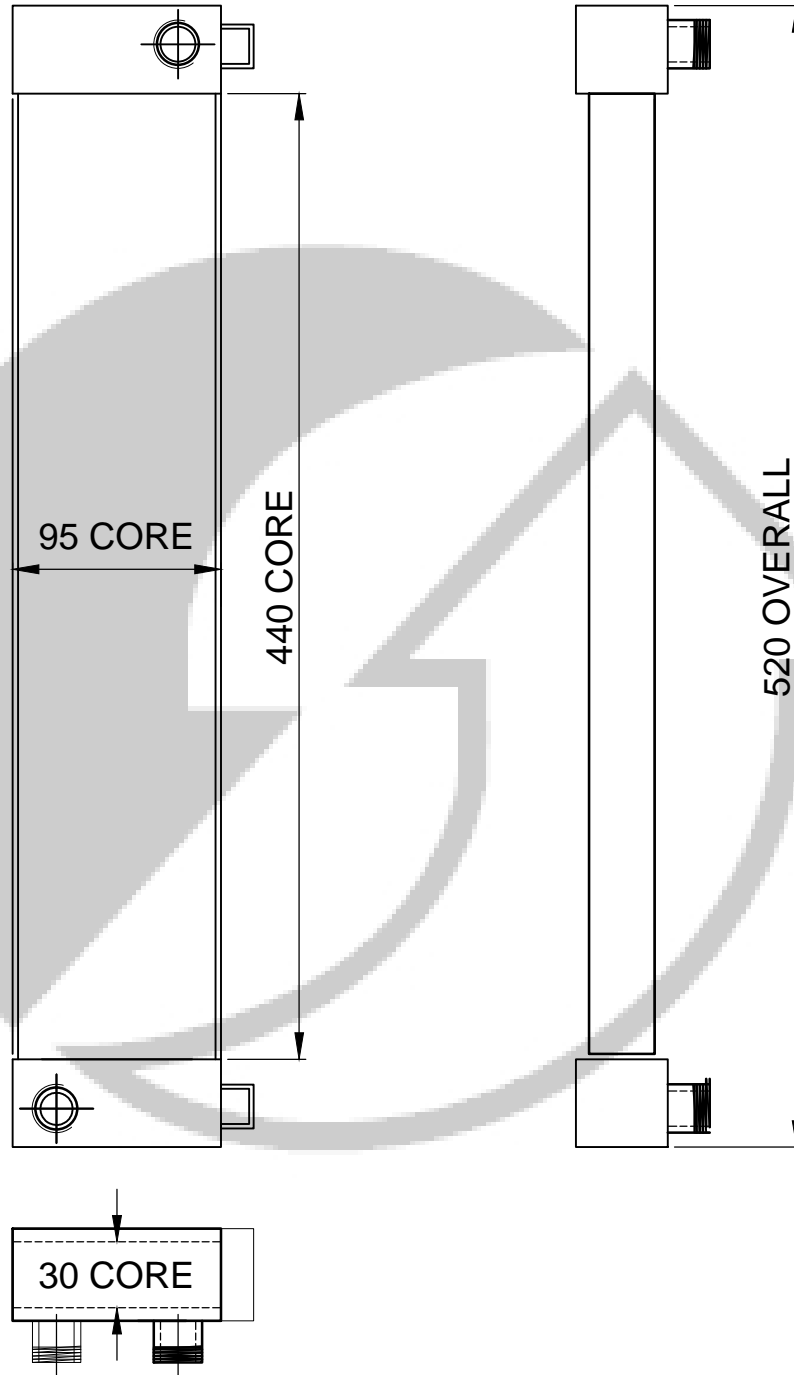

MODEL:MERCEDES BENZ

PART NUMBER:OIL440MER2COM

OILCOOLER-MERCEDES BENZ

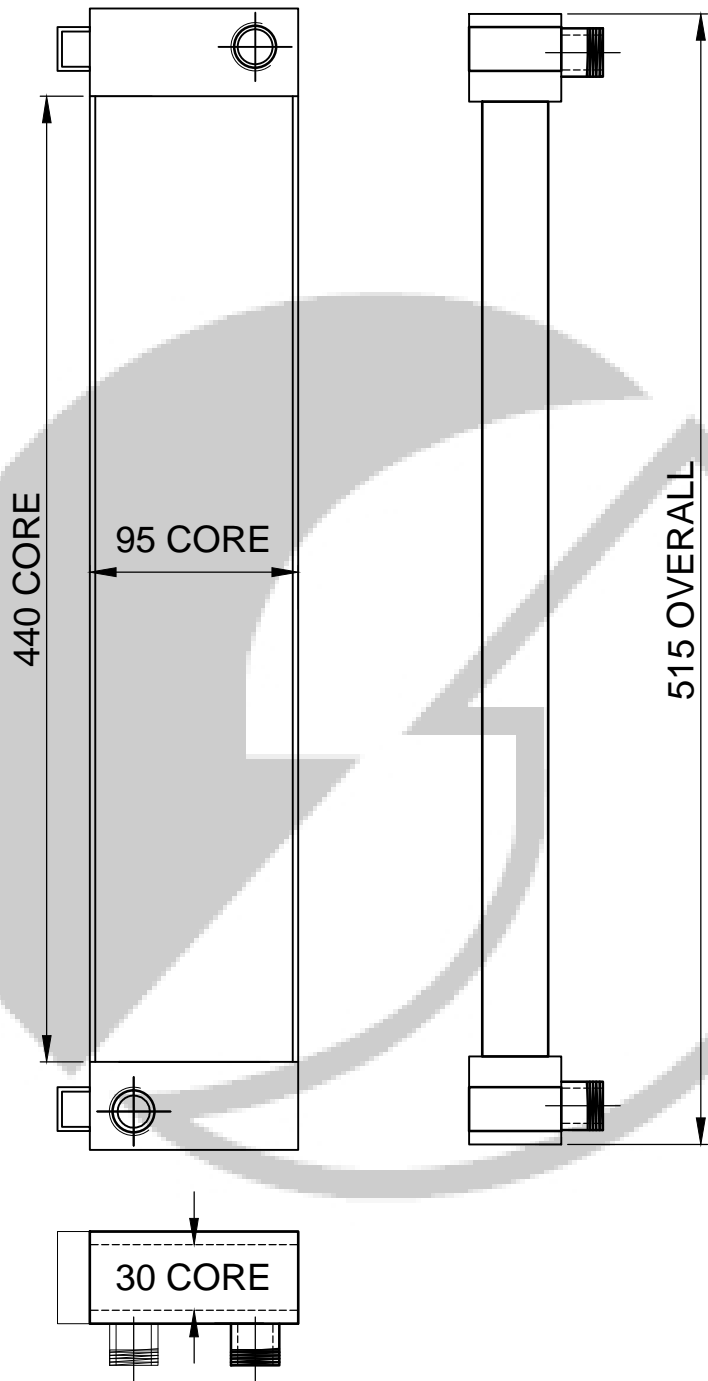

MODEL:MERCEDES BENZ

PART NUMBER:OIL440MER3COM

OILCOOLER-MERCEDES BENZ

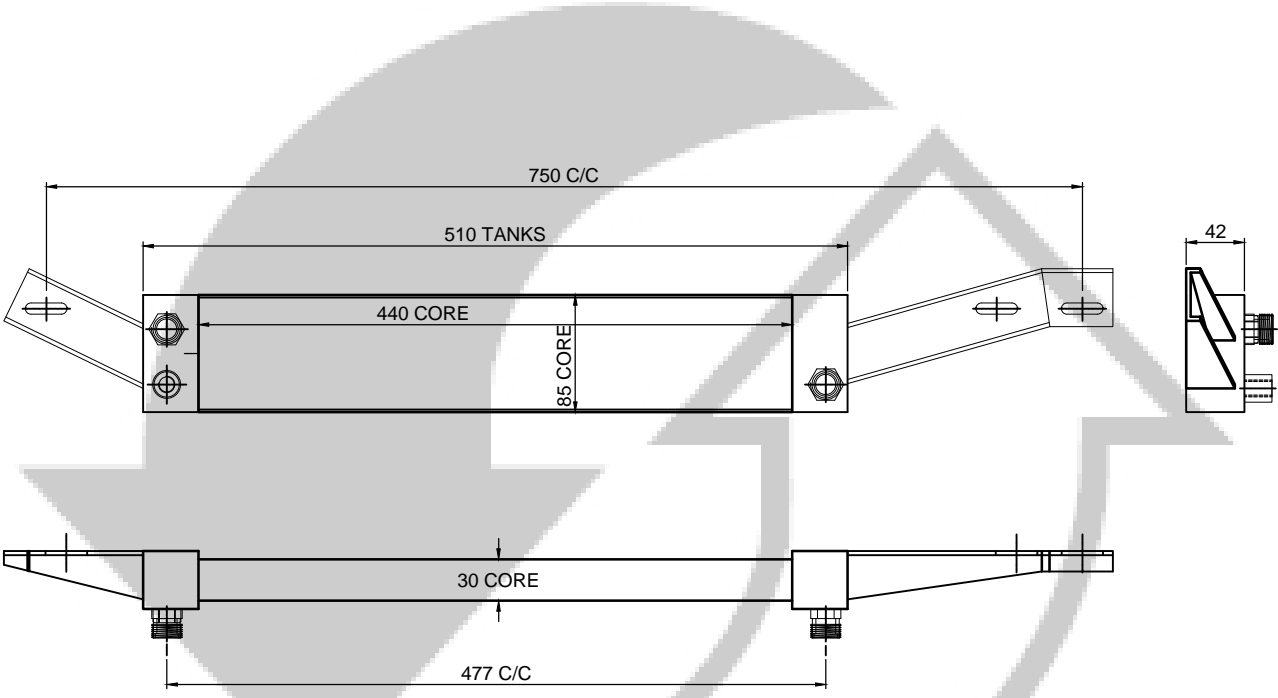

MODEL:MERCEDES BENZ

PART NUMBER:OIL440MER4COM

OILCOOLER-MERCEDES BENZ

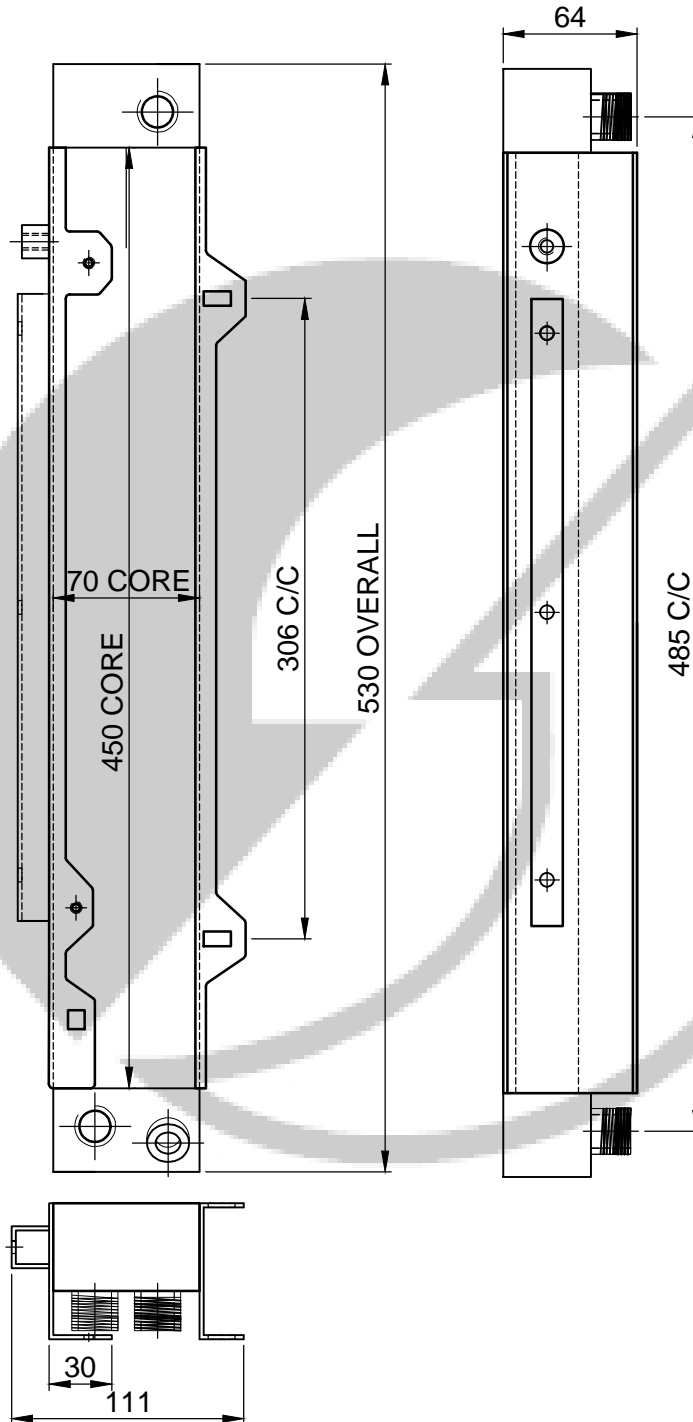

MODEL:MERCEDES BENZ

PART NUMBER:OIL450MER1COM

OILCOOLER-MERCEDES BENZ

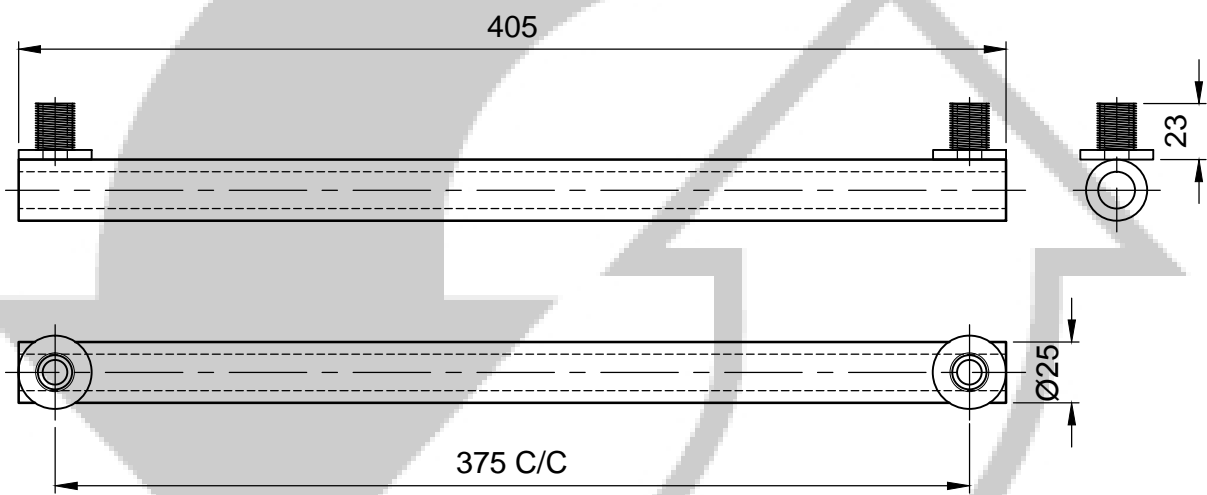

MODEL:MERCEDES BENZ

PART NUMBER:TMOC-DB405MER1COM

OILCOOLER-NISSAN

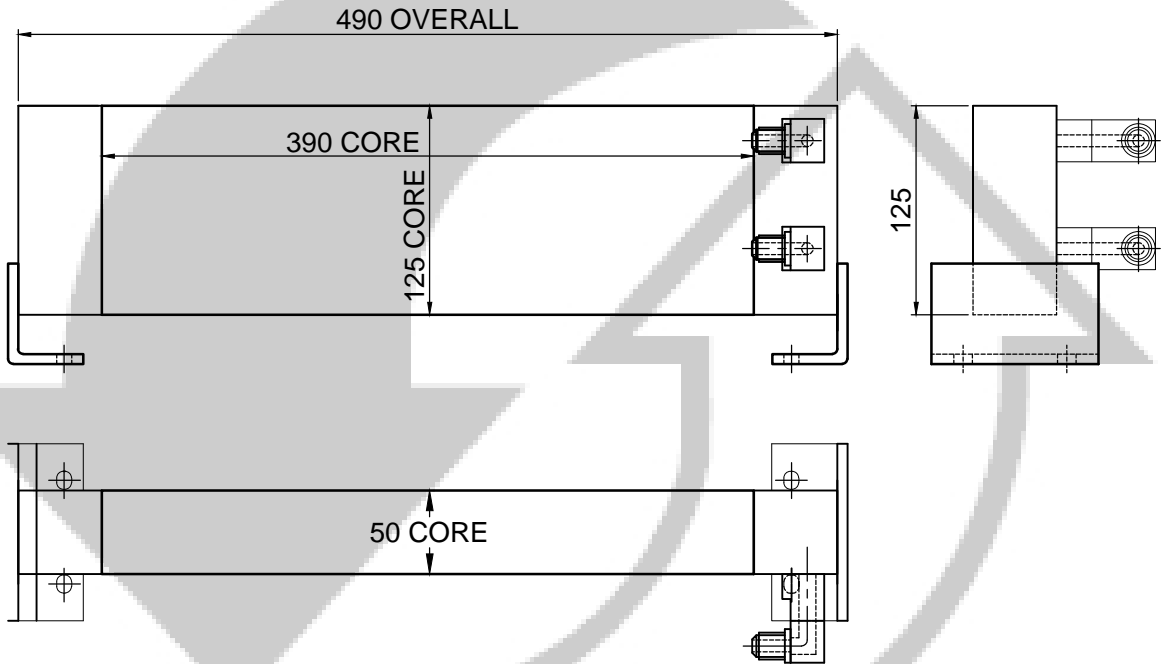

MODEL:NISSAN

PART NUMBER:OIL394NIS1COM

OILCOOLER-TUBE AND SHELL

Cape Heat Exchange is proud to announce the newly developed **SB-cooler** range. This is a replacement range for the popular Bowman heat exchangers. Similar to the Bowman heat exchangers it will be a tube and shell heat exchanger with either a copper or copper-nickel tube stack depending on whether the unit is used with fresh water or sea water. Different to the Bowman series this unit will have a full stainless steel 316 shell with end-caps and so move away from the pre-casted aluminium shells. This will also allow us to be more flexible to customer specifications as we aren't restricted by pre-casted shells and can manufacture to customer specific requirements. The stainless steel shell will increase the durability of the units and because the Bowman heat exchangers is a UK based product the lead time will be substantially less to produce locally.

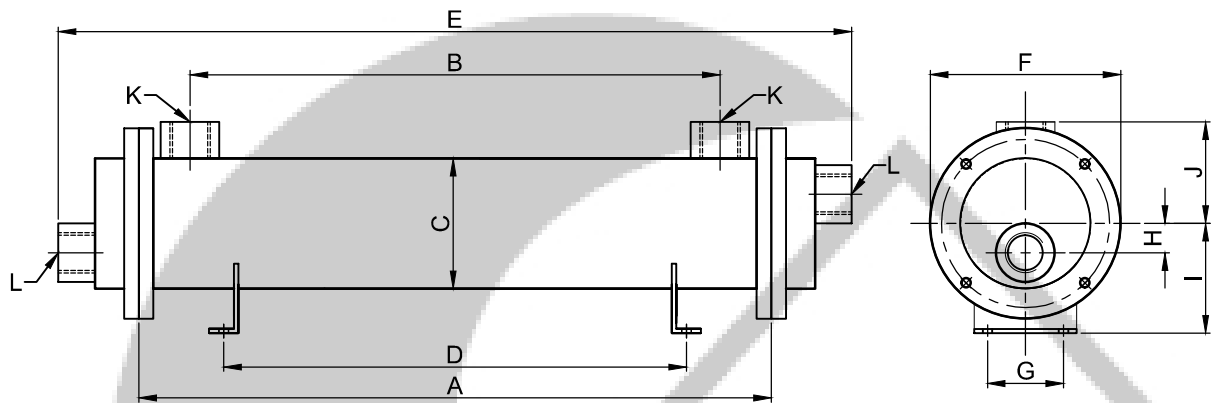

Model	# Tubes	A	B	C	D	E	F	G	H	I	J	K & L
83/210	65	210	140	89	104	320	130	52	20	71	69	3/4"
83/300	65	300	226	89	190	410	130	52	20	71	69	3/4"
83/400	65	400	324	89	288	510	130	52	20	71	69	3/4"
83/525	65	525	452	89	416	635	130	52	20	71	69	3/4"
108S/280	117	280	202	114	190	400	165	76	25	93	83	1"
108S/380	117	380	300	114	288	500	165	76	25	93	83	1"
108S/510	117	510	428	114	288	630	165	76	25	93	83	1"
108S/650	117	650	574	114	434	770	165	76	25	93	83	1"
108L/380	123	380	294	114	190	500	165	76	25	93	83	1 1/4"
108L/510	123	510	422	114	318	630	165	76	25	93	83	1 1/4"
108L/650	123	650	568	114	464	770	165	76	25	93	83	1 1/4"
108L/840	123	840	746	114	642	960	165	76	25	93	83	1 1/4"
135/370	197	370	272	141	108	510	215	120	38	117	108	1 1/2"
135/650	197	650	546	141	382	790	215	120	38	117	108	1 1/2"
135/830	197	830	724	141	560	970	215	120	38	117	108	1 1/2"
135/1030	197	1030	926	141	762	1170	215	120	38	117	108	1 1/2"



MODEL: TUBE AND SHELL/SB RANGE

PART NUMBER: SB83 TO SB135

OILCOOLER-SUZUKI

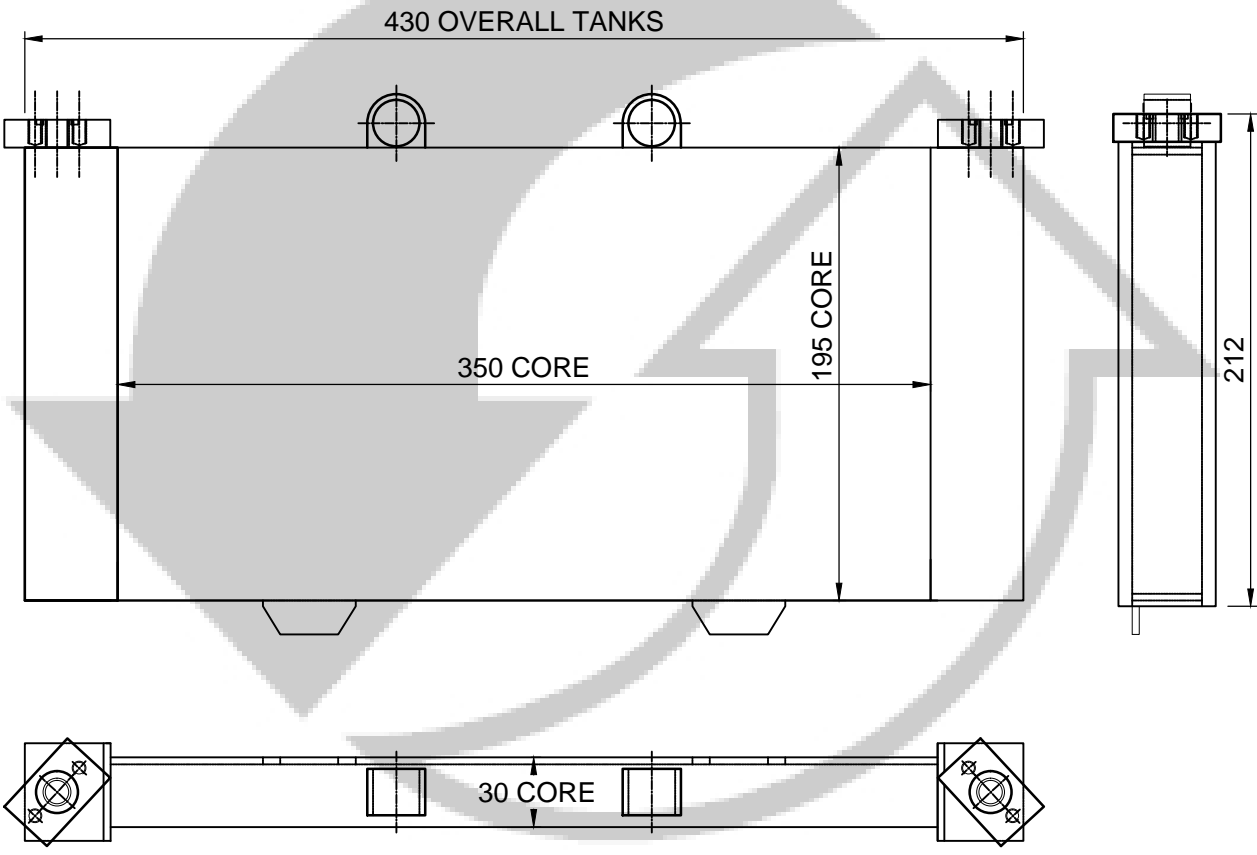

MODEL:SUZUKI

PART NUMBER:OIL356SUZ1COM

OILCOOLER-SUZUKI

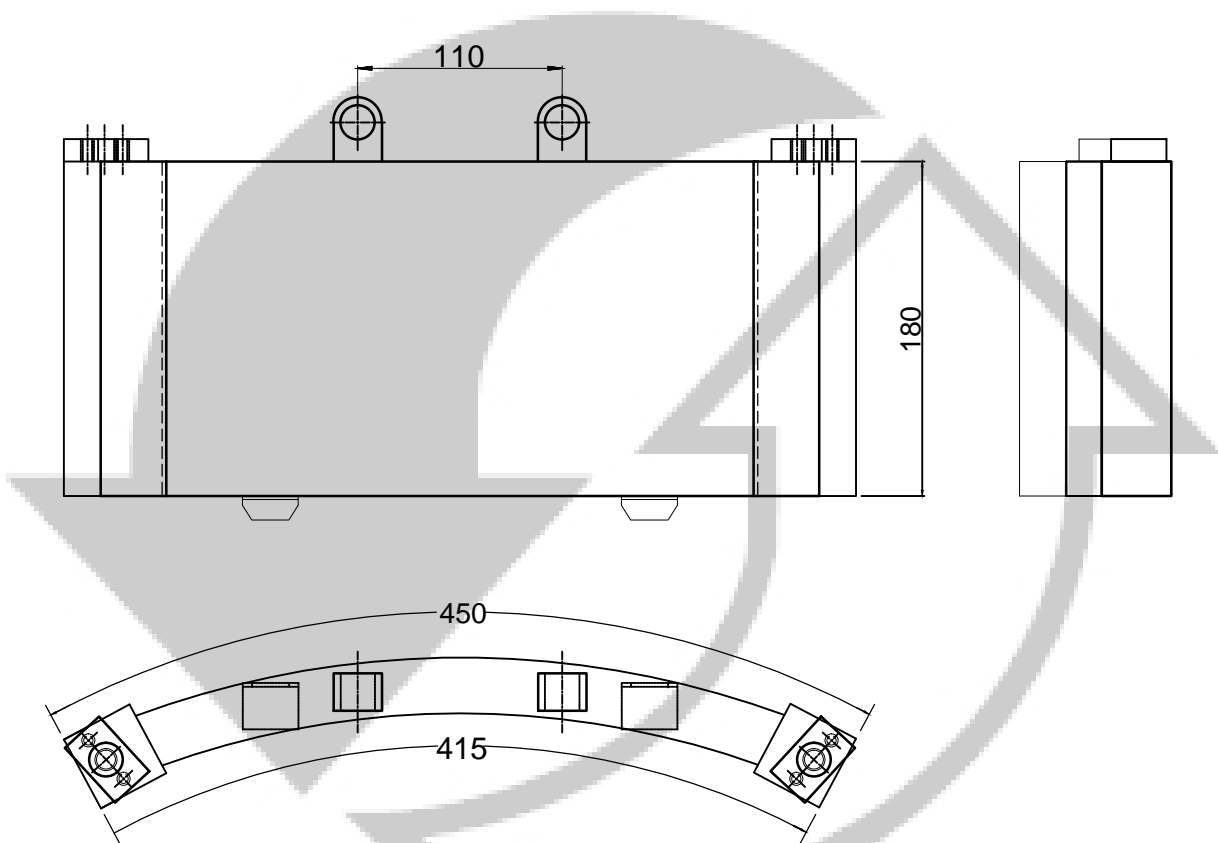

MODEL:SUZUKI

PART NUMBER:OIL368SUZ1COM

OILCOOLER-SCANIA

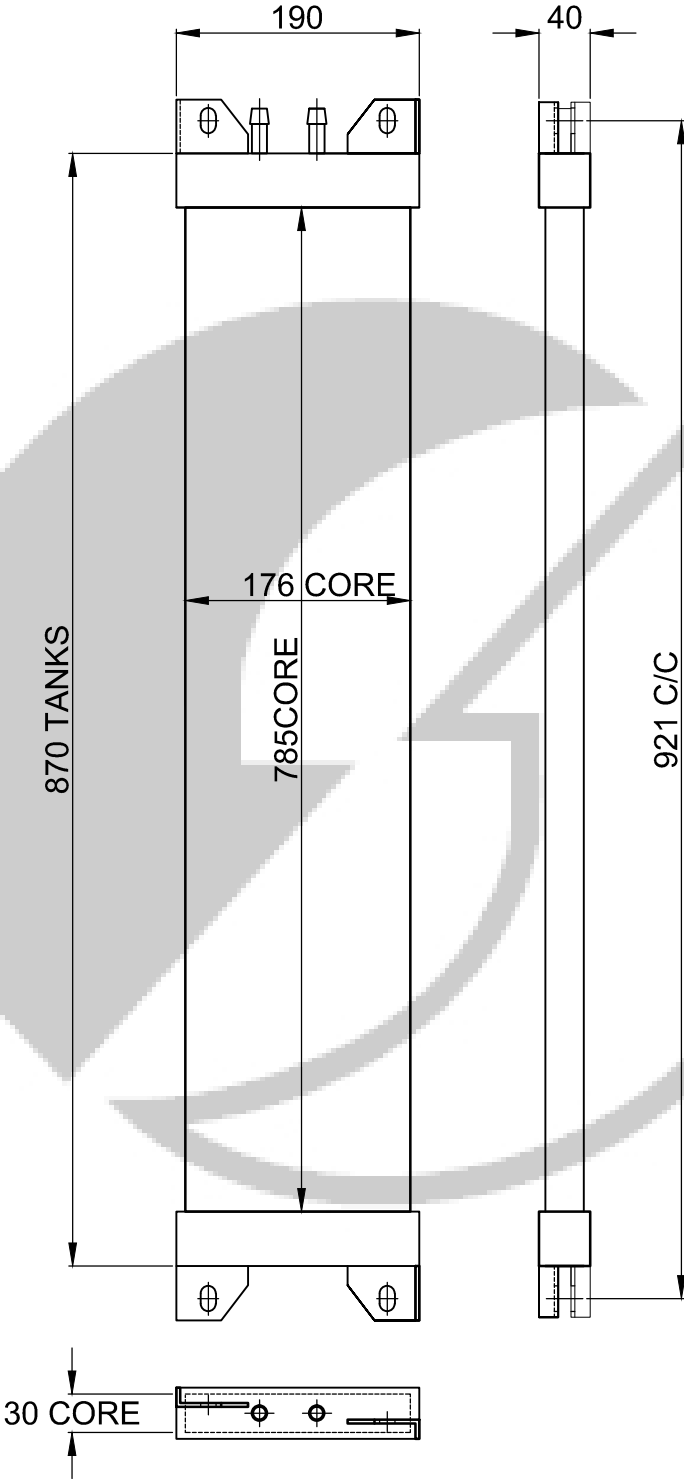

MODEL:SCANIA

PART NUMBER:OIL785SCA1COM

OILCOOLER-TOYOTA

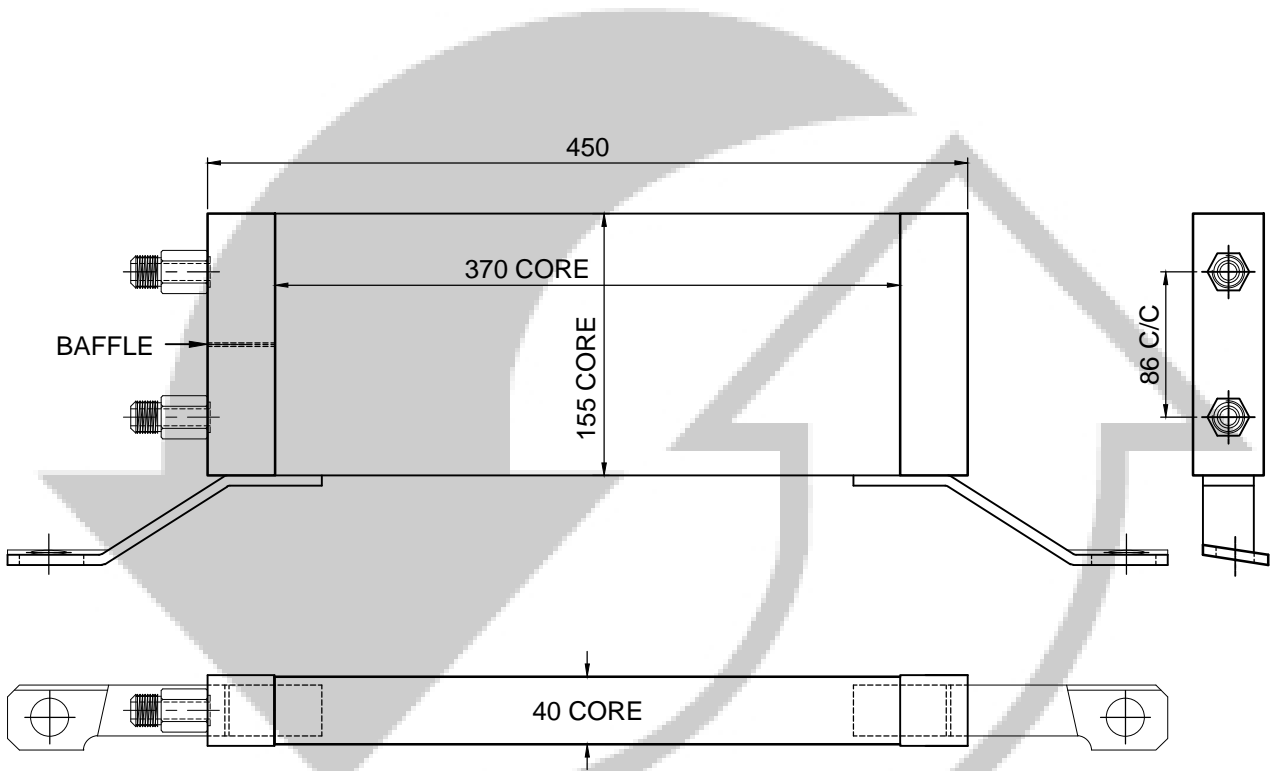

MODEL:TOYOTA

PART NUMBER:OIL400TOY1COM

OILCOOLER-ZIP COOLER

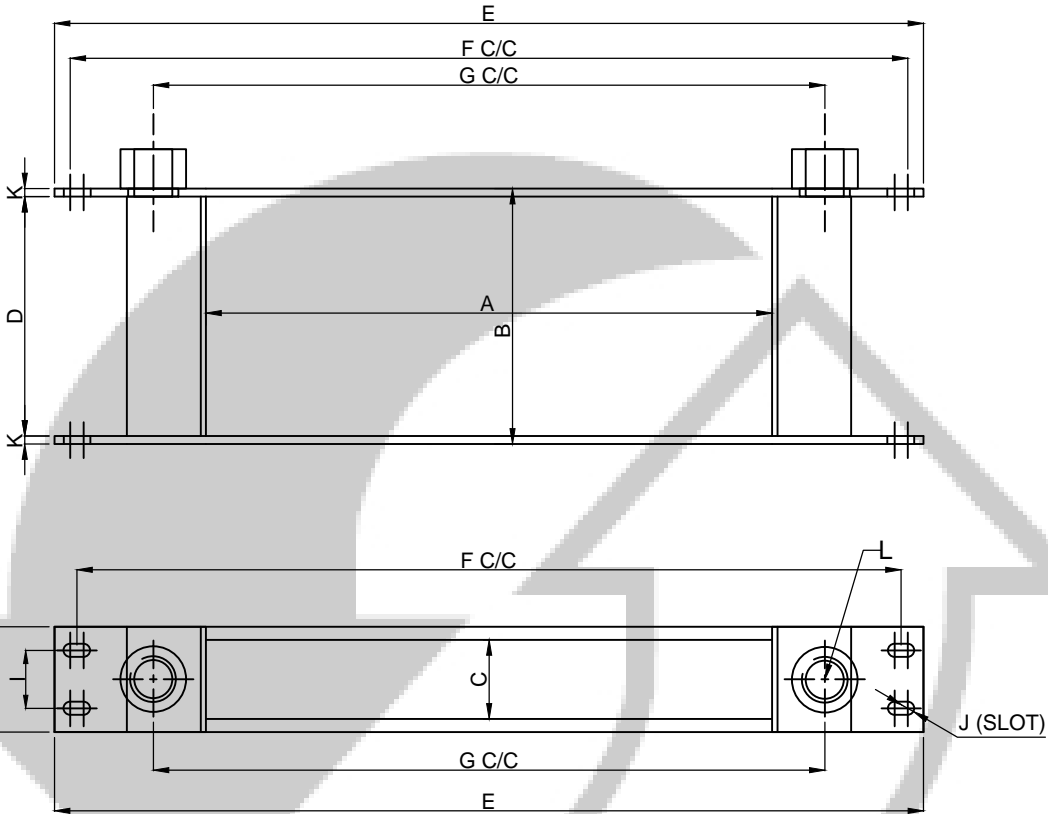

MODEL	A	B	C	D	E	F	G	H	I	J (SLOT)	K	L
ZIP3	215	60	30	54	330	312	248	42	22	Ø5 X 10	3	3/8NPT X 18TPI
ZIP5	215	80	30	74	330	312	248	42	22	Ø5 X 10	3	3/8NPT X 18TPI
ZIP7	215	96	30	90	330	312	248	42	22	Ø5 X 10	3	3/8NPT X 18TPI
ZIP9	215	125	30	119	330	312	248	42	22	Ø5 X 10	3	3/8NPT X 18TPI
ZIP11	215	150	30	144	330	312	248	42	22	Ø5 X 10	3	3/8NPT X 18TPI
ZIP13	215	167	30	161	330	312	248	42	22	Ø5 X 10	3	3/8NPT X 18TPI
ZIP15	215	200	30	194	330	312	248	42	22	Ø5 X 10	3	3/8NPT X 18TPI



MODEL:ZIP COOLER

PART NUMBER:

TRANSMISSION OILCOOLER - FORD

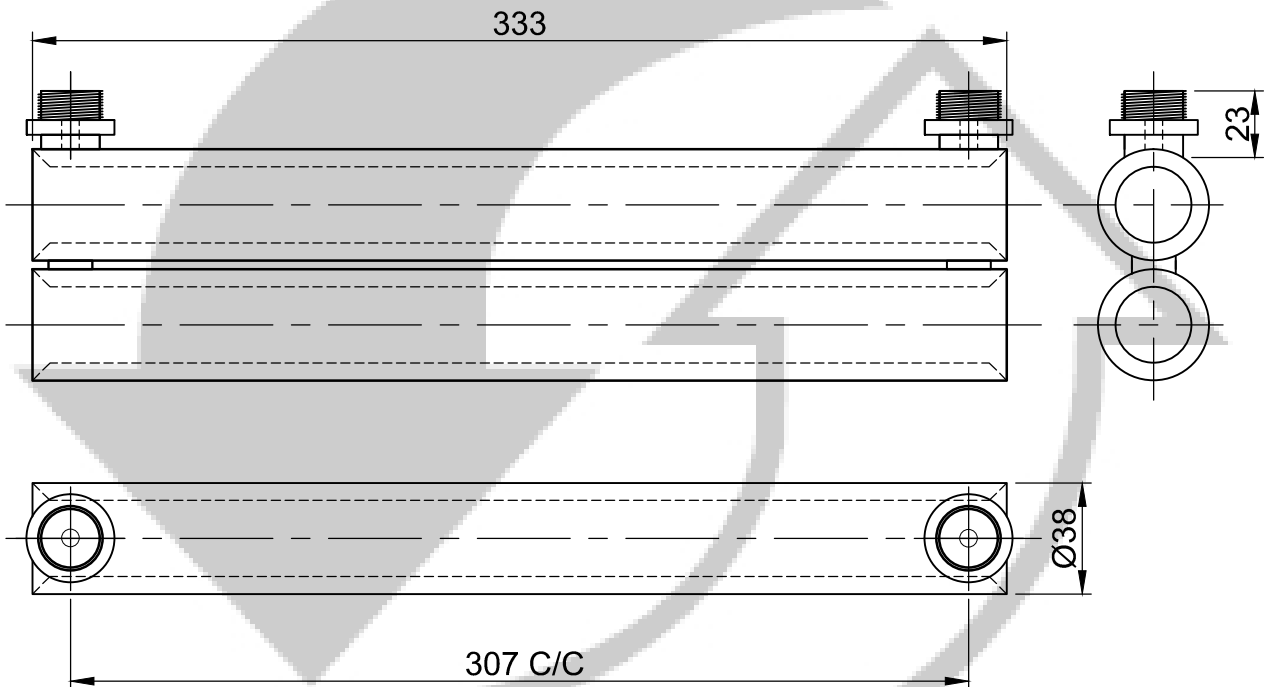

MODEL:FORD

PART NUMBER:TMOC333FOR1

TRANSMISSION OILCOOLER-HYSTER

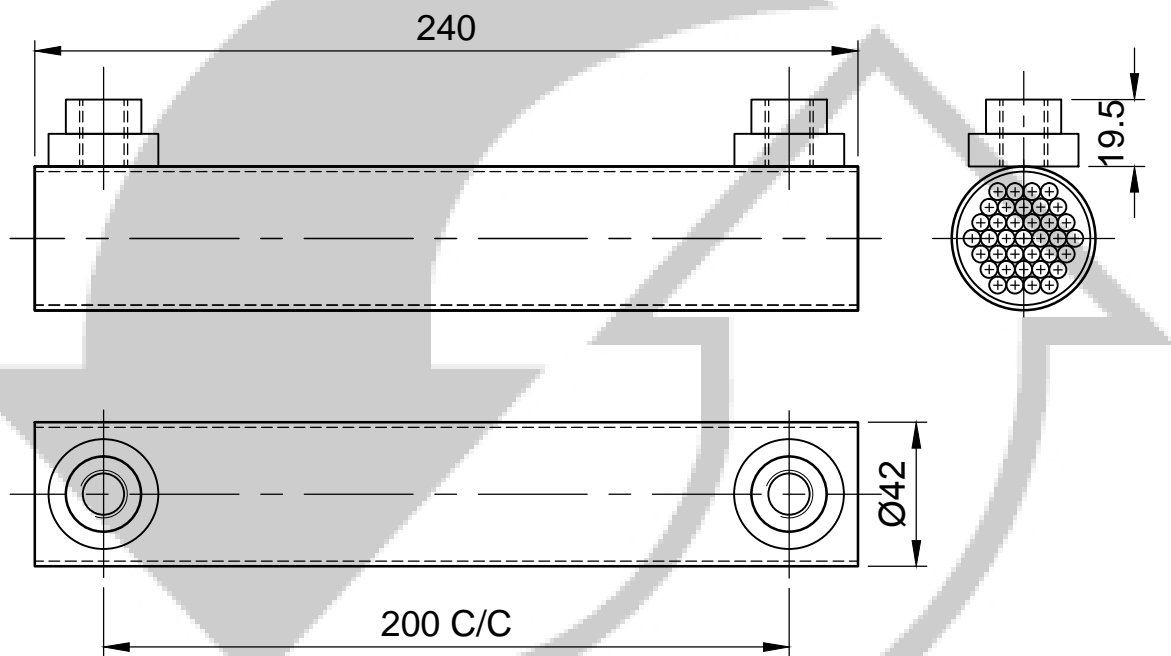

MODEL:HYSTER

PART NUMBER:TMOC240HYS1COM

TRANSMISSION OILCOOLER-HYSTER

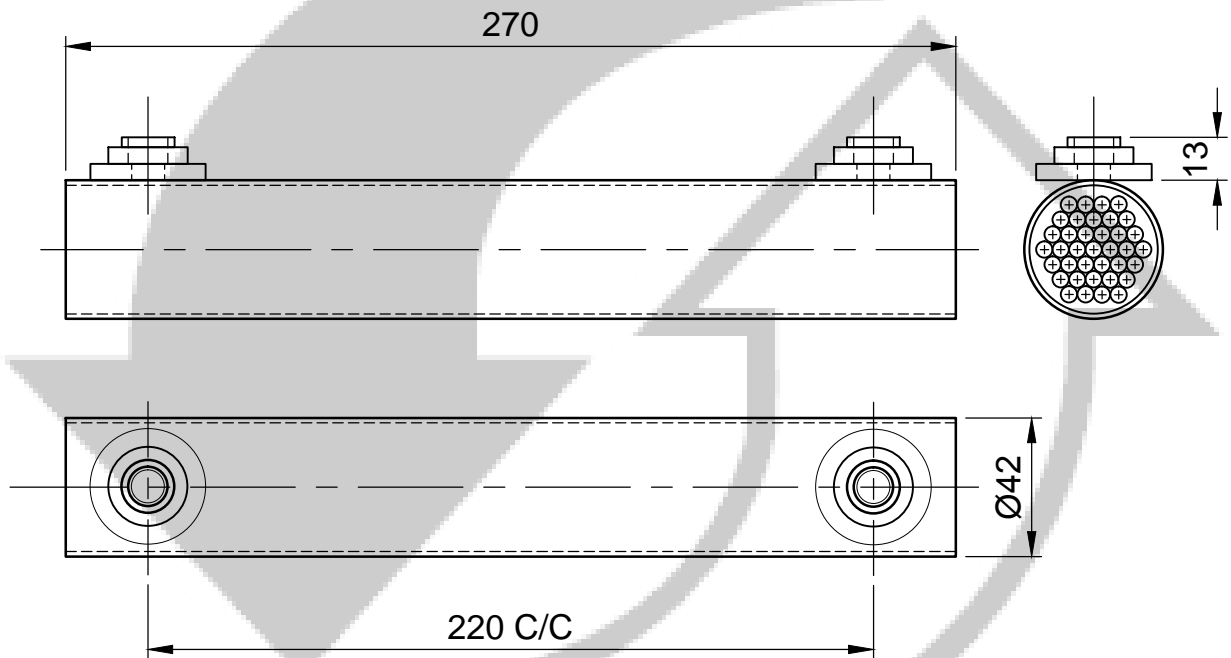

MODEL:HYSTER

PART NUMBER:TMOC270HYS1COM

TRANSMISSION OILCOOLER-HYSTER

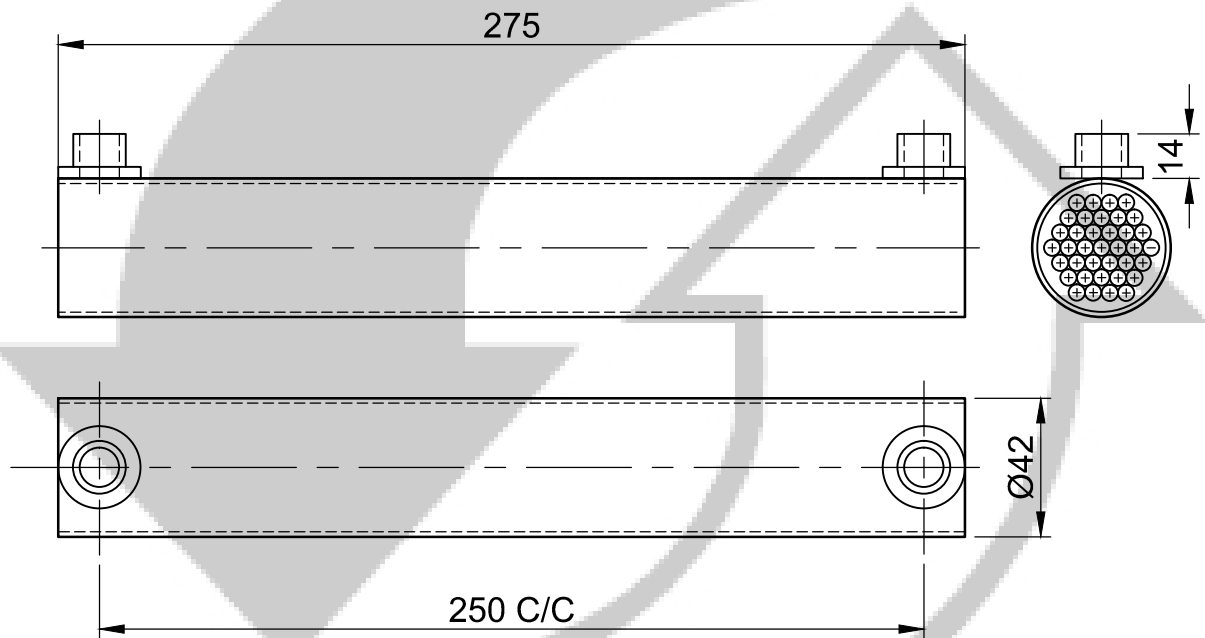

MODEL:HYSTER

PART NUMBER:TMOC275HYS1COM

TRANSMISSION OILCOOLER-HYSTER

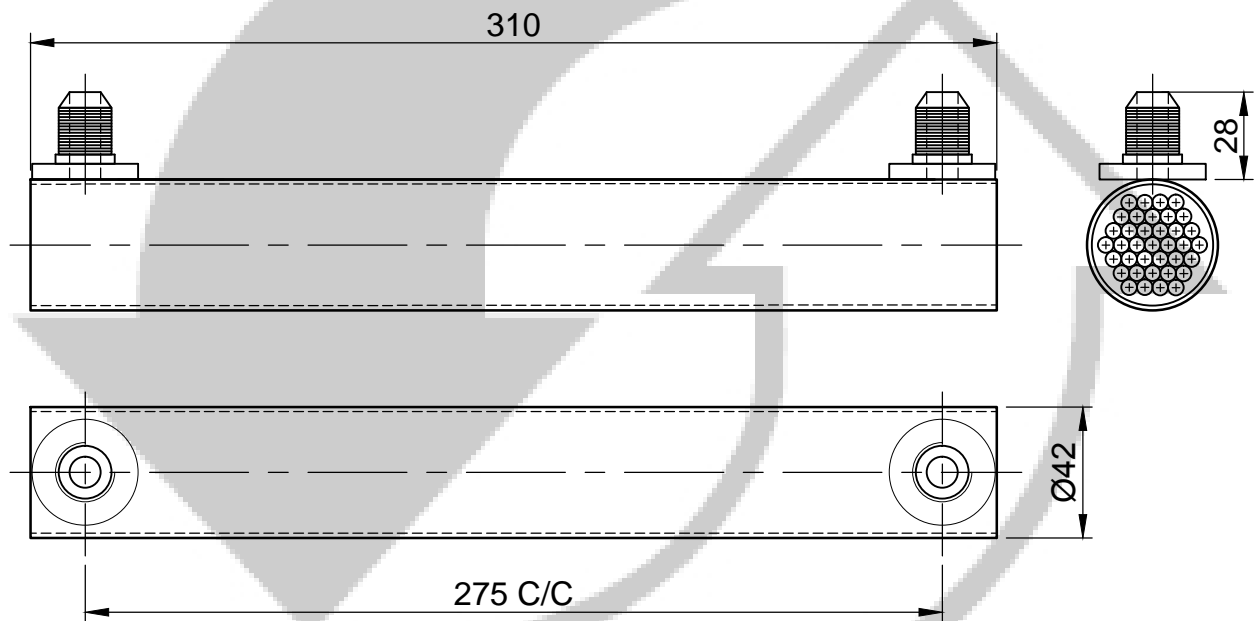

MODEL:HYSTER

PART NUMBER:TMOC310HYS1COM

TRANSMISSION OILCOOLER-HYSTER

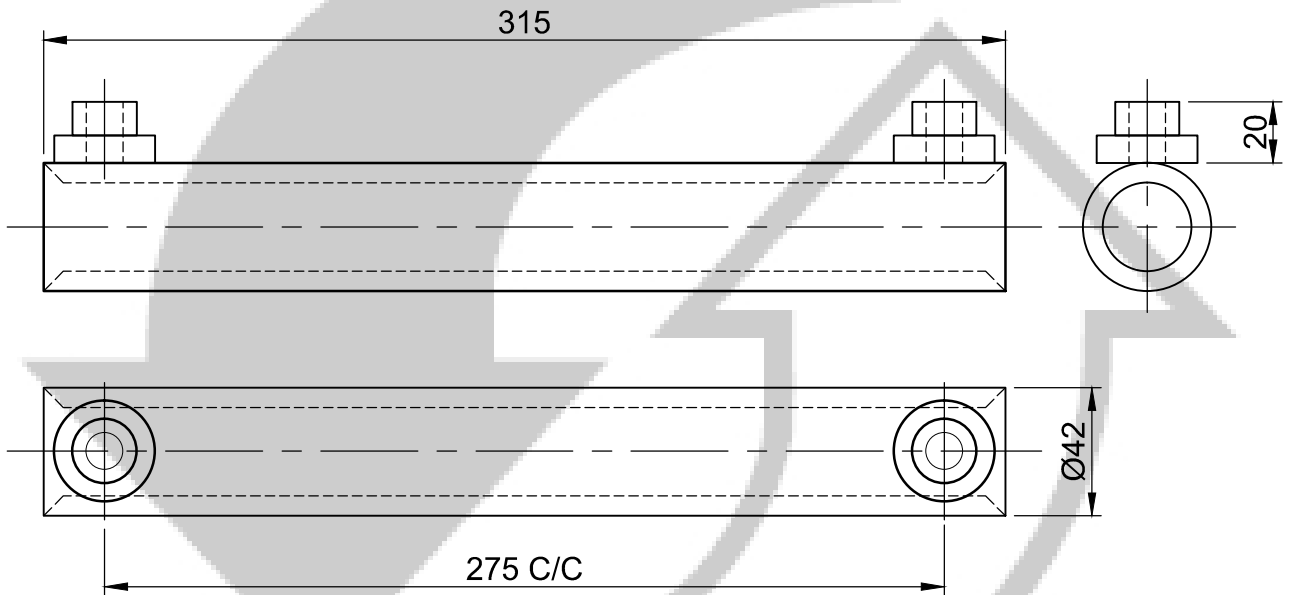

MODEL:HYSTER

PART NUMBER:TMOC-DB315HYS1COM

TRANSMISSION OILCOOLER-HYSTER

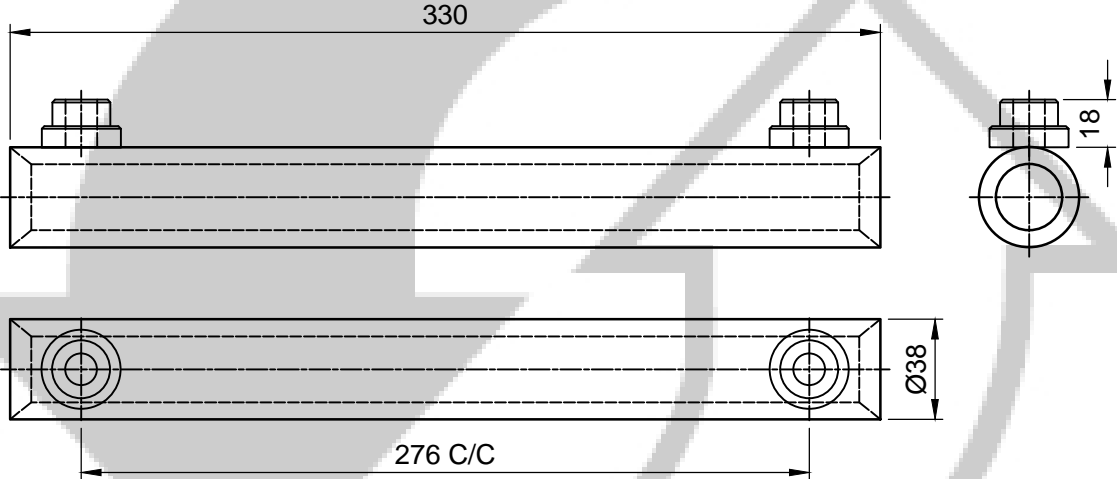

MODEL:HYSTER

PART NUMBER:TMOC330HYS1COM

TRANSMISSION OILCOOLER-HYSTER

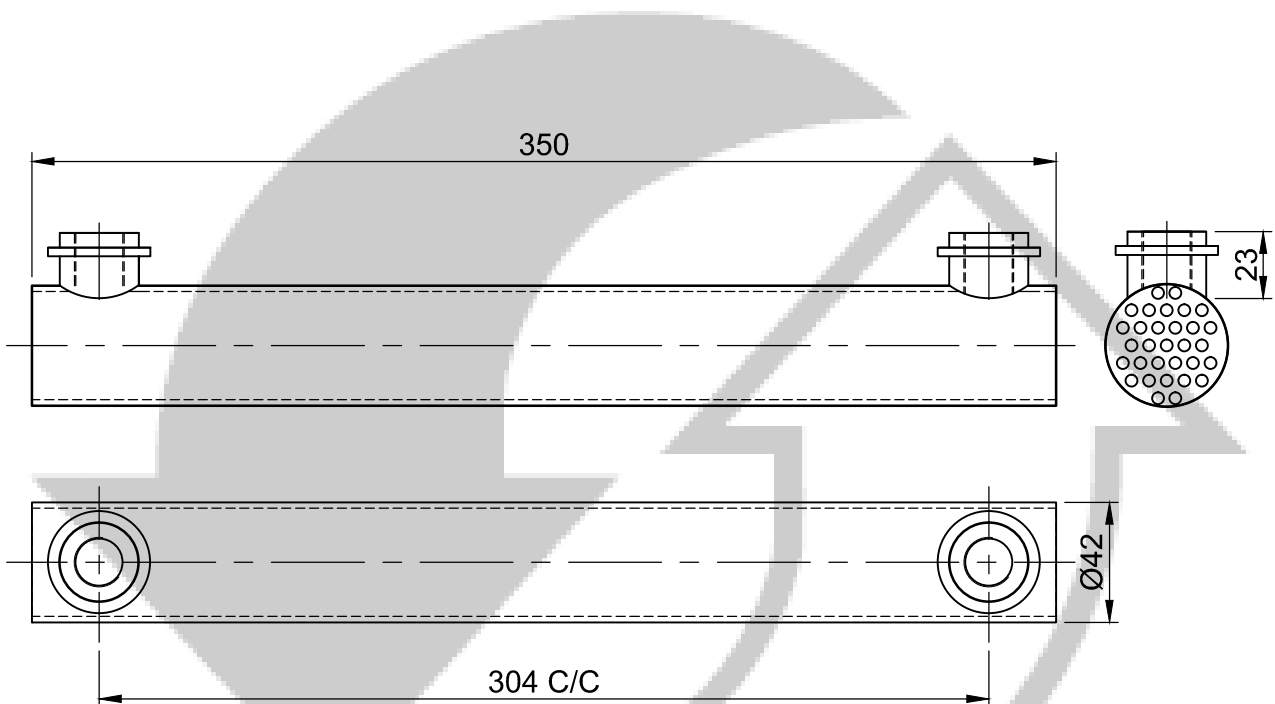

MODEL:HYSTER

PART NUMBER:TMOC350HYS1COM

TRANSMISSION OILCOOLER-HYSTER

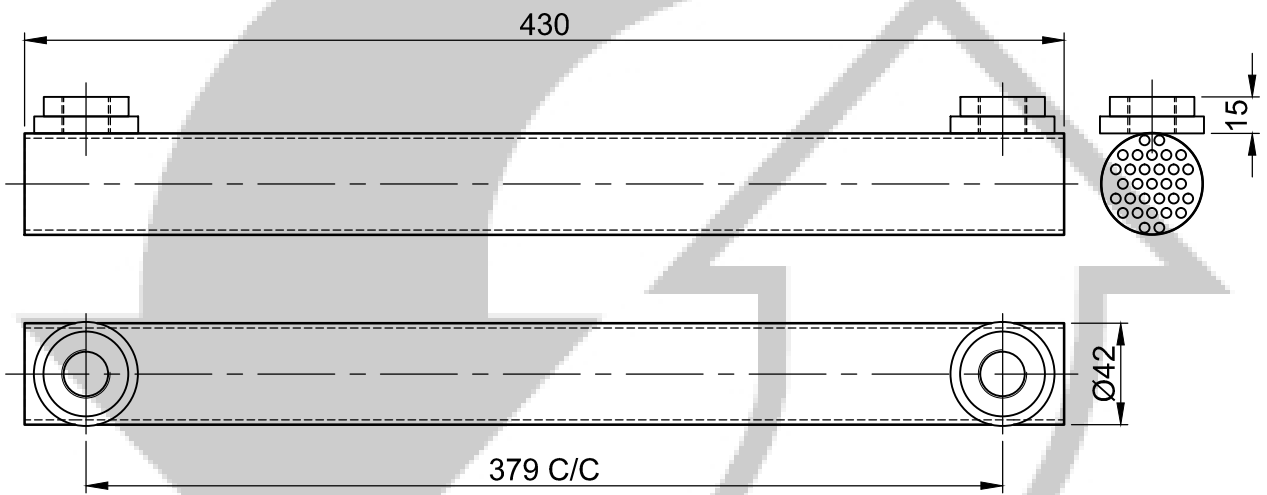

MODEL:HYSTER

PART NUMBER:TMOC430HYS1COM

TRANSMISSION OILCOOLER-LAND ROVER

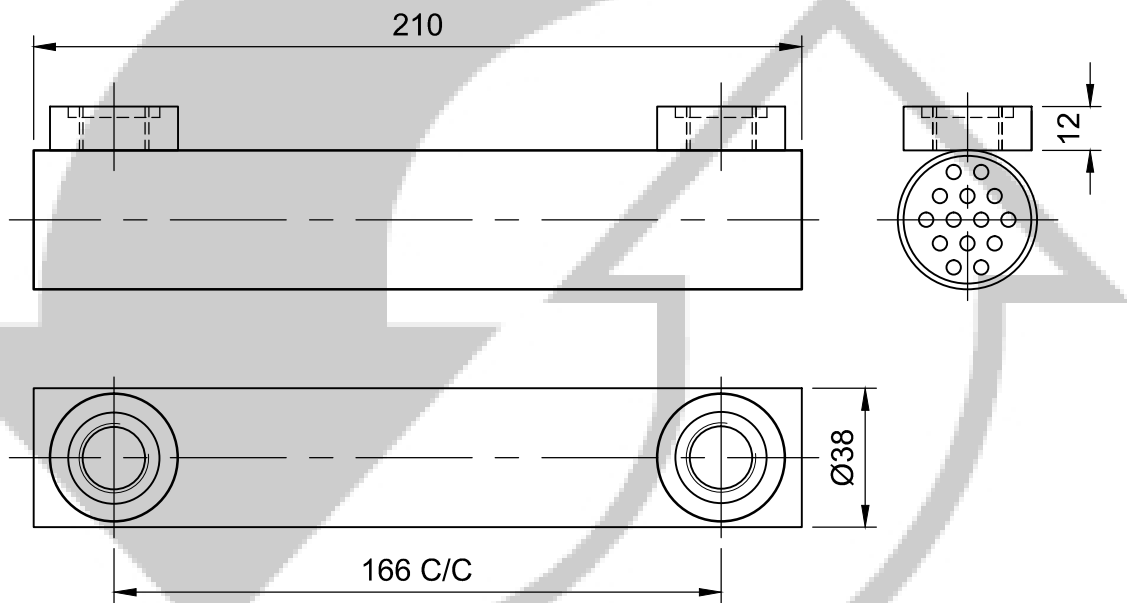

MODEL:LAND ROVER

PART NUMBER:TMOC-210LRO1COM

TRANSMISSION OILCOOLER-MAN

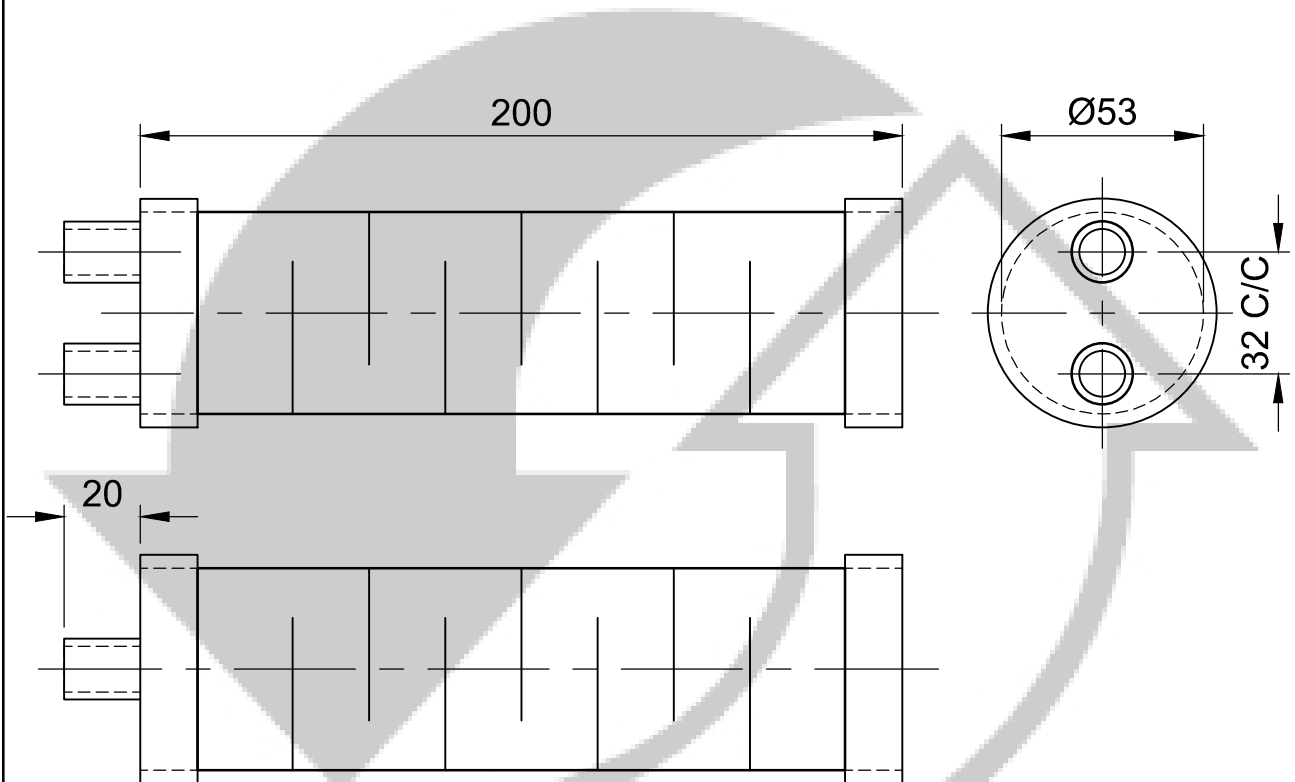

MODEL:MAN

PART NUMBER:TMOC-200MAN1COM

TRANSMISSION OILCOOLER-MERCEDES BENZ

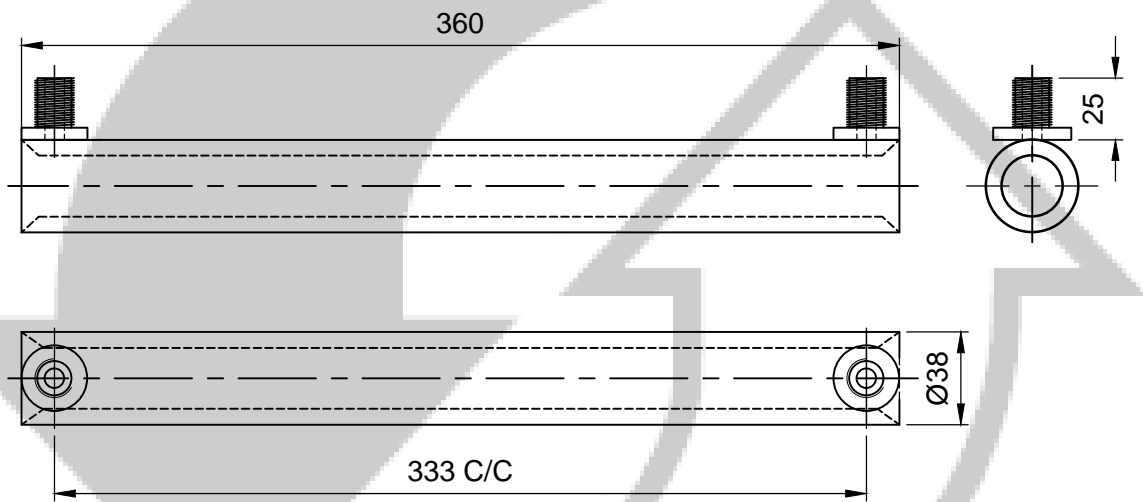

MODEL:MERCEDES BENZ

PART NUMBER:TMOC-DB360MER

TRANSMISSION OILCOOLER-MERCEDES BENZ

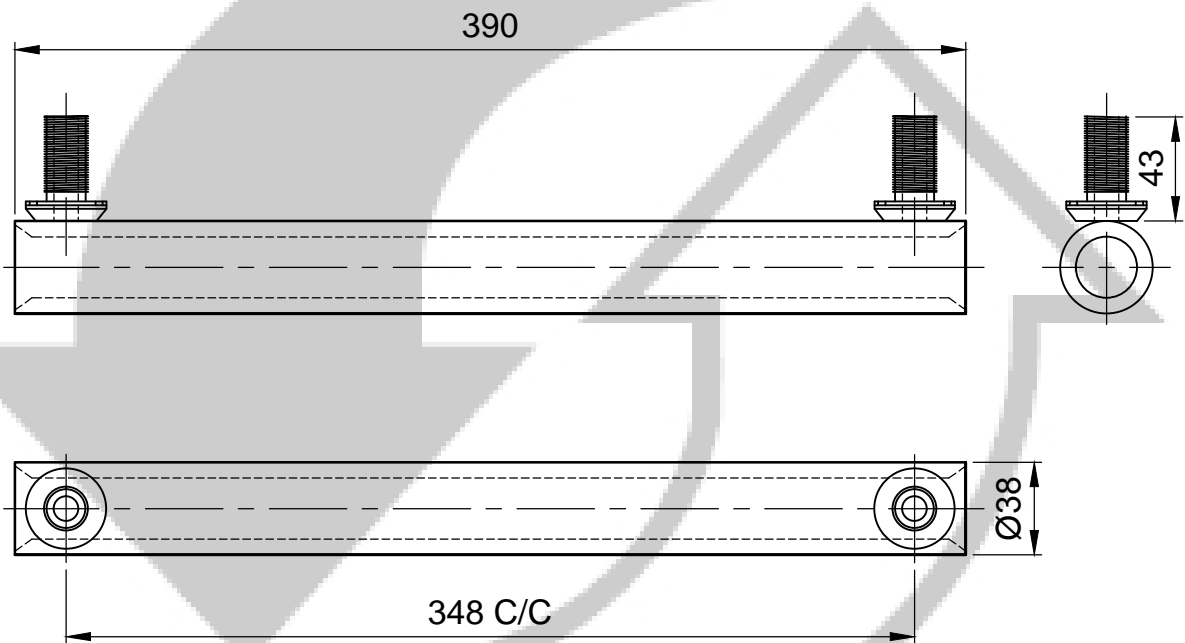

MODEL:MERCEDES BENZ

PART NUMBER:TMOC-DB390MER SCREW ON

TRANSMISSION OILCOOLER-MERCEDES BENZ

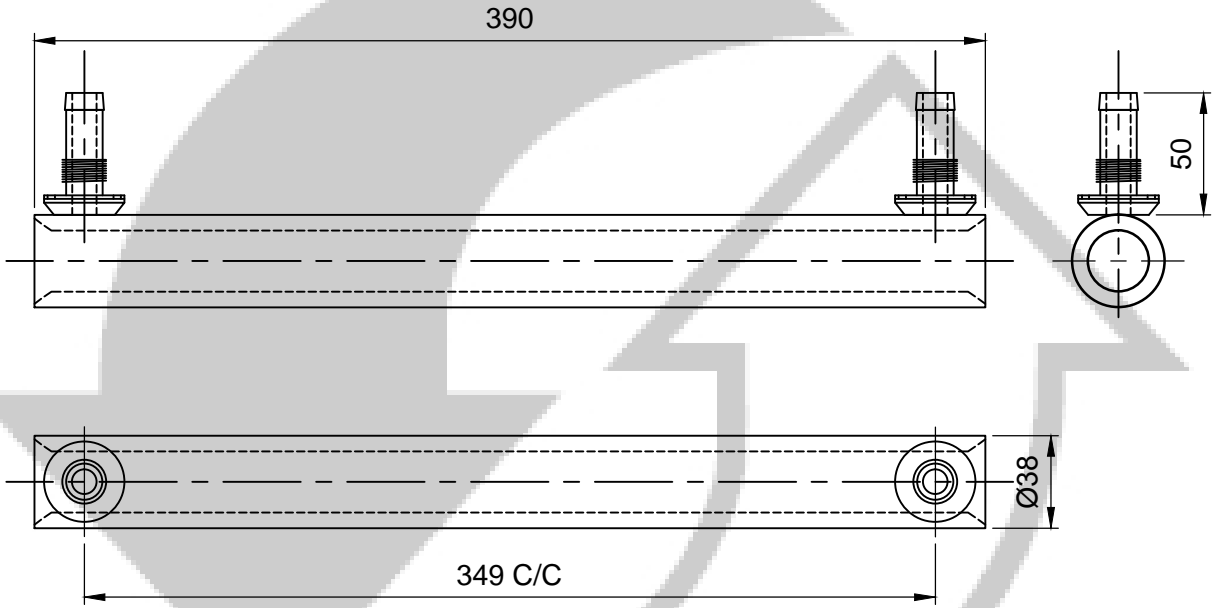

MODEL:MERCEDES BENZ

PART NUMBER:TMOC-DB390MER CLIP-ON

TRANSMISSION OILCOOLER-MERCEDES BENZ

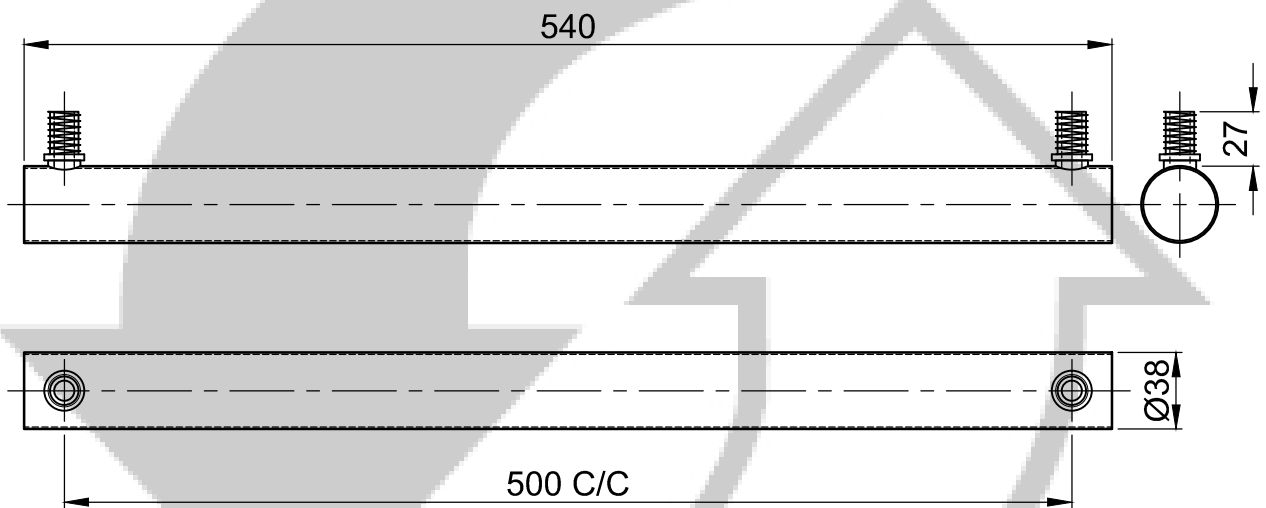

MODEL:MERCEDES BENZ_ACTROS

PART NUMBER:TMOC-DB540MER1COM

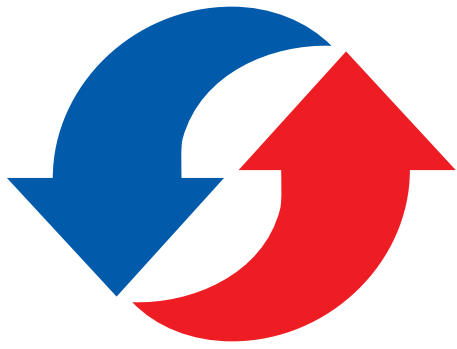

CHE

HEAT TRANSFER PRODUCTS

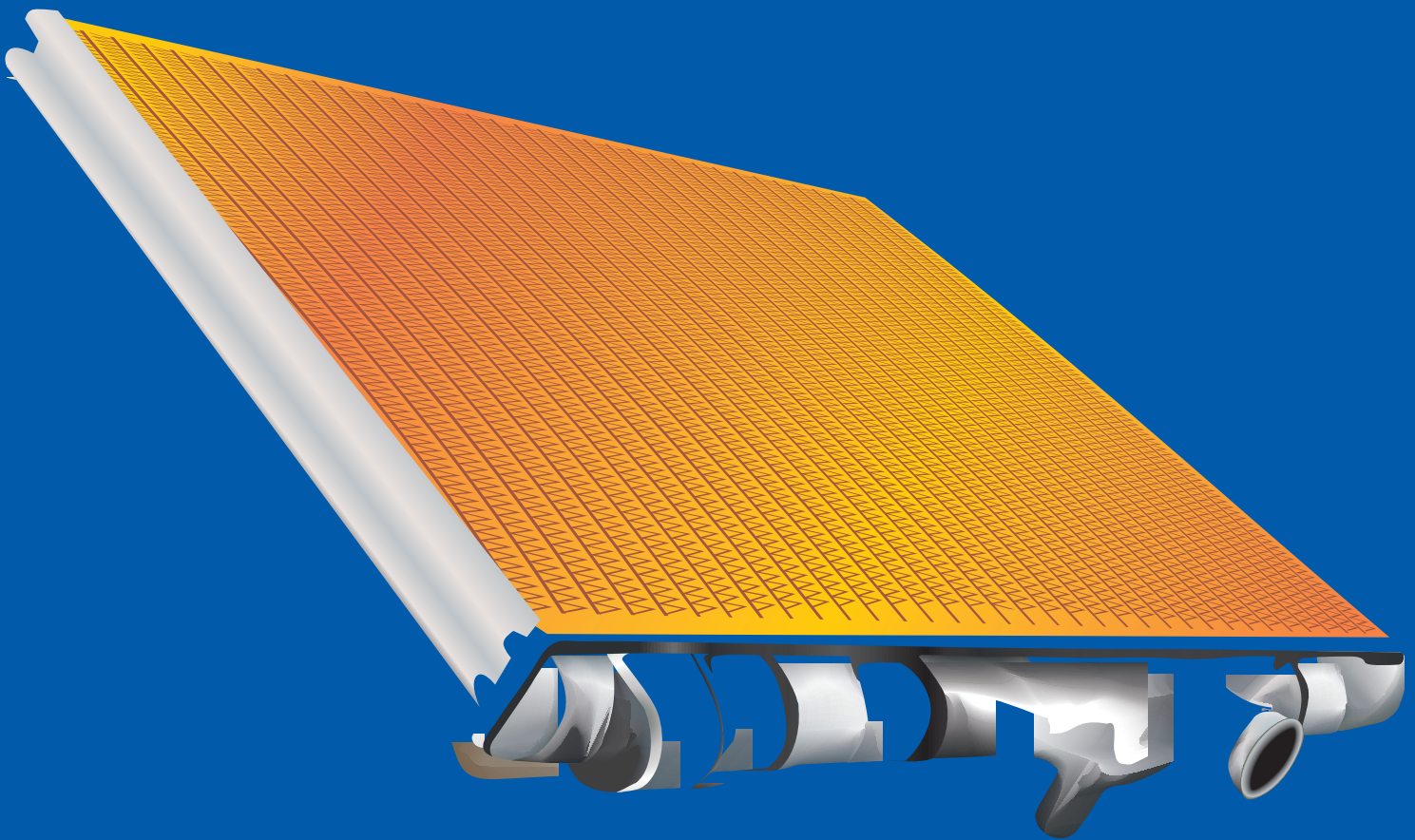

RADIATORS

www.CHE.co.za

RADIATOR-AUSTIN

Cape Heat Exchange is proud to announce the newly developed aluminium **Austin Healey 100-6 and 3000 radiator**. The radiator was developed as a replacement radiator to the classic Austin Healey 100-6 (1959-1959) and 3000 (1959-1967) model. The original radiator is a copper unit and to improve on its cooling performance, overall weight and price an all-aluminium radiator was developed by using technology that is currently available. It is a tube and bar system, with the tubes being thick walled extrusions and there are no header plates. This radiator will take care of any overheating problems and ensure the user can enjoy driving this beautiful vintage car.

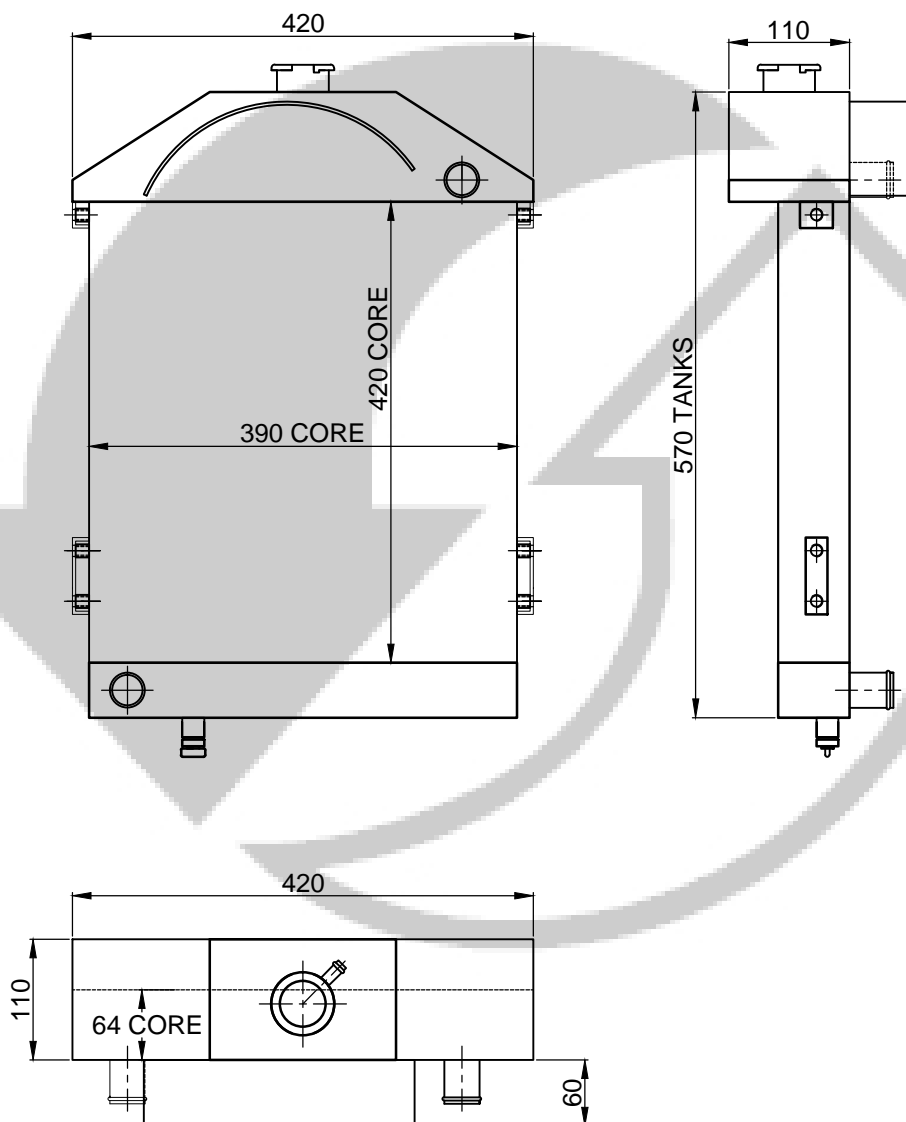

MODEL:AUSTIN HEALEY 100/6 AND 3000

PART NUMBER:RAD420AUS1COM

RADIATOR-BELL

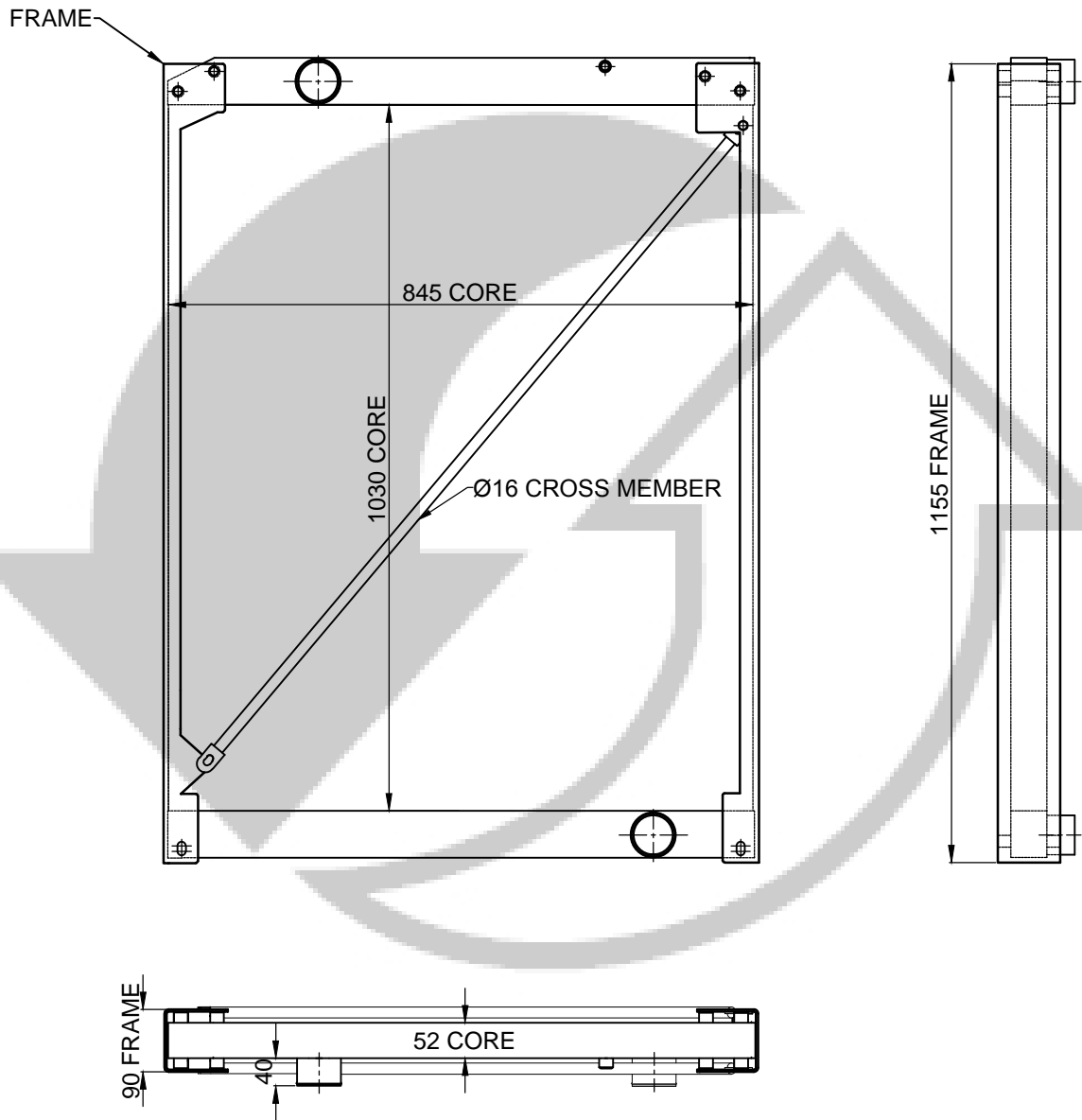

MODEL: BELL DUMPER

PART NUMBER: RAD1030BEL1COM

RADIATOR-CATERPILLAR

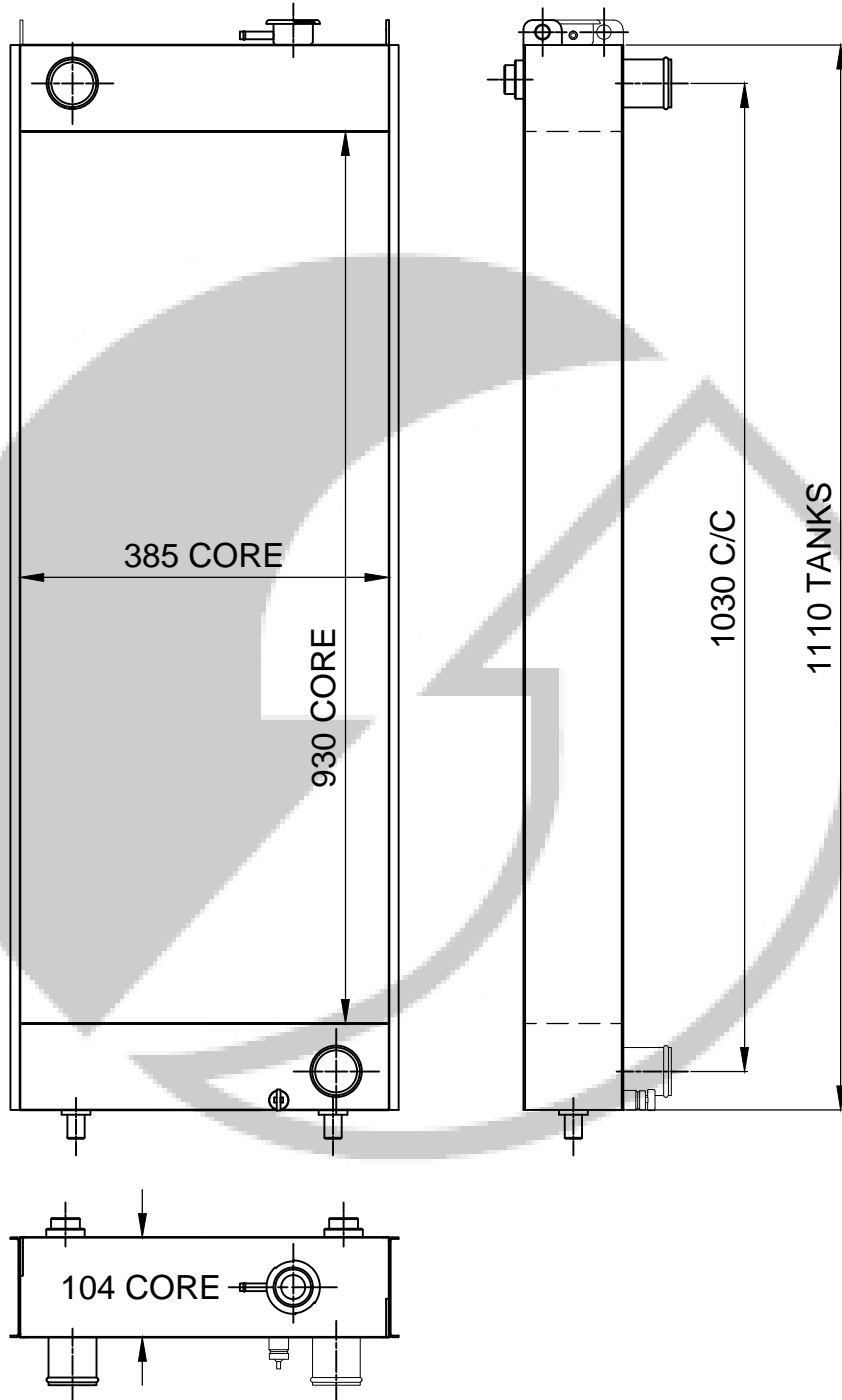

MODEL:CATERPILLAR 320L

PART NUMBER:RAD930CAT1COM

RADIATOR-FREIGHTLINER

Cape Heat Exchange is proud to announce the newly developed aluminium *Freightliner Argosy radiator*. The radiator was developed with South African temperatures and road conditions in mind. It is a tube and bar system. The tubes are thick walled extrusions and there are **no header plates**, this reduces the interfaces that might cause leakages and we are confident that this is the **strongest Freightliner radiator** on the market. Different to the OEM and aftermarket radiator, this radiator is entirely made of aluminium with no plastic tanks. The aluminium tanks are similar in weight to the plastic tanks and because they are welded to the core it increases the strength and durability of the complete radiator.

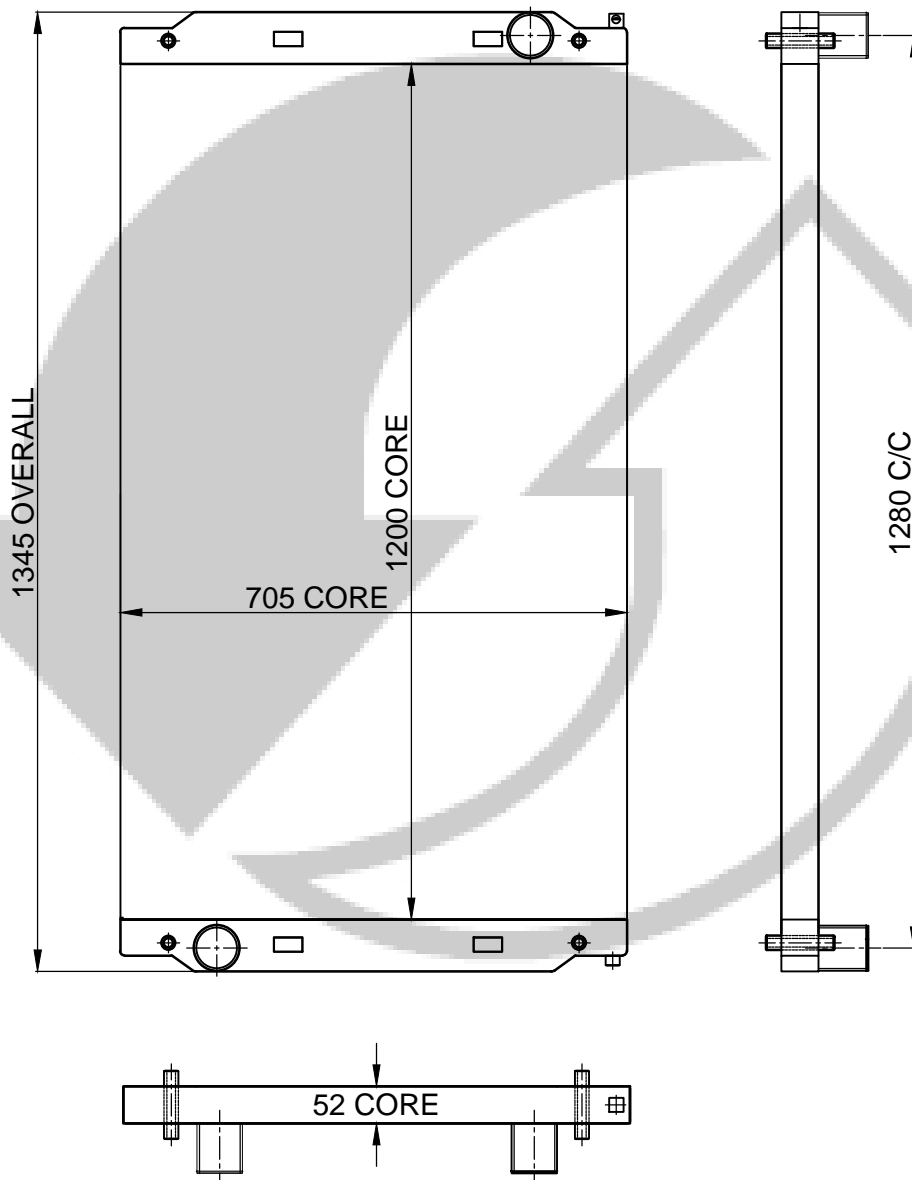

MODEL:FREIGHTLINER ARGOSY

PART NUMBER:RAD1200FR1COM

RADIATOR-HITACHI

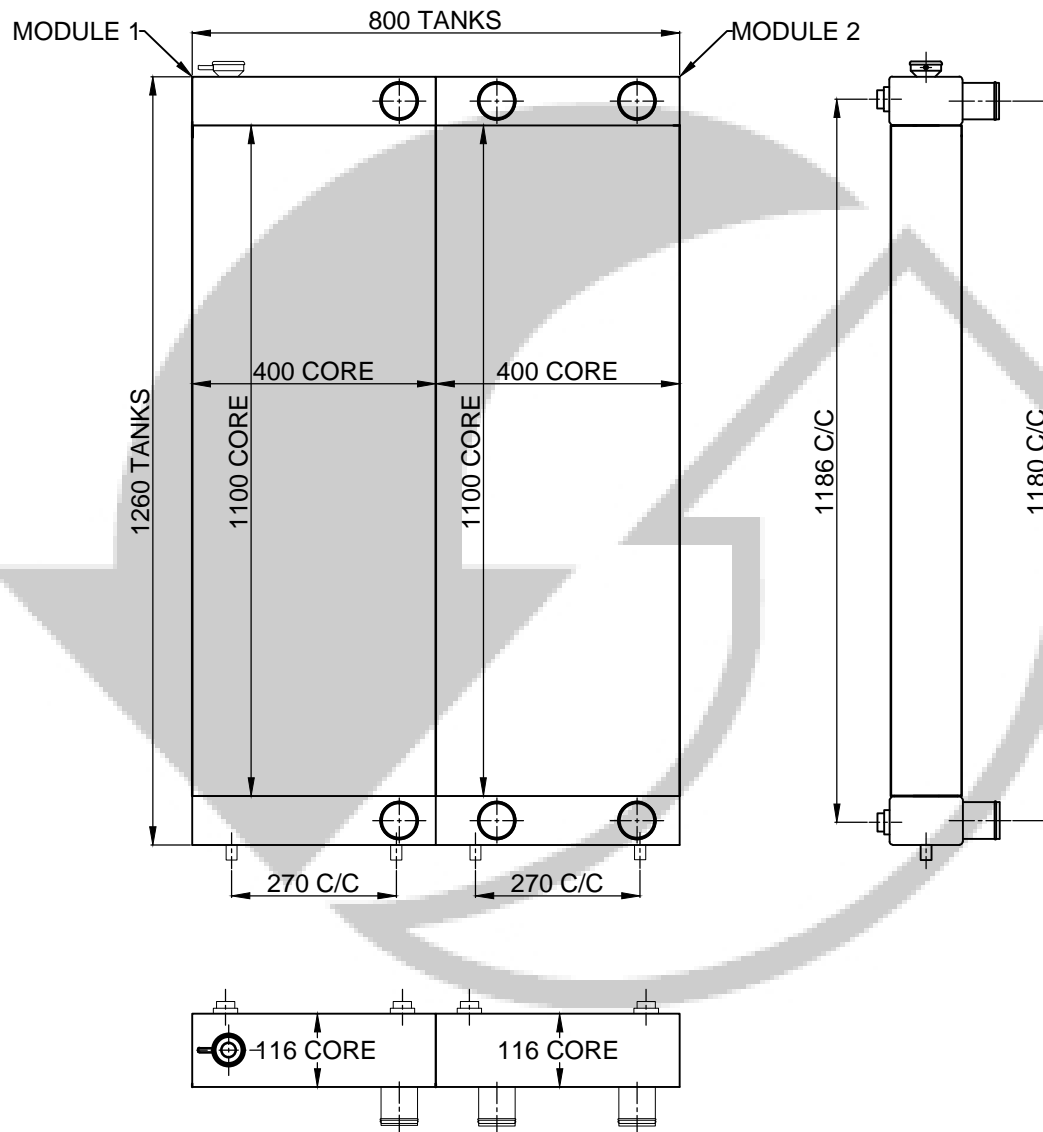

MODEL:HITACHI ZX680

PART NUMBER:RAD1100HIT1COM

RADIATOR-HITACHI

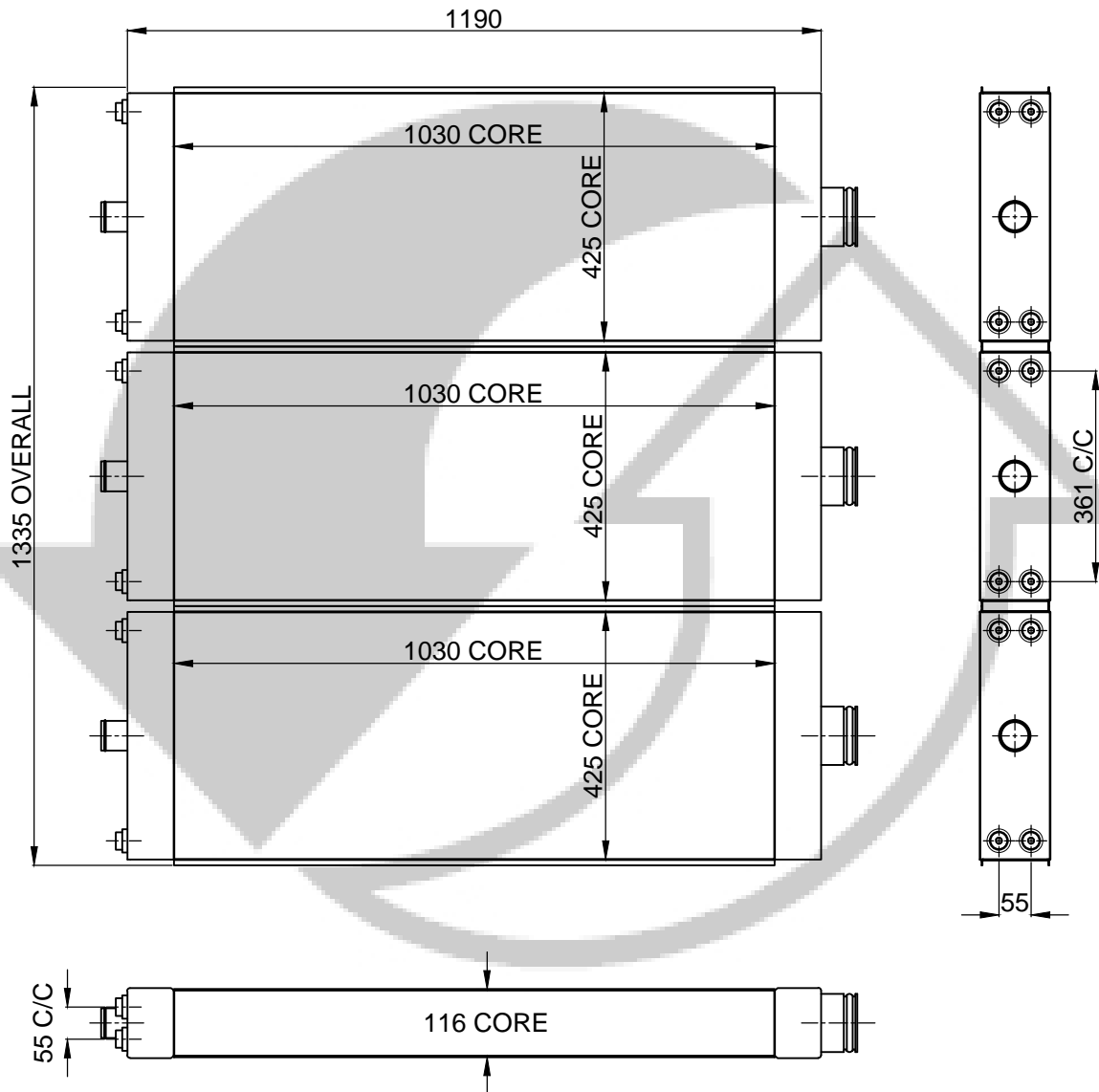

MODEL:HITACHI ZX870

PART NUMBER:RAD1030HIT1COM

RADIATOR-INTERNATIONAL

Cape Heat Exchange is proud to announce the newly developed aluminium *International Eagle radiator*. The radiator was developed with South African temperatures and road conditions in mind. As this unit is utilized in trucks that mostly travel long distances durability is of utmost importance. It is a tube and bar system. The tubes are thick walled extrusions and there are **no header plates**, this reduces the interfaces that might cause leakages and we are confident that this is the **strongest International Eagle radiator** on the market. Different to the OEM and aftermarket radiator, this radiator is entirely made of aluminium with no plastic tanks. The aluminium tanks are similar in weight to the plastic tanks and because they are welded to the core it increases the strength and durability of the complete radiator.

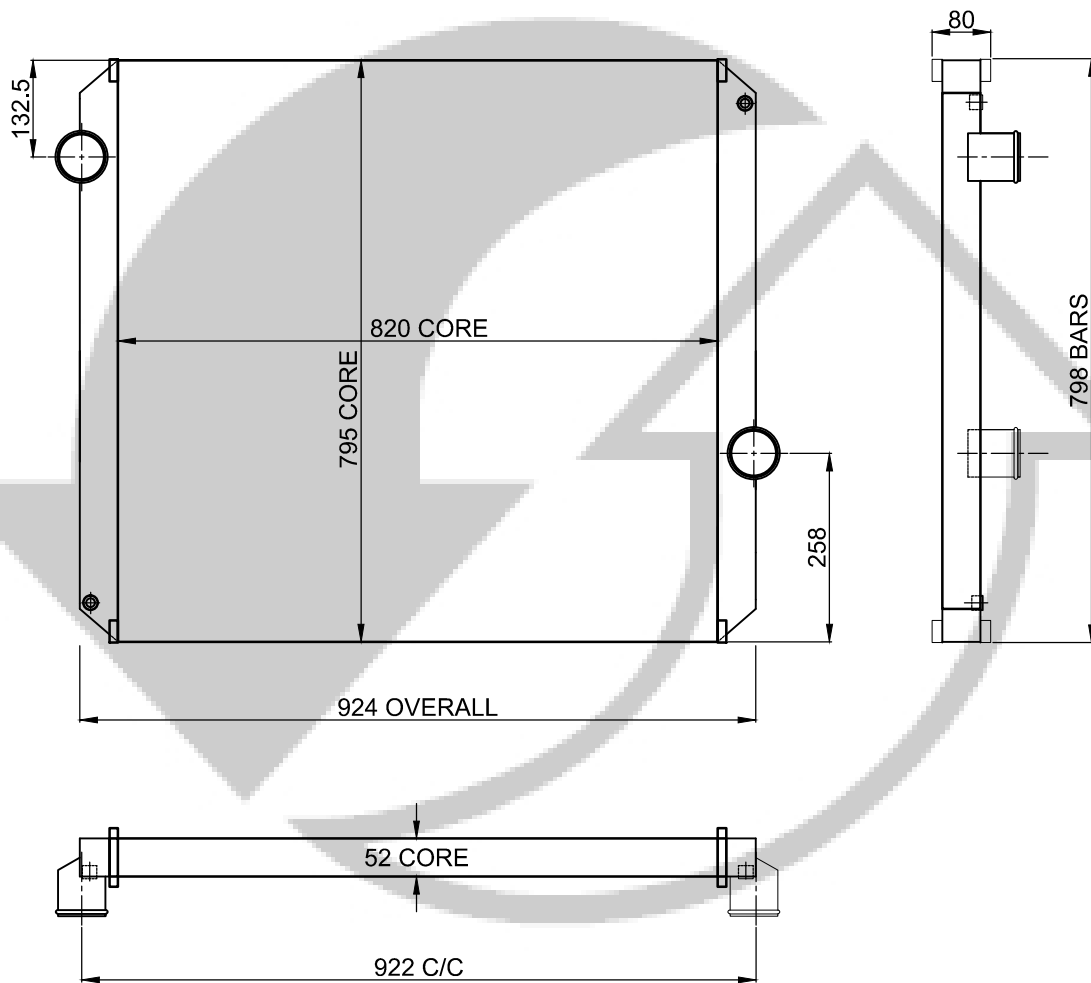

MODEL:INTERNATIONAL EAGLE 9800i

PART NUMBER:RAD820INT1COM

RADIATOR-ISUZU

Is your Isuzu FXZ truck working in harsh conditions? Or do you just want to add more durability to your fleet?

Cape Heat Exchange is proud to announce the newly developed **Isuzu FXZ truck Radiator** (RAD880ISU1COM). The unit was developed with harsh operating conditions and durability in mind.

The tanks are made from aluminium, thus it is stronger than the standard plastic tanks but similar in weight. This radiator doesn't consist of any header plates, the aluminium tanks are directly welded to the core which increases the strength and durability of the complete radiator. The core consist of a tube and bar system and the tubes are thick walled extrusions.

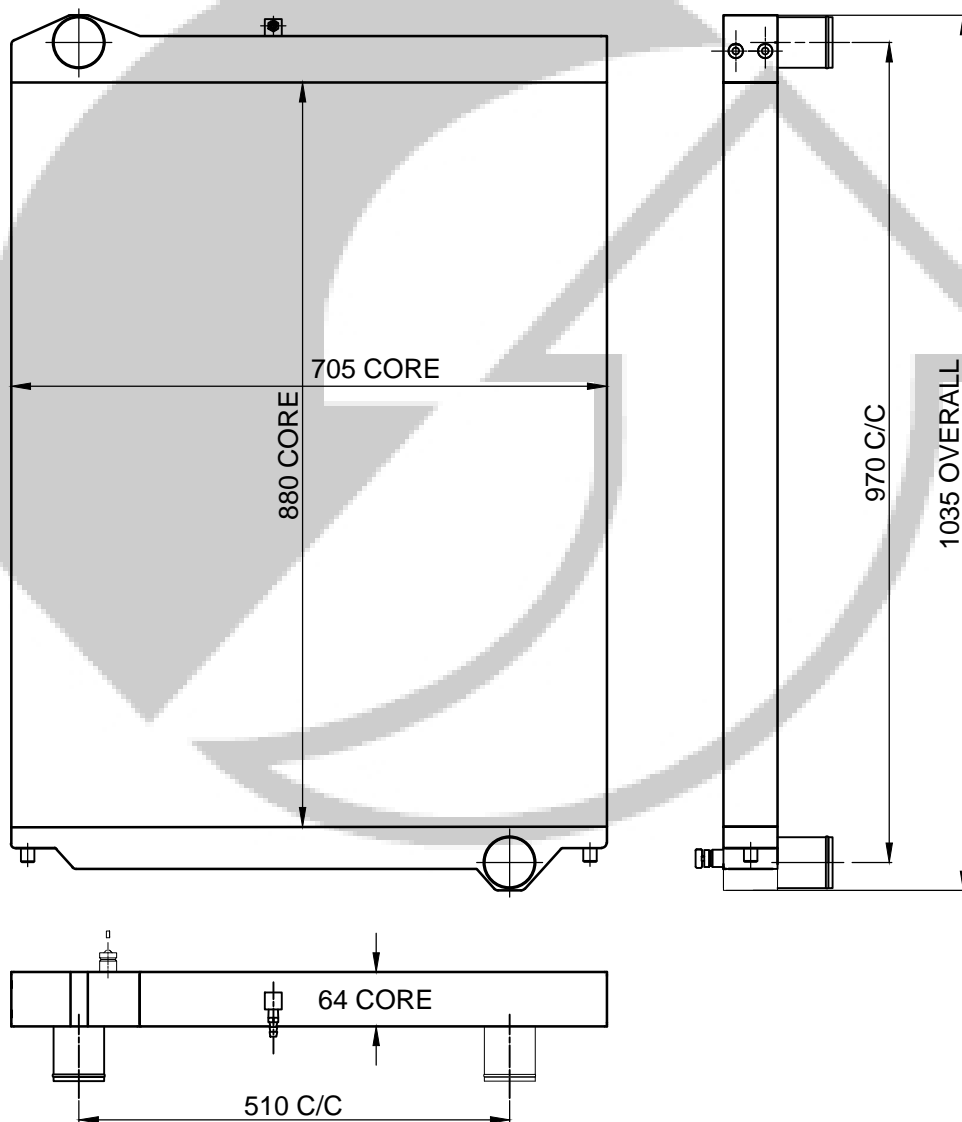

MODEL:ISUZU FXZ

PART NUMBER:RAD880ISU1COM

RADIATOR-KOMATSU

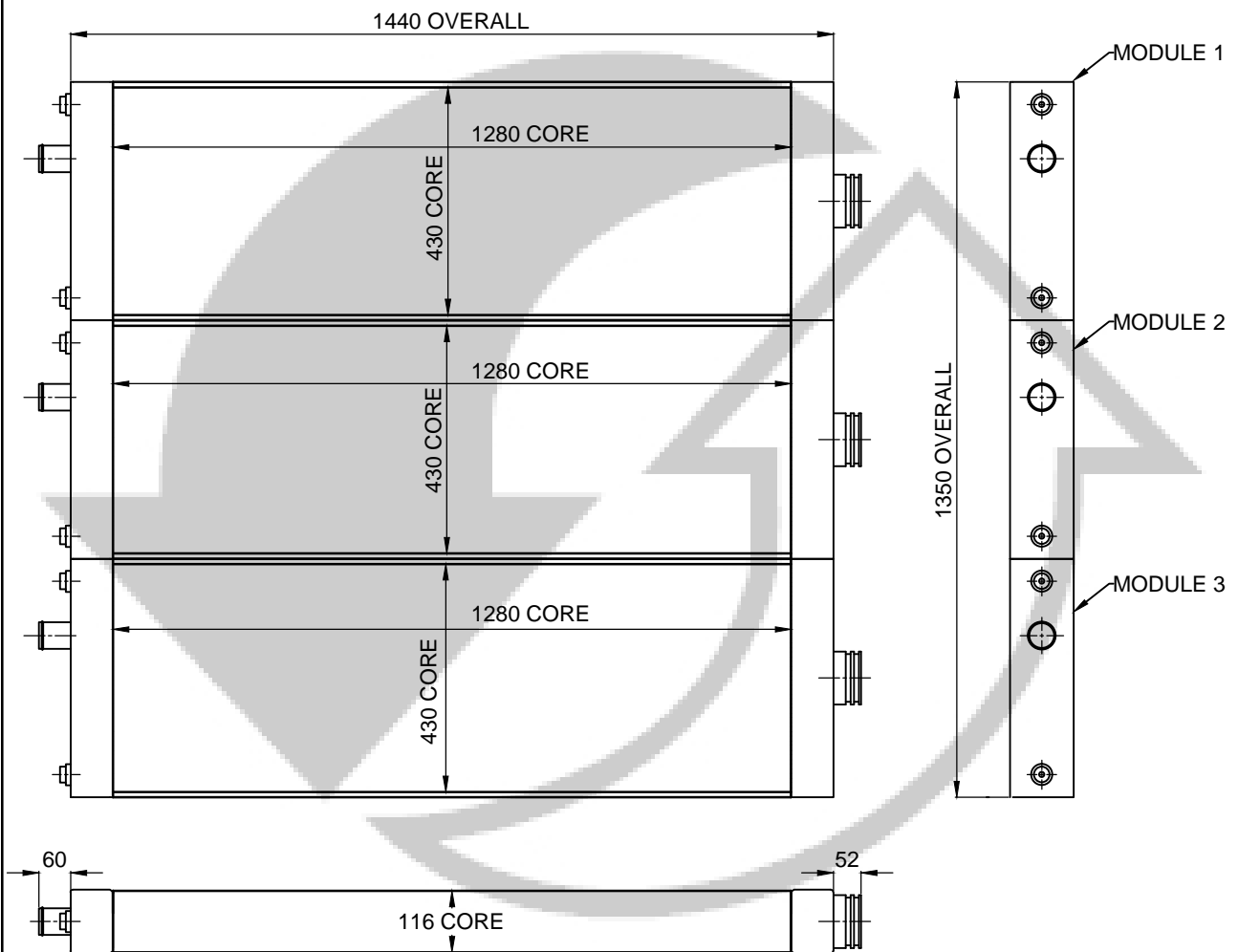

MODEL:KOMATSU D375

PART NUMBER:RAD1280KOM1COM

RADIATOR-KOMATSU

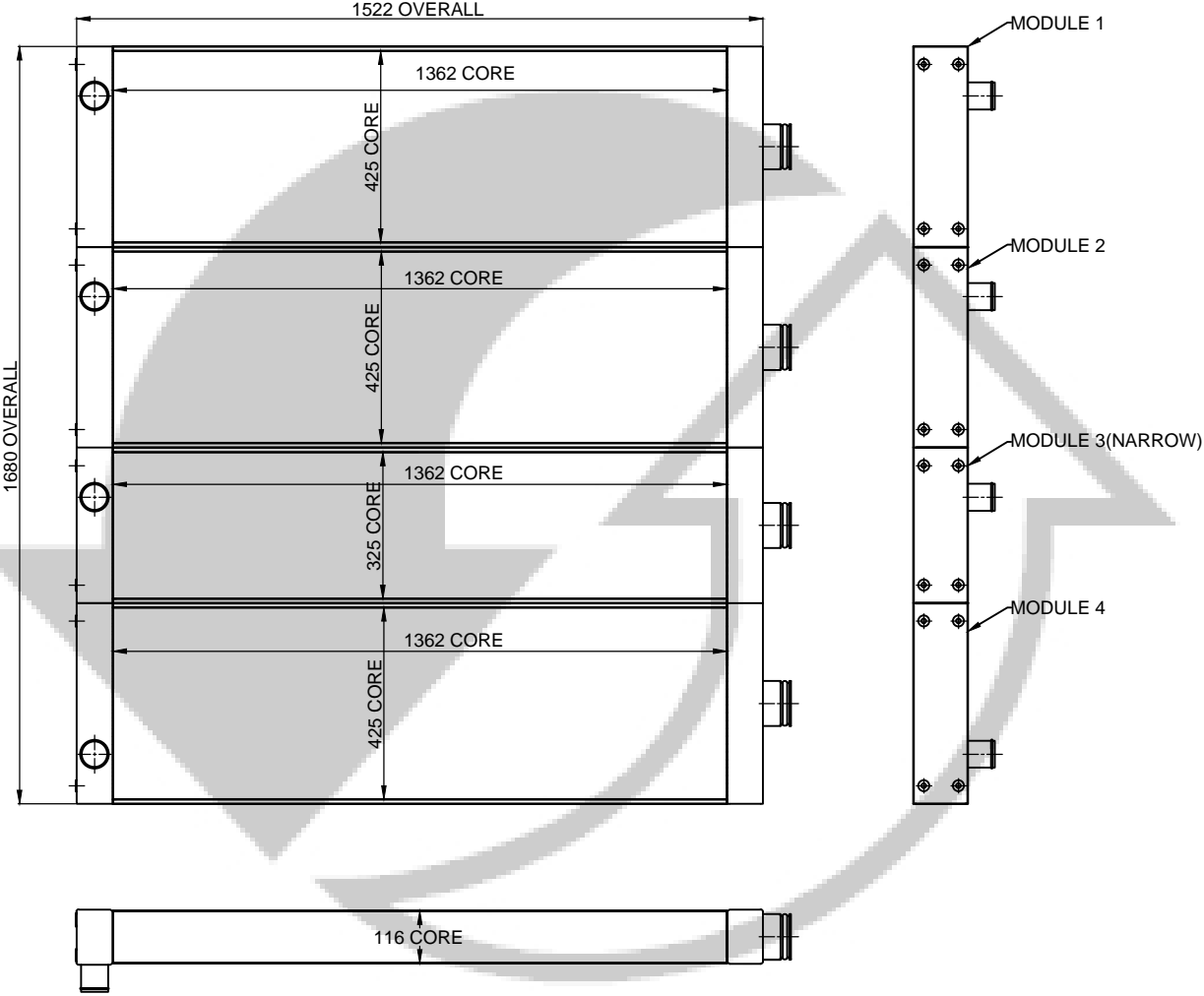

MODEL:KOMATSU D785

PART NUMBER:RAD1362KOM1COM

RADIATOR- MAHINDRA

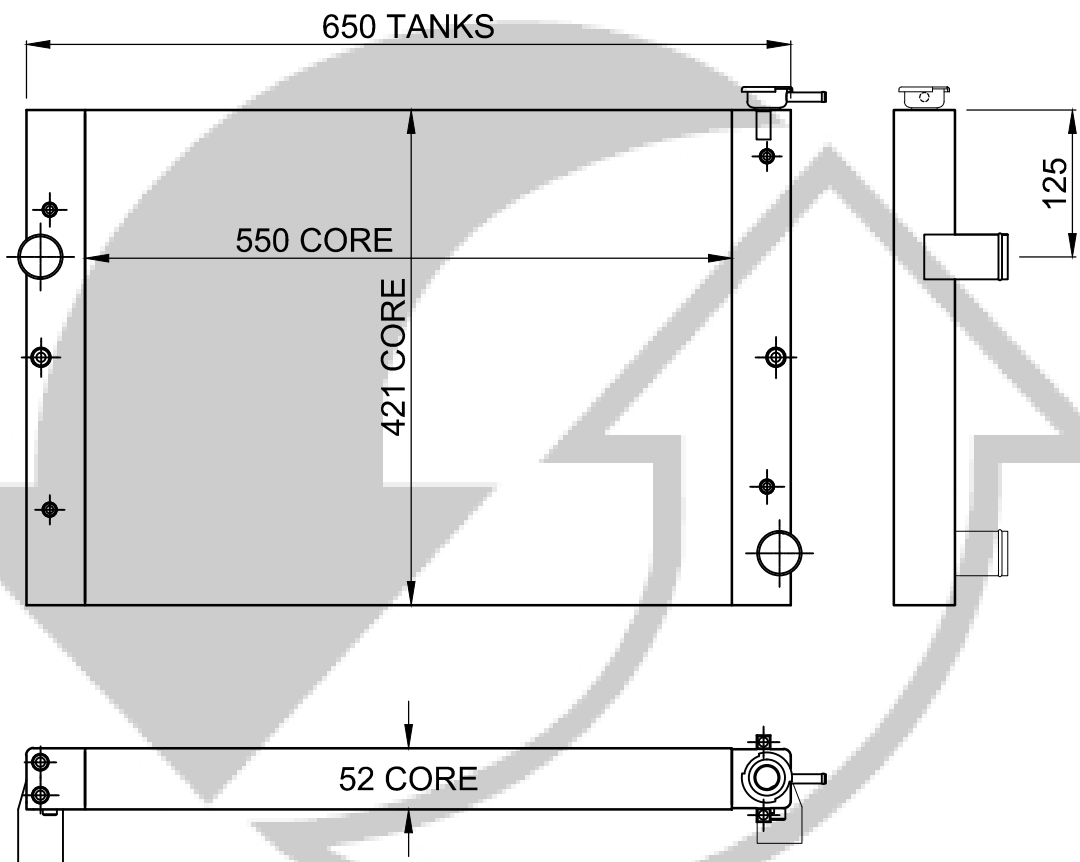

MODEL:MAHINDRA

PART NUMBER:RAD550MAH1COM

RADIATOR- MAHINDRA

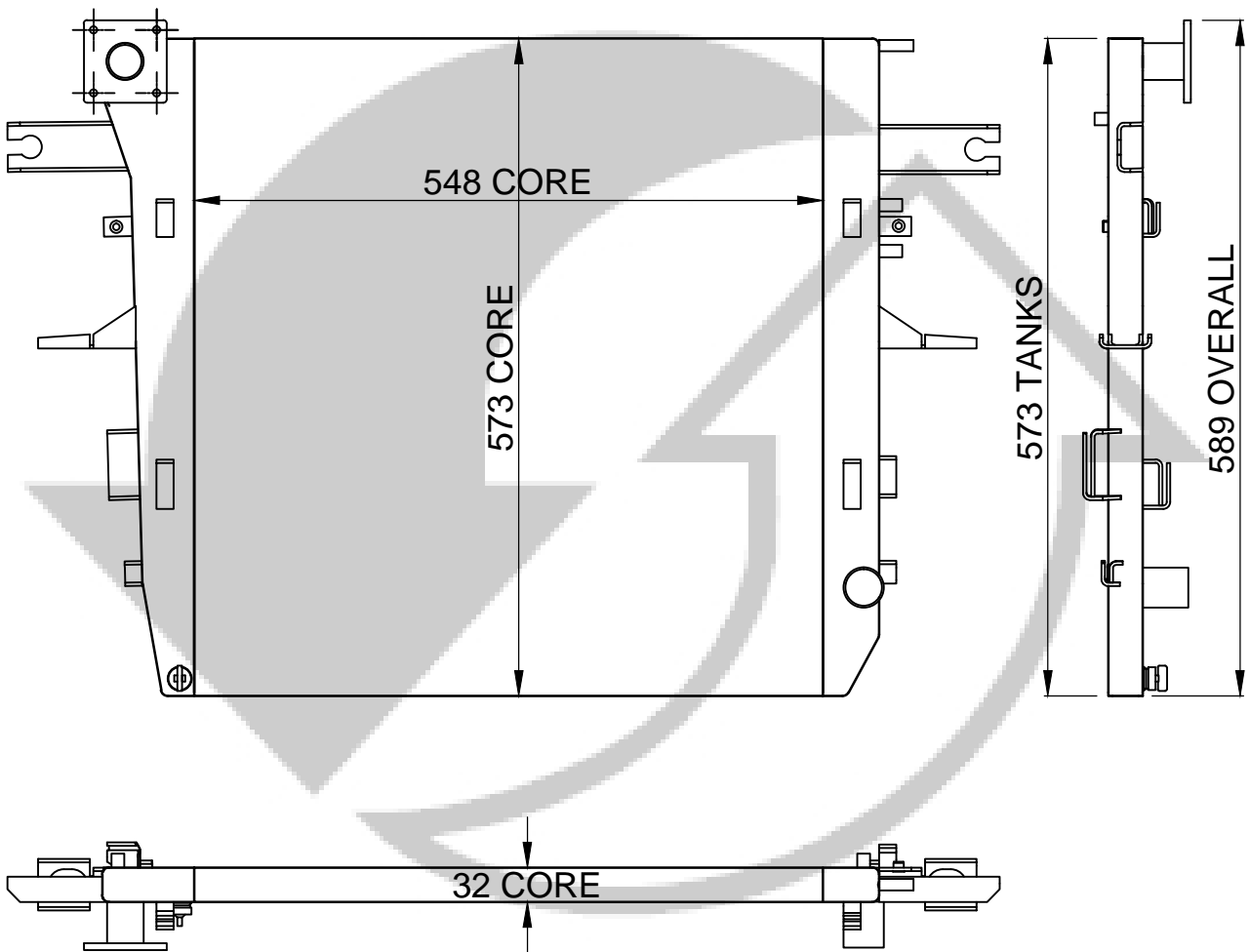

MODEL:MAHINDRA

PART NUMBER:RAD548MAH1COM

RADIATOR-MAN

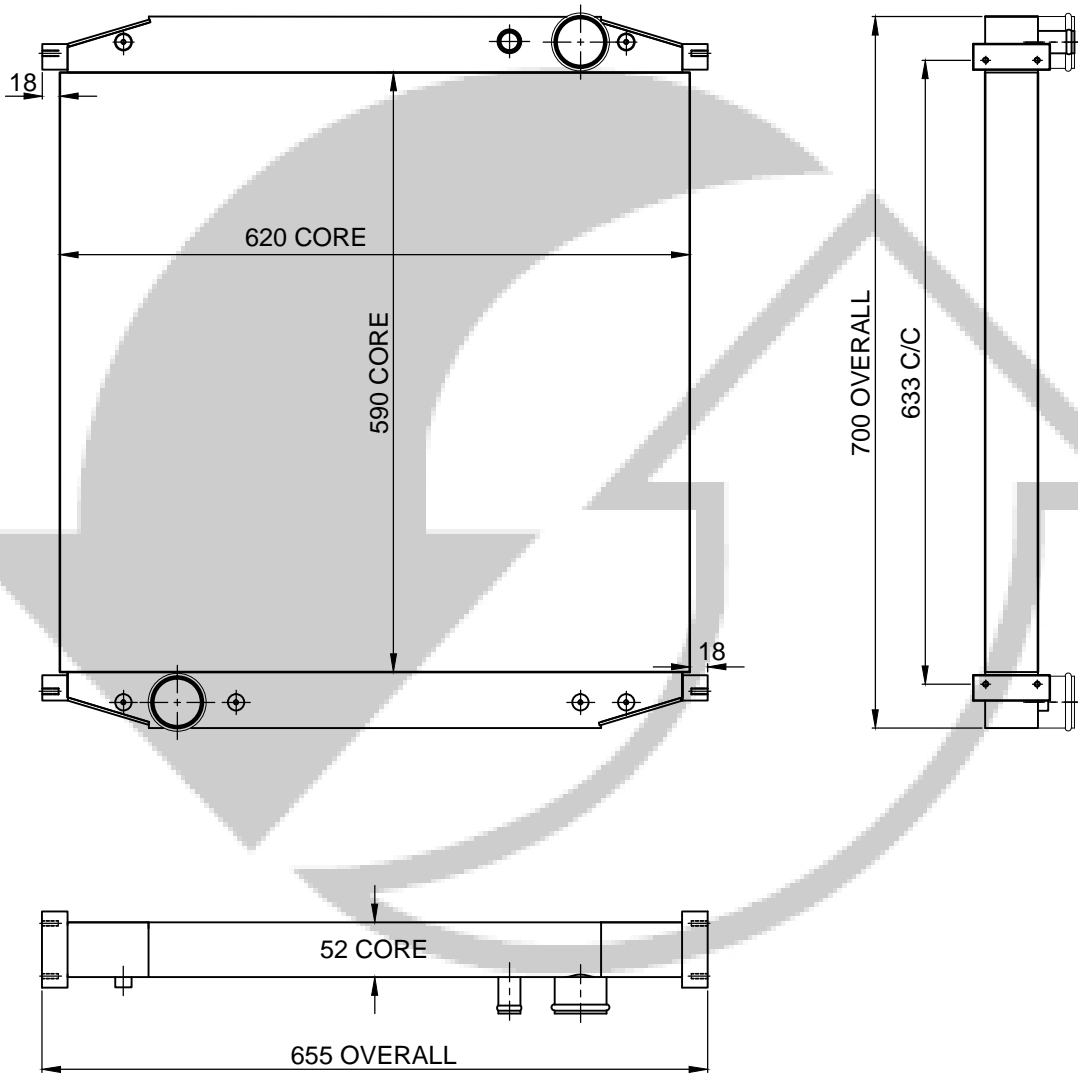

MODEL:590 MAN CLA RANGE V1

PART NUMBER:RAD590MAN1COM

RADIATOR-MAN

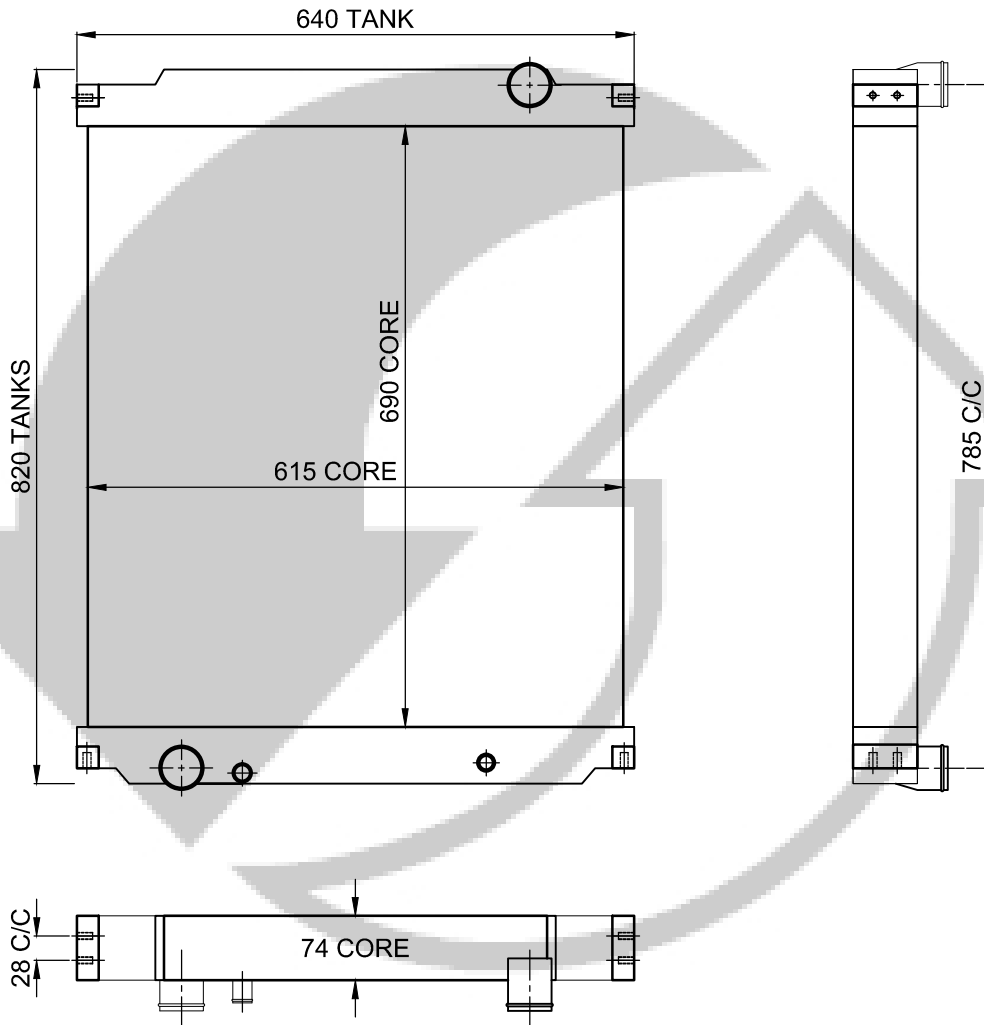

MODEL:690 MAN CLA V2

PART NUMBER:RAD690MAN1COM

RADIATOR-MAN

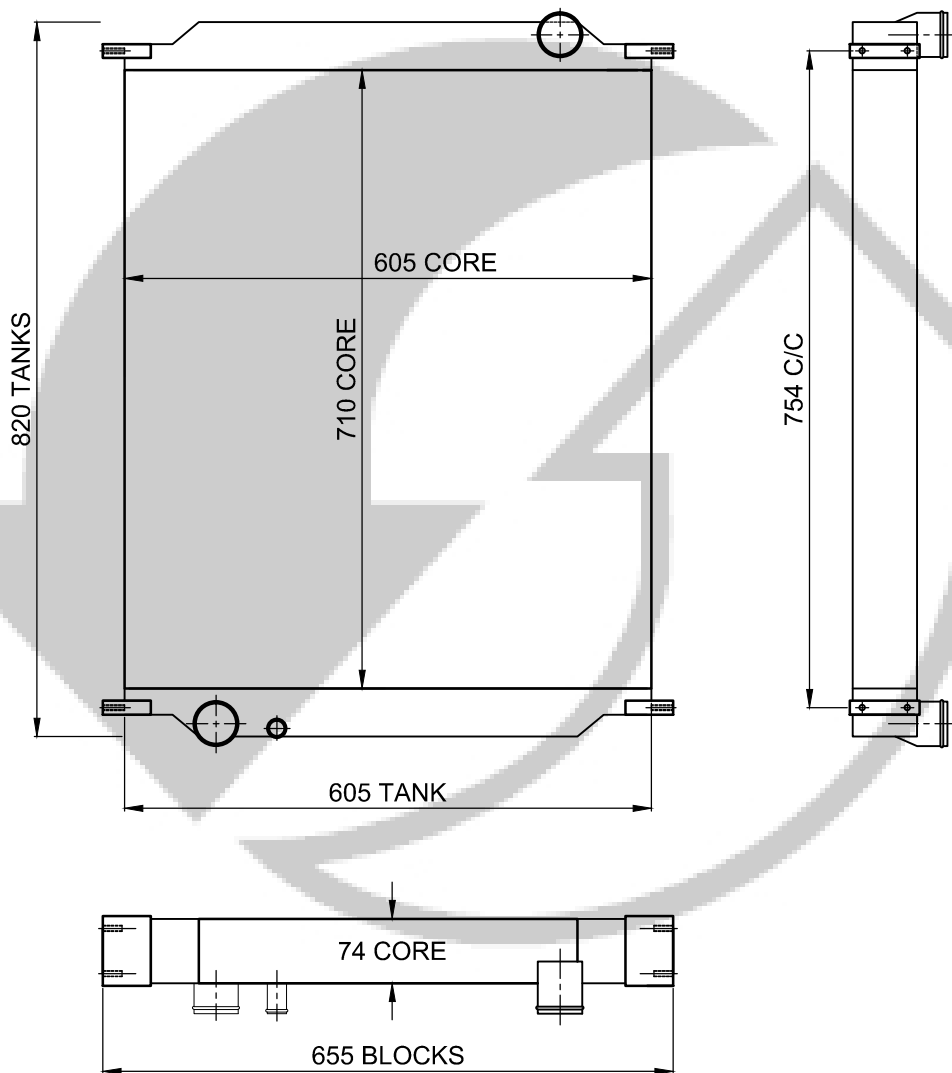

MODEL:710 MAN LE280 TGM RANGE

PART NUMBER:RAD710MAN1COM

RADIATOR-MORGAN

Cape Heat Exchange is proud to announce the newly developed aluminium **Morgan Plus 8 radiator**. The radiator was developed as a replacement radiator to the classic Morgan Plus 8 (1968-present) model. The original radiator is a copper unit and this specific model Morgan was renowned for overheating problems and as a result this improved radiator was developed by using technology that is currently available. The complicated tanks were replicated and as such the user won't need to worry about modifications that needs to be made. It is a tube and bar system, with the tubes being thick walled extrusions and there are no header plates. The radiator is entirely made of aluminium, it is cheaper and lighter than an original replacement and much more efficient. This radiator will enable the user to drive the car and simply enjoy the beauty of the past and technology of the future without worrying about overheating problems.

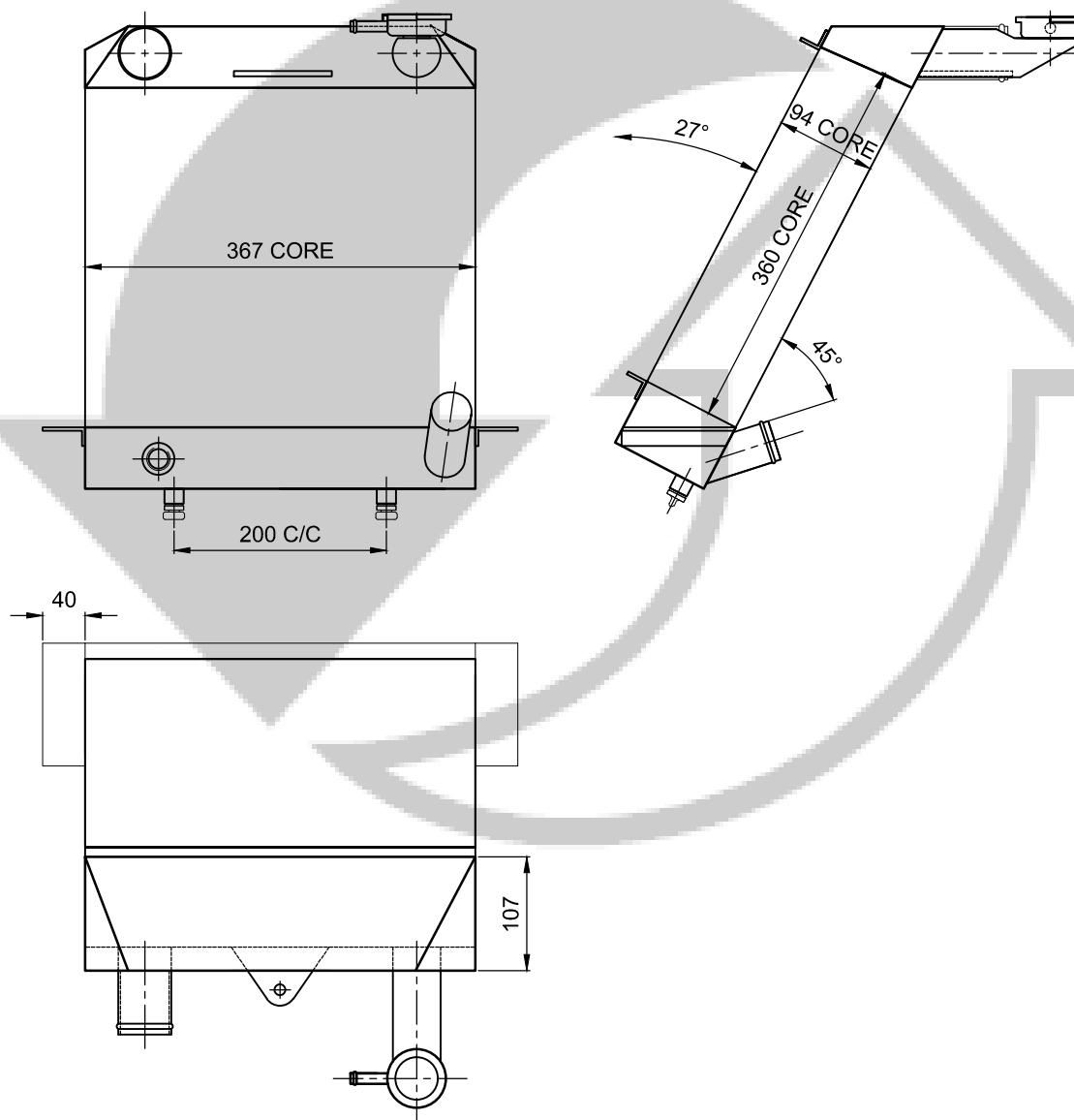

MODEL:MORGAN PLUS 8

PART NUMBER:RAD360MOR1COM

RADIATOR-NISSAN

Cape Heat Exchange is proud to announce the newly developed aluminium **Nissan UD 440**. The radiator was developed with South African temperatures and road conditions in mind. As this unit is utilized in trucks that mostly travel long distances durability is of utmost importance. It is a tube and bar system. The tubes are thick walled extrusions and there are **no header plates**, this reduces the interfaces that might cause leakages and we are confident that this is the **strongest Nissan UD 440 radiator** on the market. Different to the OEM and aftermarket radiator, this radiator is entirely made of aluminium with no plastic tanks. The aluminium tanks are similar in weight to the plastic tanks and because they are welded to the core it increases the strength and durability of the complete radiator.

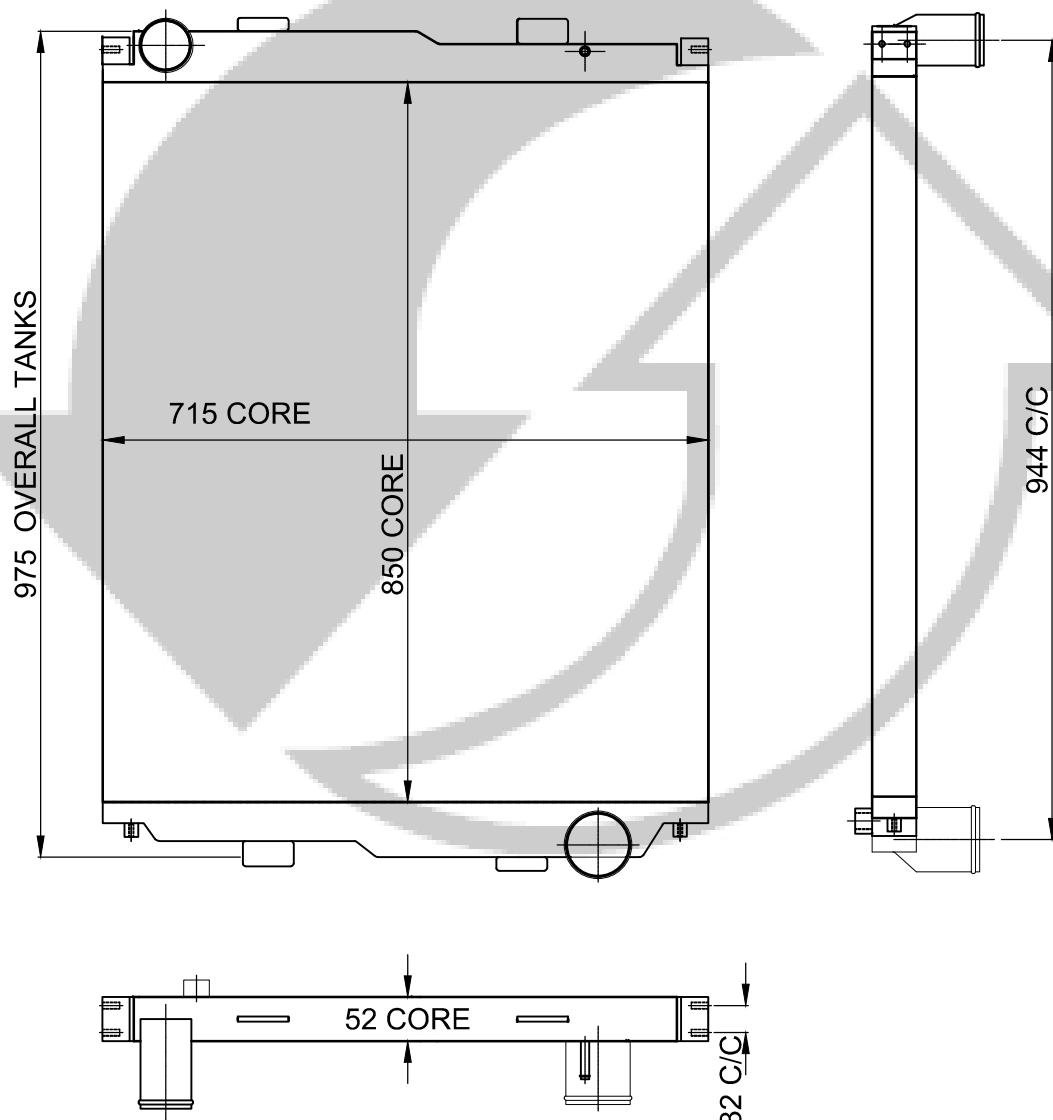

MODEL:NISSAN UD440

PART NUMBER:RAD850NIS1COM

RADIATOR-NISSAN

Cape Heat Exchange is proud to announce the newly developed aluminium **Nissan UD 370**. The radiator was developed with South African temperatures and road conditions in mind. As this unit is utilized in trucks that mostly travel long distances durability is of utmost importance. It is a tube and bar system. The tubes are thick walled extrusions and there are **no header plates**, this reduces the interfaces that might cause leakages and we are confident that this is the **strongest Nissan UD 370 radiator** on the market. Different to the OEM and aftermarket radiator, this radiator is entirely made of aluminium with no plastic tanks. The aluminium tanks are similar in weight to the plastic tanks and because they are welded to the core it increases the strength and durability of the complete radiator.

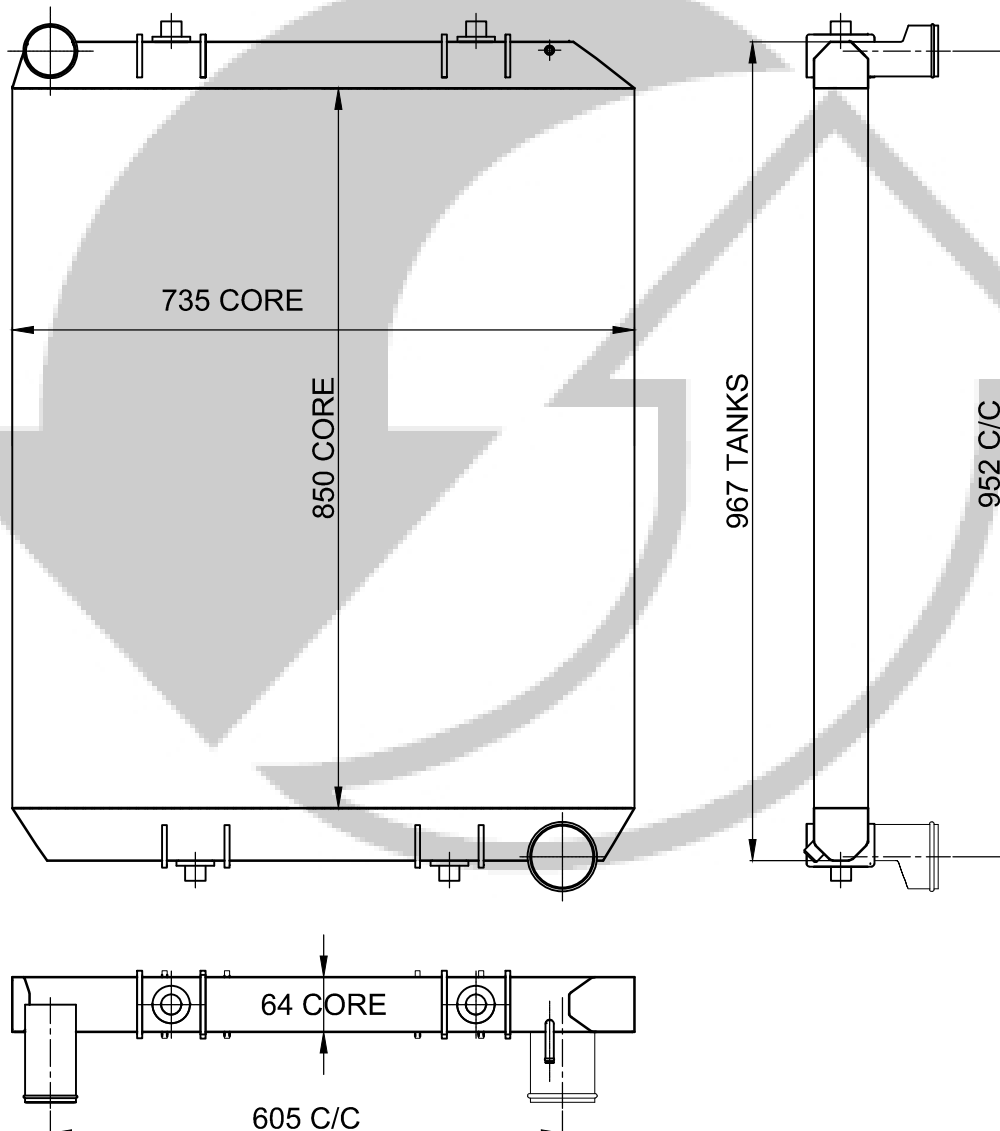

MODEL:NISSAN UD 370

PART NUMBER:RAD850NIS2COM

RADIATOR-SWIMMING POOL

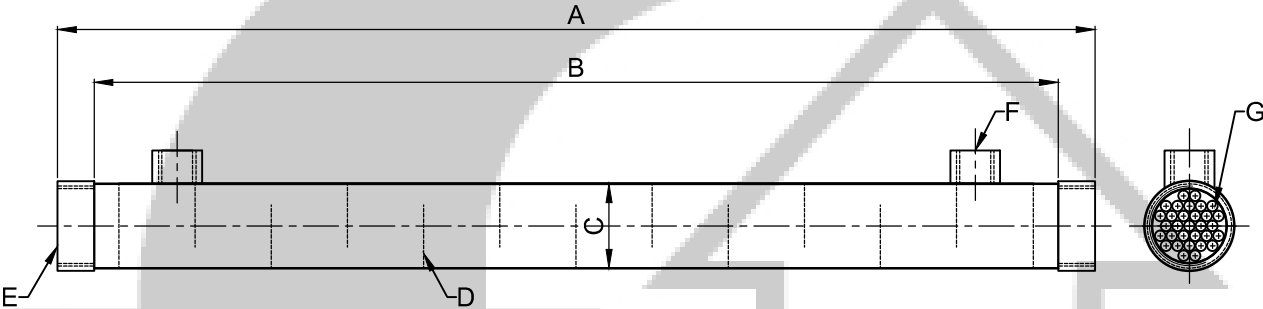

Model	A	B	C	D	E	F	G
5 KW	464	420	Ø50.8	7	1½" BSP	½" BSP	Ø6
10 KW	624	580	Ø50.8	11	1½" BSP	½" BSP	Ø6
15 KW	794	750	Ø50.8	15	1½" BSP	½" BSP	Ø6



MODEL:SWIMMING POOL COOLER

PART NUMBER: SP5 TO SP15

RADIATOR-TOYOTA

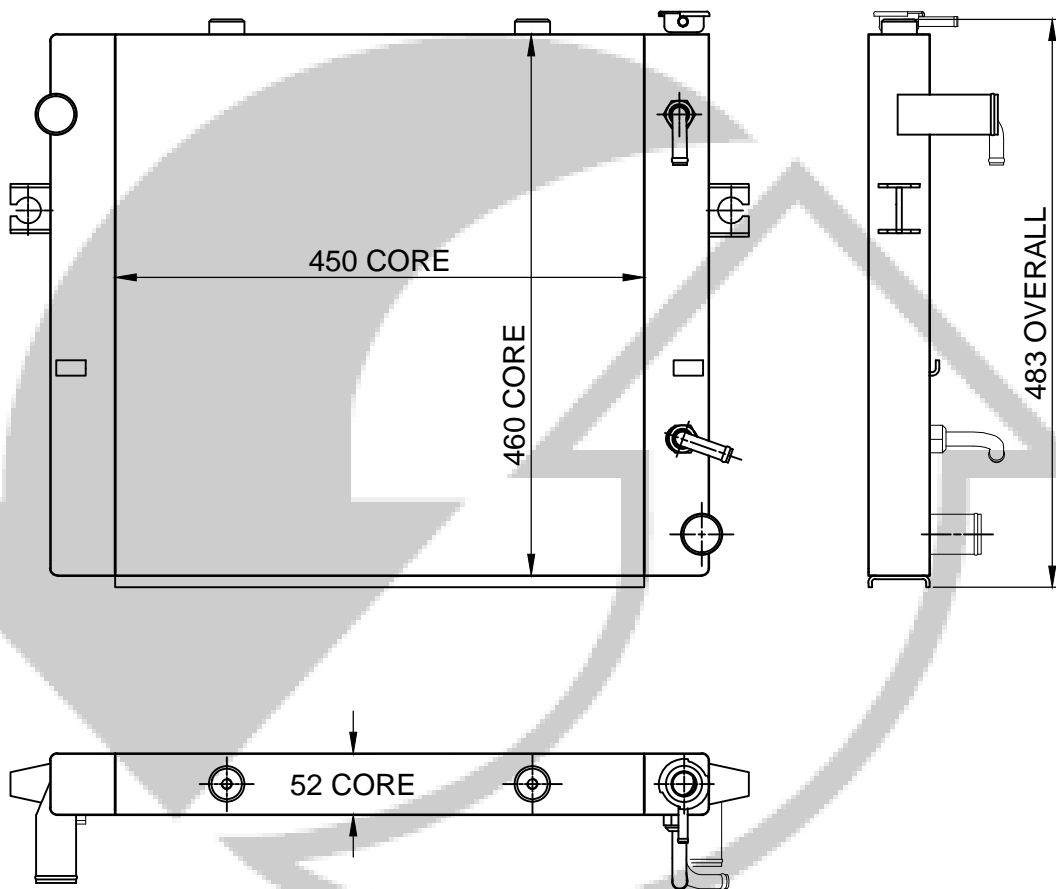

MODEL: TOYOTA FORKLIFT 1.8 TON

PART NUMBER: RAD450TOY1COM

RADIATOR-TOYOTA

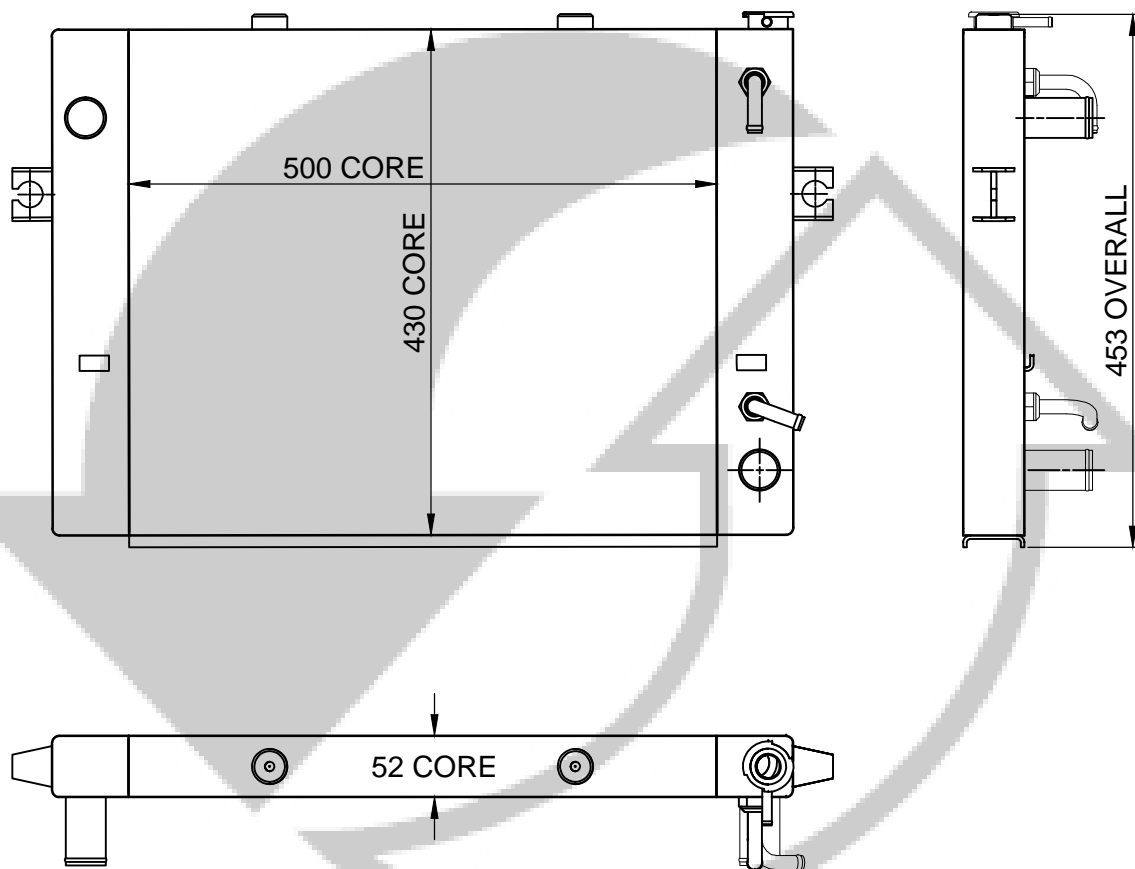

MODEL: TOYOTA FORKLIFT 2.5 TON

PART NUMBER: RAD500TOY1COM

RADIATOR-VOLVO

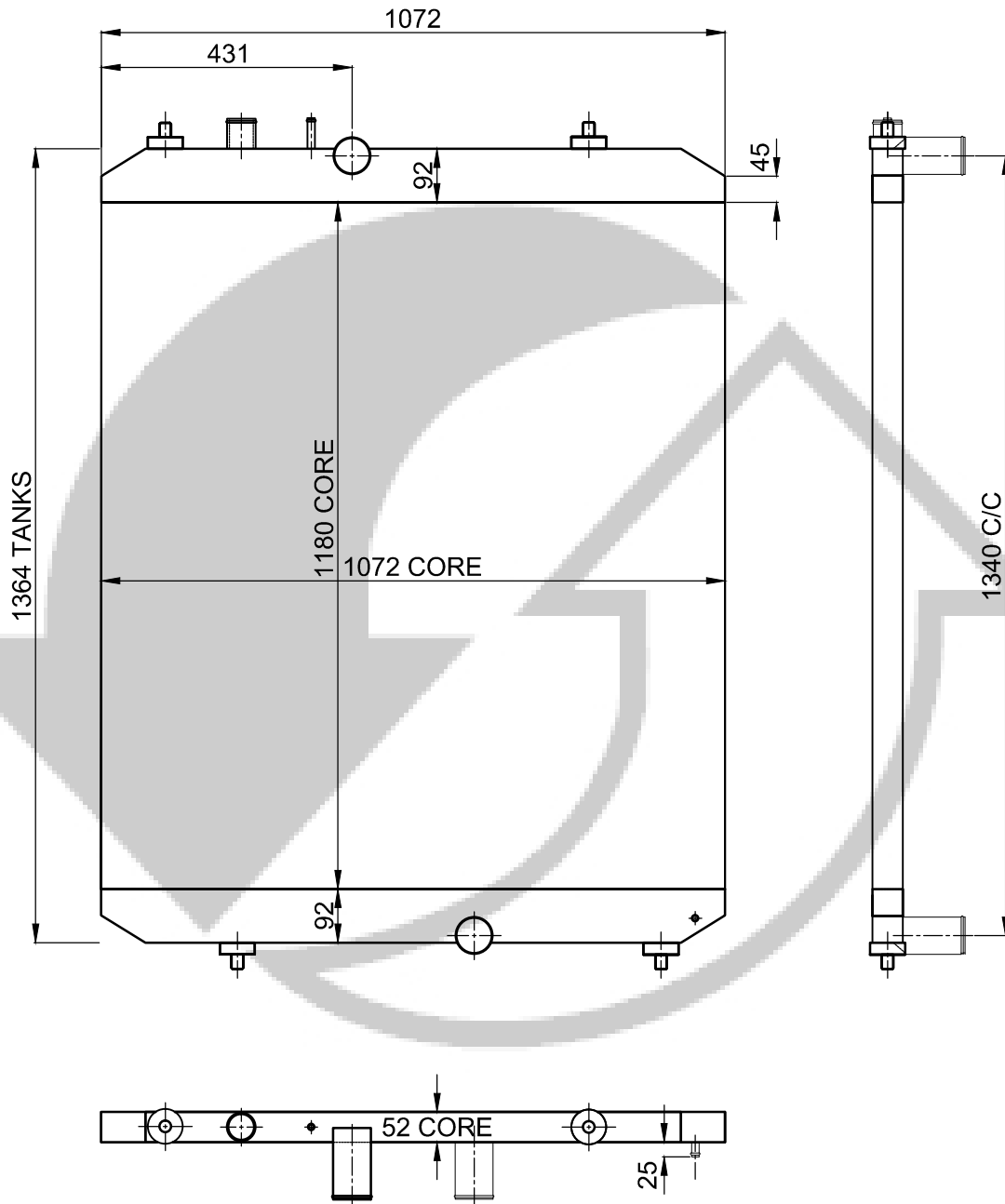

ALSO AVAILABLE IN COPPER



MODEL:VOLVO PENTA TAD1641GE

PART NUMBER:RAD1180VOL1COM

RADIATOR-VOLVO

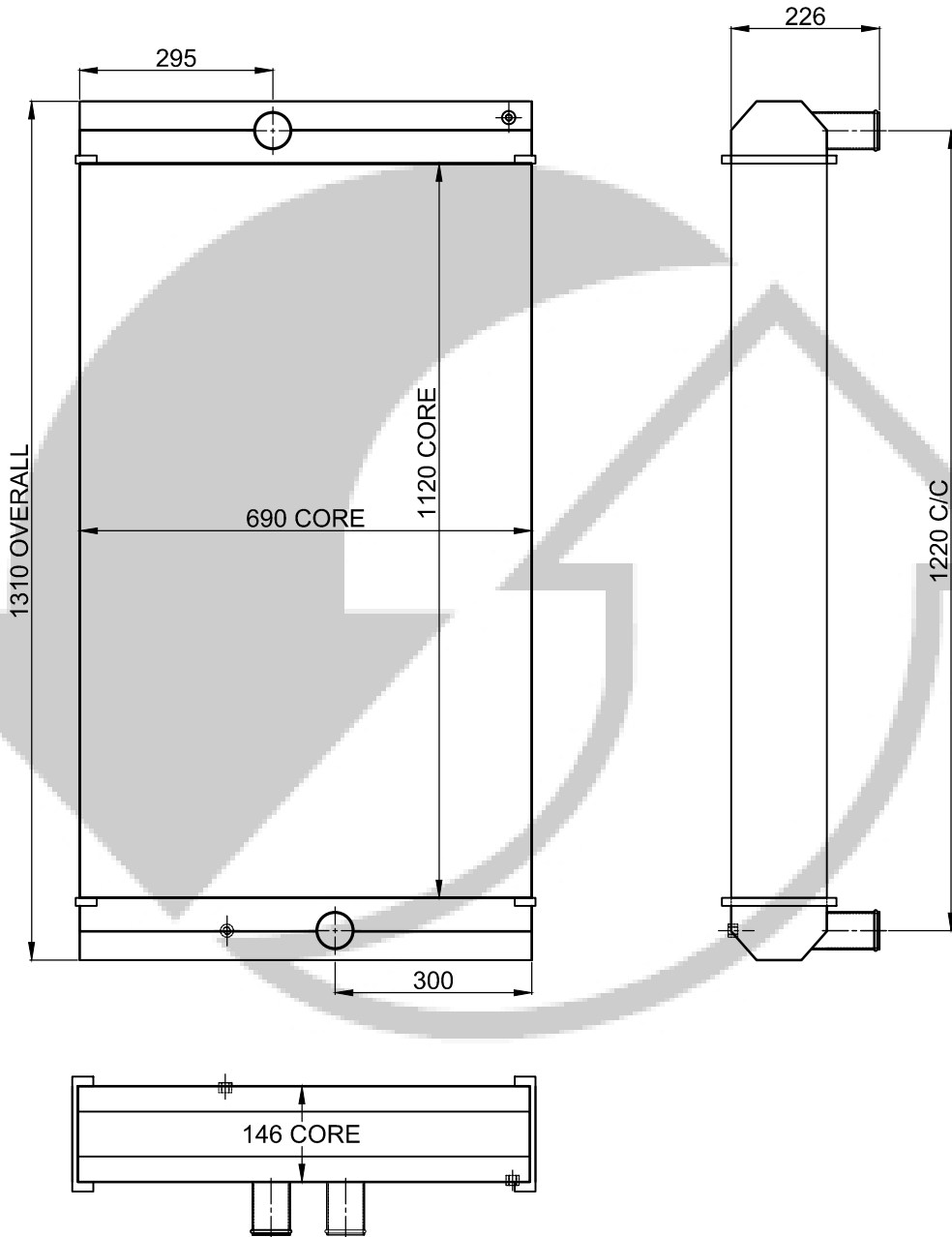

MODEL:VOLVO EC750

PART NUMBER:RAD1120VOL1COM

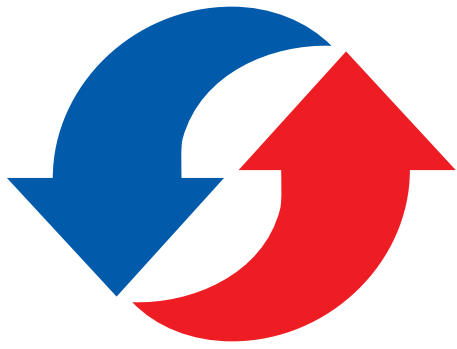

CHE

HEAT TRANSFER PRODUCTS

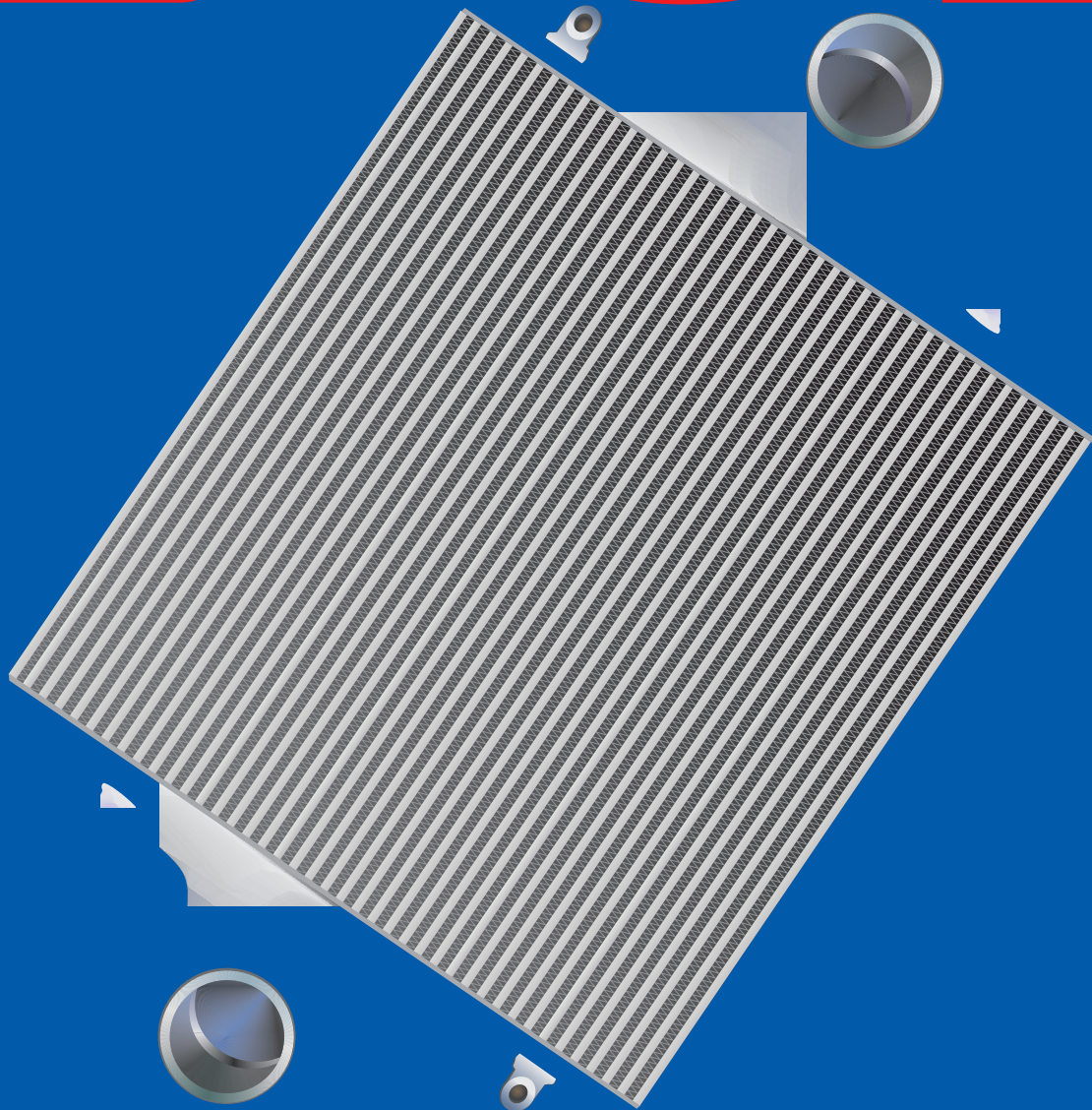

INTERCOOLERS

www.CHE.co.za

INTERCOOLER-BELL

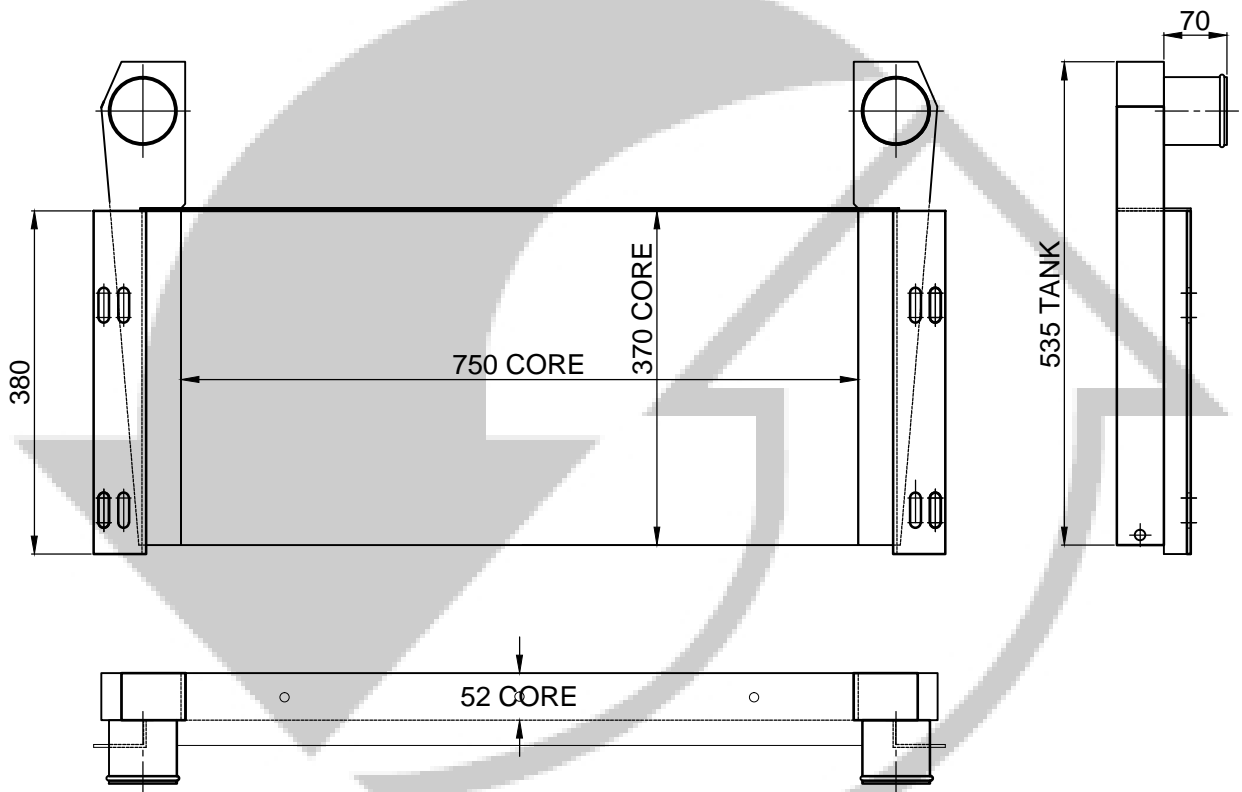

MODEL: BELL_KARMAZON

PART NUMBER: INT750BEL1COM

INTERCOOLER-FORD

Cape Heat Exchange is proud to announce the newly developed aluminium **Ford Fiesta ST Intercooler**. The intercooler was developed with performance optimization in mind. The newly developed unit maximises the available space thus improving the overall charge air characteristics. It is a tube and bar system and consists of an 8 row extruded tube and fin core. The tubes are thick walled extrusions and different to the OEM and aftermarket intercooler, this intercooler is entirely made of aluminium with no plastic tanks. The aluminium tanks are similar in weight to the plastic tanks, so there are no weight penalties and will increase both the strength and durability of the complete intercooler.

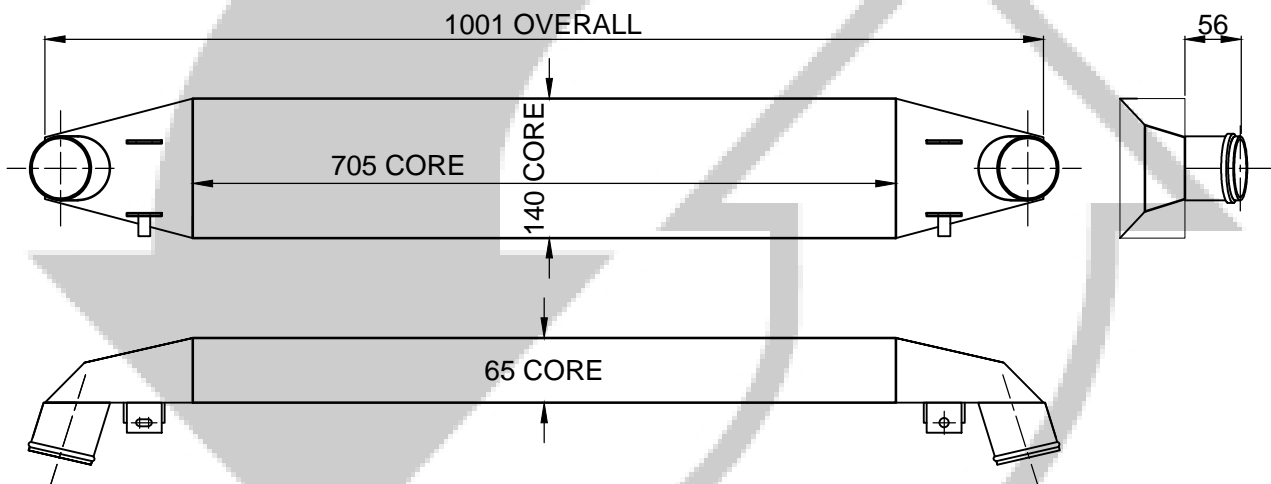

MODEL:FORD FIESTA ST

PART NUMBER:INT705FOR1COM

INTERCOOLER-FORD

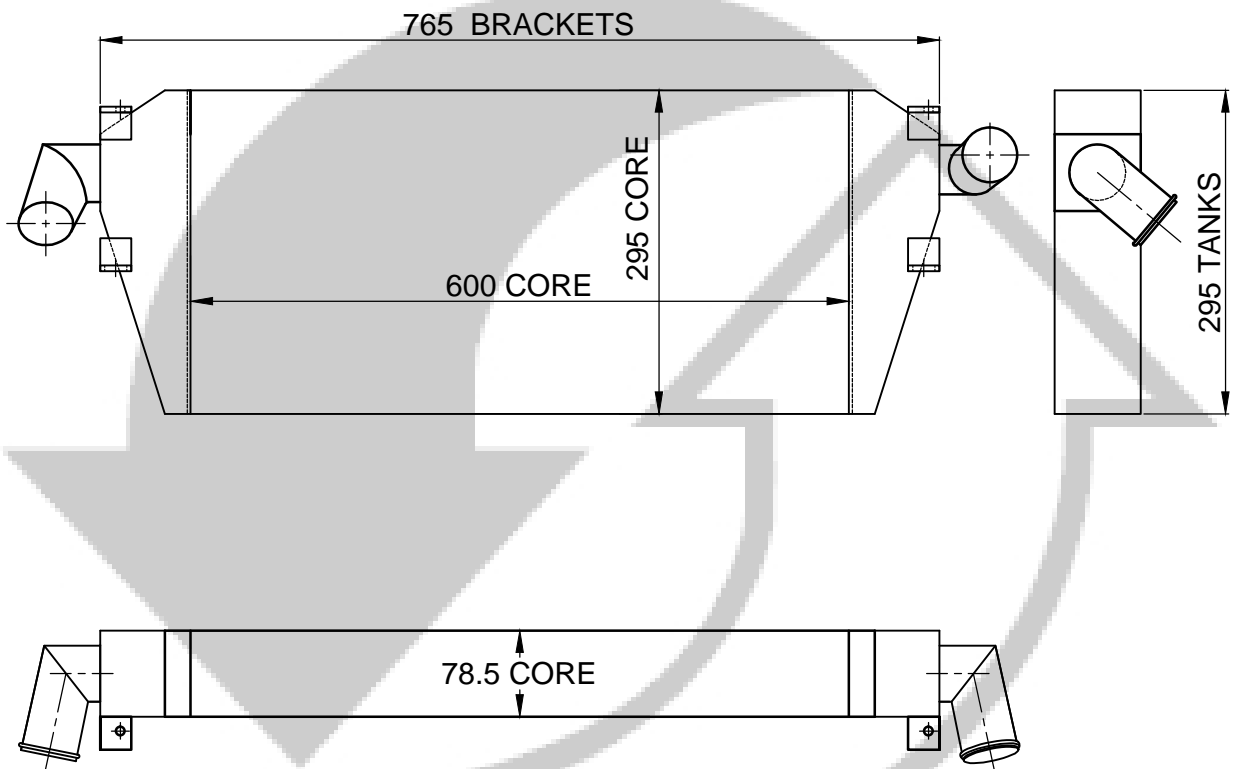

MODEL:FORD FOCUS ST

PART NUMBER:INT600FOR1COM

INTERCOOLER-FORD

The Ford Ranger is engineered to be tough, but what if it isn't tough enough for you? CHE has the solution for a stronger and more durable intercooler. The Intercooler is developed with the tough South African conditions in mind.

Our newly developed intercooler makes use of a tube and bar system, each tube are thick walled extrusions. The aluminium tanks has more strength and is similar in weight to the plastic tanks. The tanks are directly welded on to the core which minimises the possibilities for future leakages.

The CHE team are confident that this intercooler is a strong and durable alternative to the OEM intercoolers on the market and we are sure that you will be able to tackle tough terrains with more confidence with this intercooler.

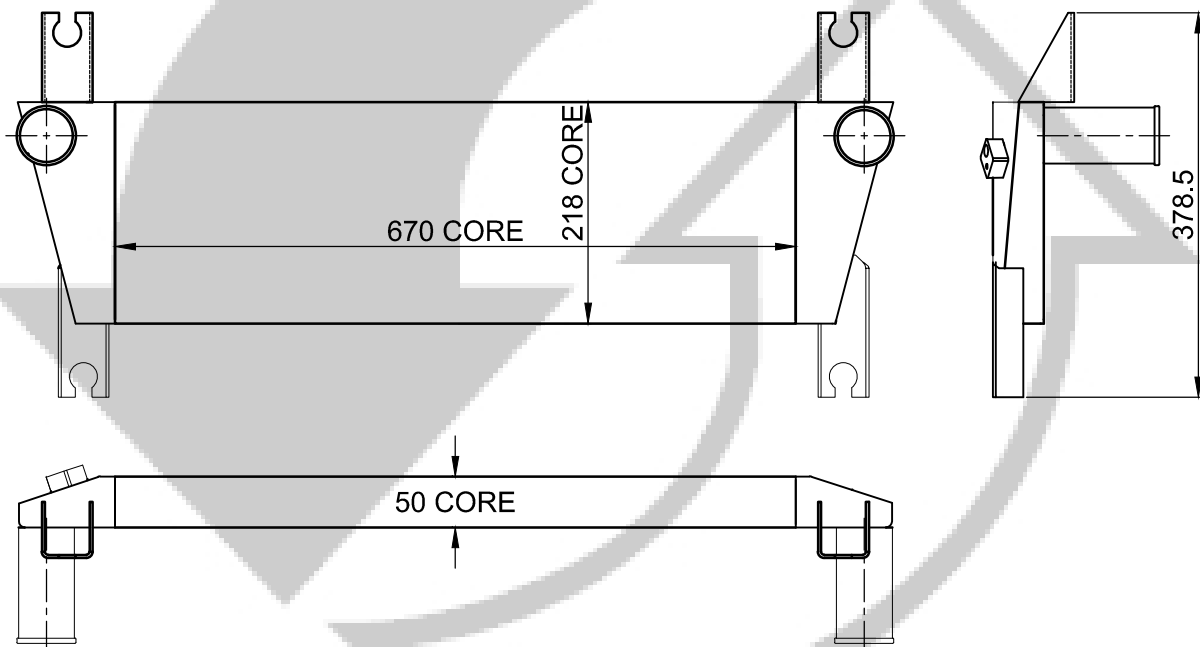

MODEL:FORD RANGER 3.2 AND 2.2

PART NUMBER:INT670FOR1COM

INTERCOOLER-ISUZU

Cape Heat Exchange is proud to announce the locally developed aluminium *Isuzu KB300 Intercooler*. The intercooler was developed with durability and South African temperature conditions in mind. The newly developed unit maximises the available space thus improving the overall charge air capabilities and ensuring sufficient cooling in a country where temperature conditions and workloads on vehicles can at times be extremely harsh. It is a tube and bar system and consists of a 15 row extruded tube and fin core. The tubes are thick walled extrusions and will ensure increased strength and durability of the intercooler.

Also available is an imported version of the *Isuzu KB300 Intercooler*, this unit is a lower priced version. There are only a batch of these units available and as we are not the manufacturers of these units we do not give any warranty on them whereas our locally produced units come with a 12 month warranty.

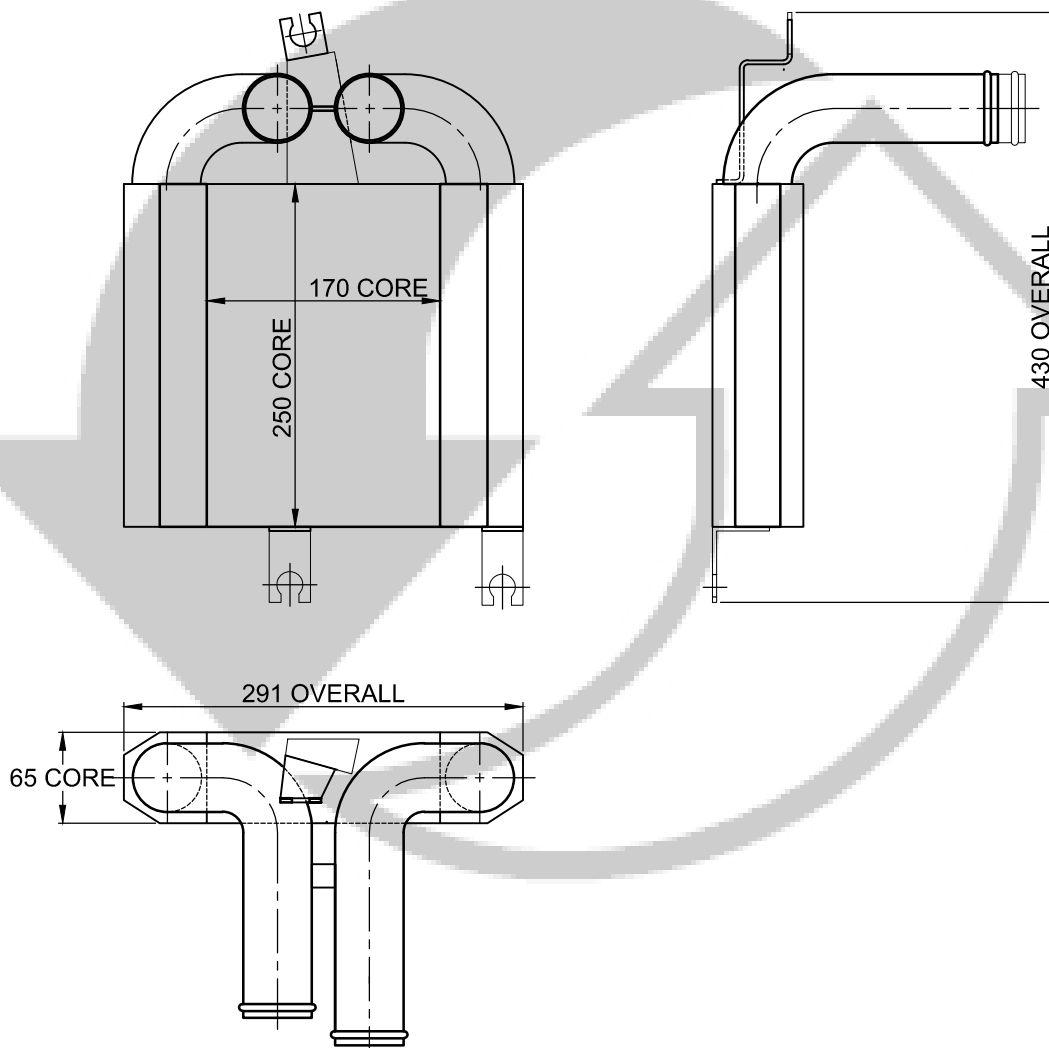

MODEL:ISUZU KB300

PART NUMBER:INT170ISU1COM

INTERCOOLER-ISUZU

Isuzu, a brand known as the pioneer in diesel engine technology. The Isuzu D-TEQ engine is a good example of the brand's forward thinking, an engine that consist of a high pressure common rail fuel injection system which produces between 1600 and 2000 bar. The result is lower emissions and a reduction in noise and vibration. A high performance engine like this needs optimally cooled air mixing with the fuel and that's why CHE has developed a new D-TEQ intercooler.

The intercooler is fully aluminium. It has a strong core that consists of thick walled tubes and aluminium tanks directly welded onto the core. The CHE team are confident that this intercooler will add durability to your Isuzu D-TEQ bakkie.

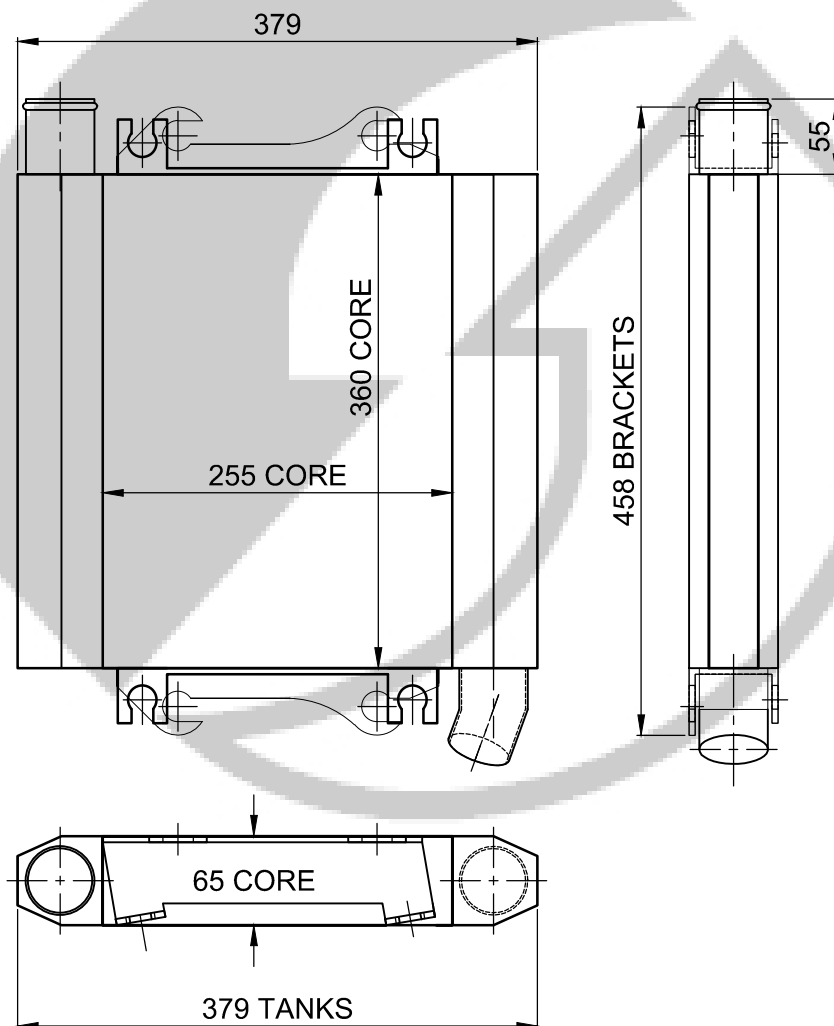

MODEL:ISUZU D-TEQ

PART NUMBER:INT255ISU1COM

INTERCOOLER-LAND ROVER

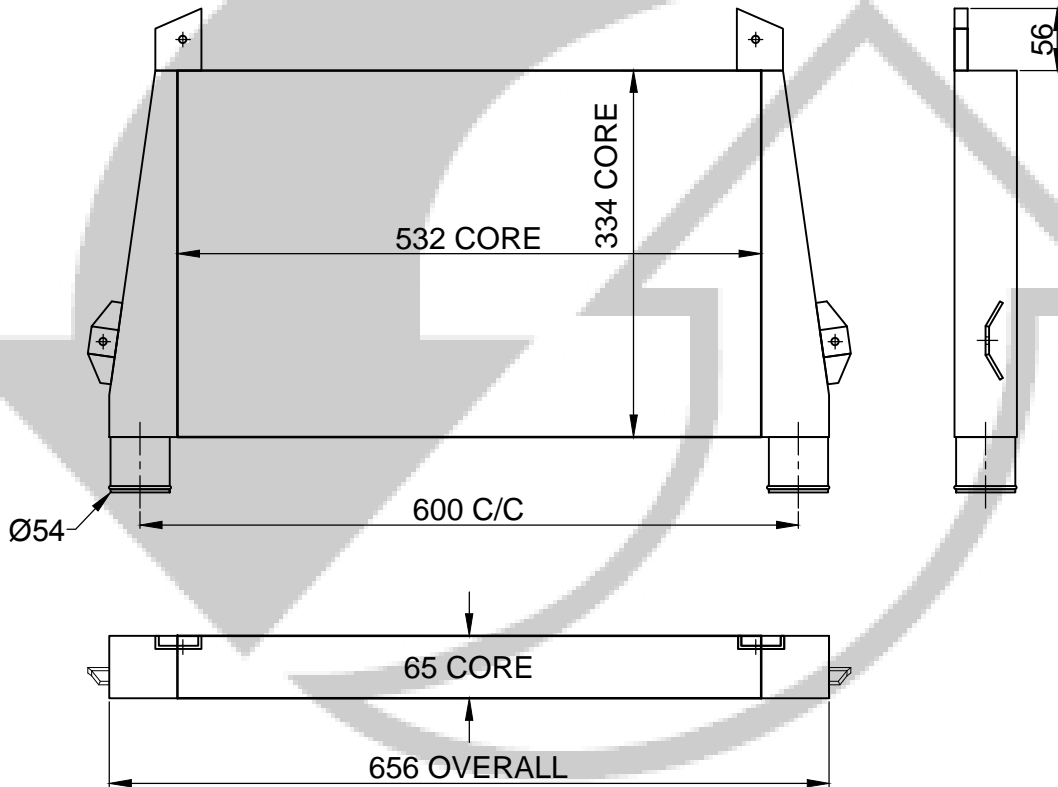

MODEL:LAND ROVER TDV6

PART NUMBER:OIL532LAN1COM

INTERCOOLER-LAND ROVER

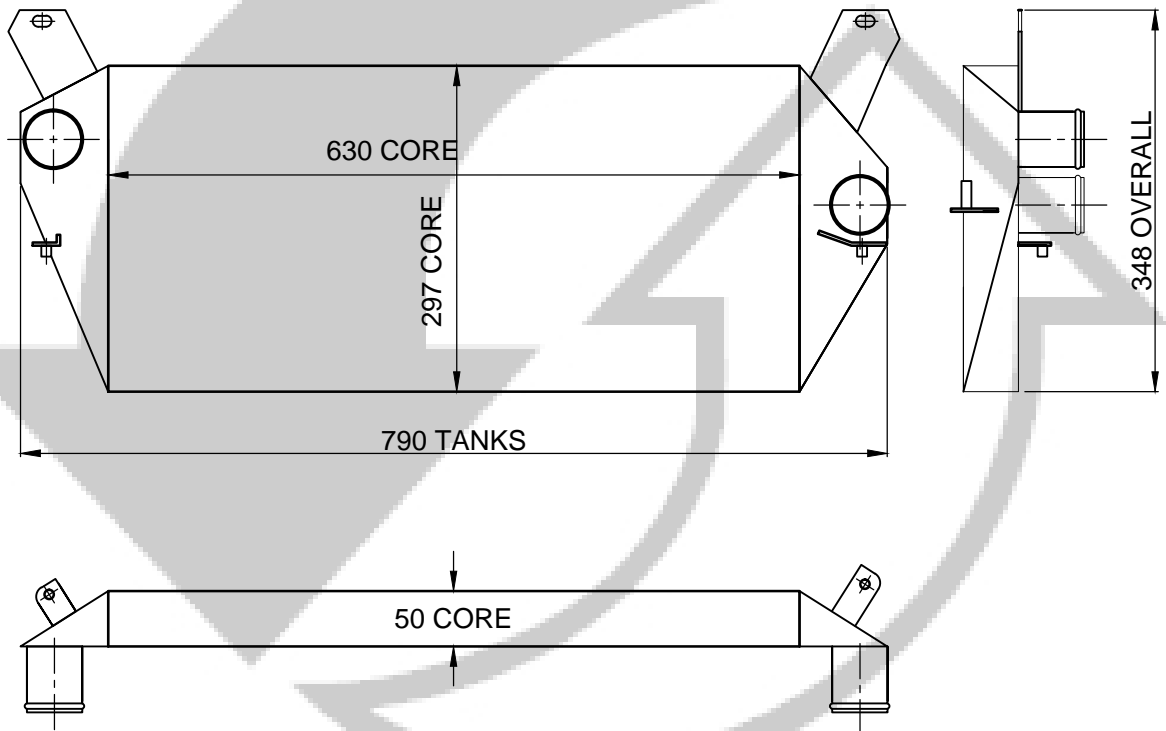

MODEL:LAND ROVER DISCOVERY TD5

PART NUMBER:INT630LAN1COM

INTERCOOLER-MAZDA

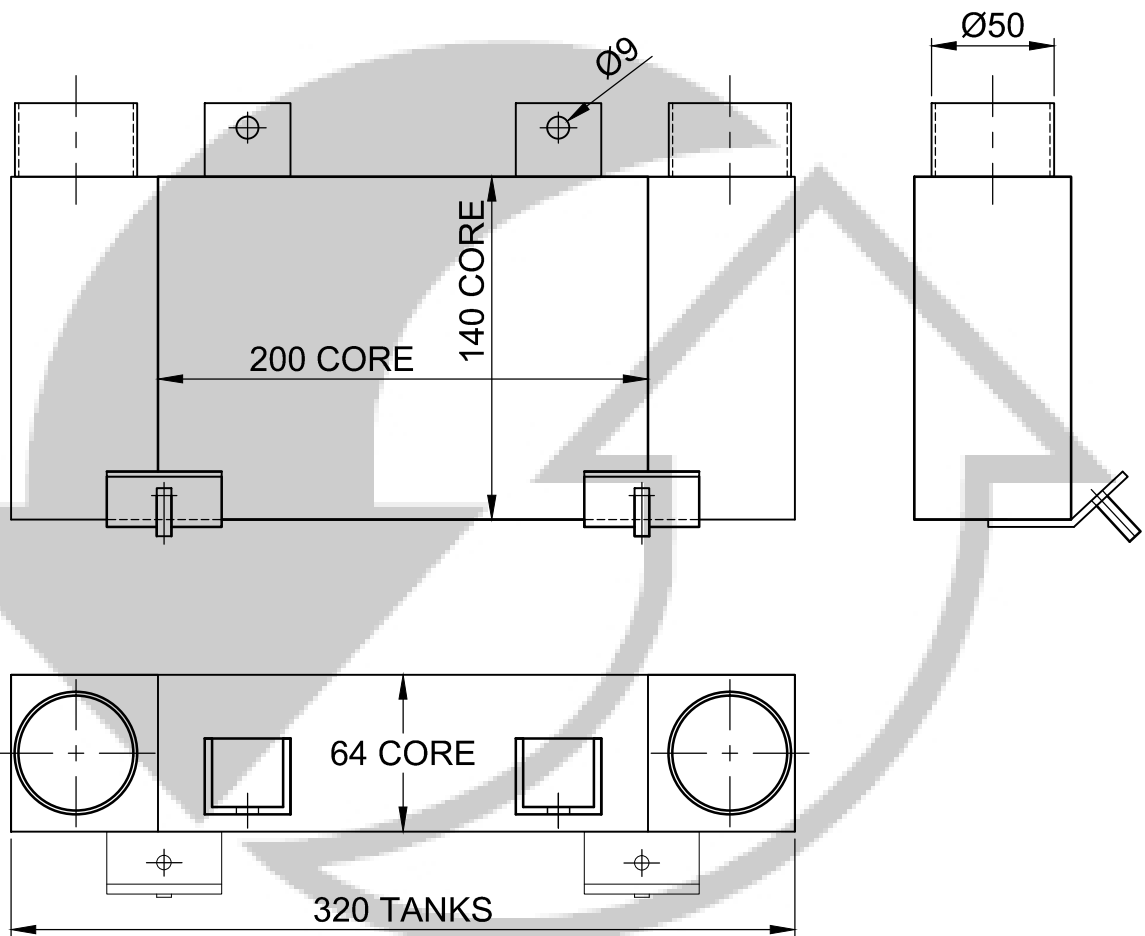

MODEL:MAZDA 2.5 DIESEL

PART NUMBER:INT200MAZ1COM

INTERCOOLER-MINI

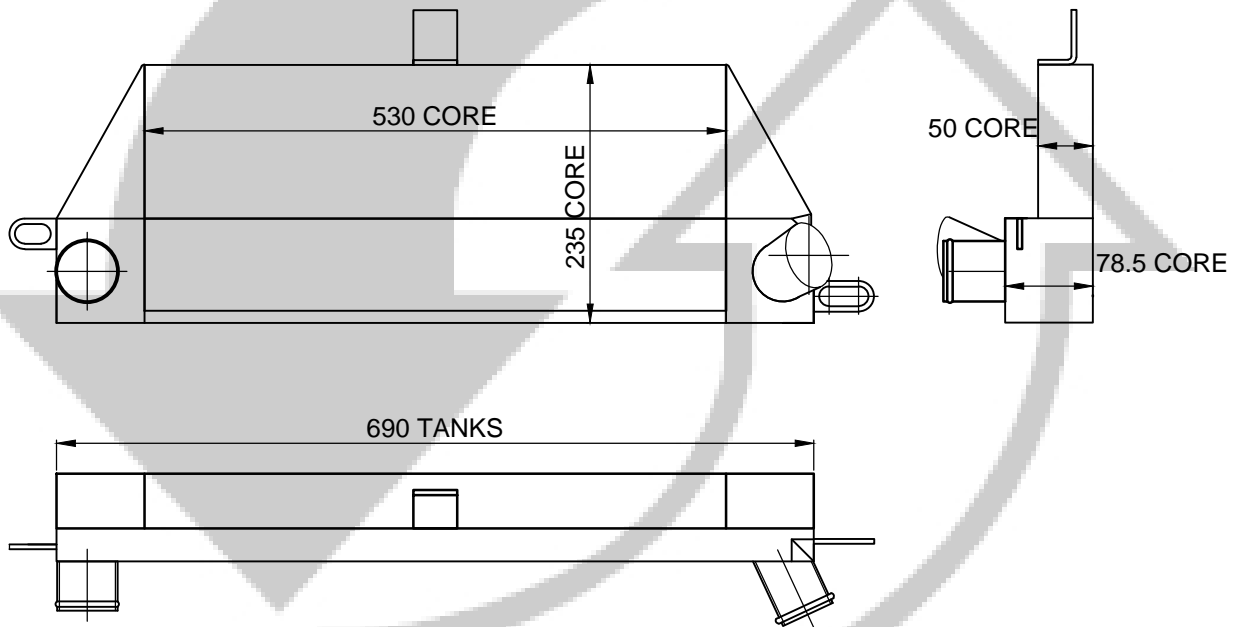

MODEL:MINI COOPER S

PART NUMBER:INT530MIN1COM

INTERCOOLER-TOYOTA

Cape Heat Exchange is proud to announce the locally developed aluminium **Hilux D4D Intercooler**. The intercooler was developed with durability and South African temperature conditions in mind. The newly developed unit maximises the available space thus improving the overall charge air capabilities and ensuring sufficient cooling in a country where temperature conditions and workloads on utility vehicles can at times be extremely harsh. It is a tube and bar system and consists of a 13 row extruded tube and fin core. The tubes are thick walled extrusions and will ensure increased strength and durability of the intercooler.

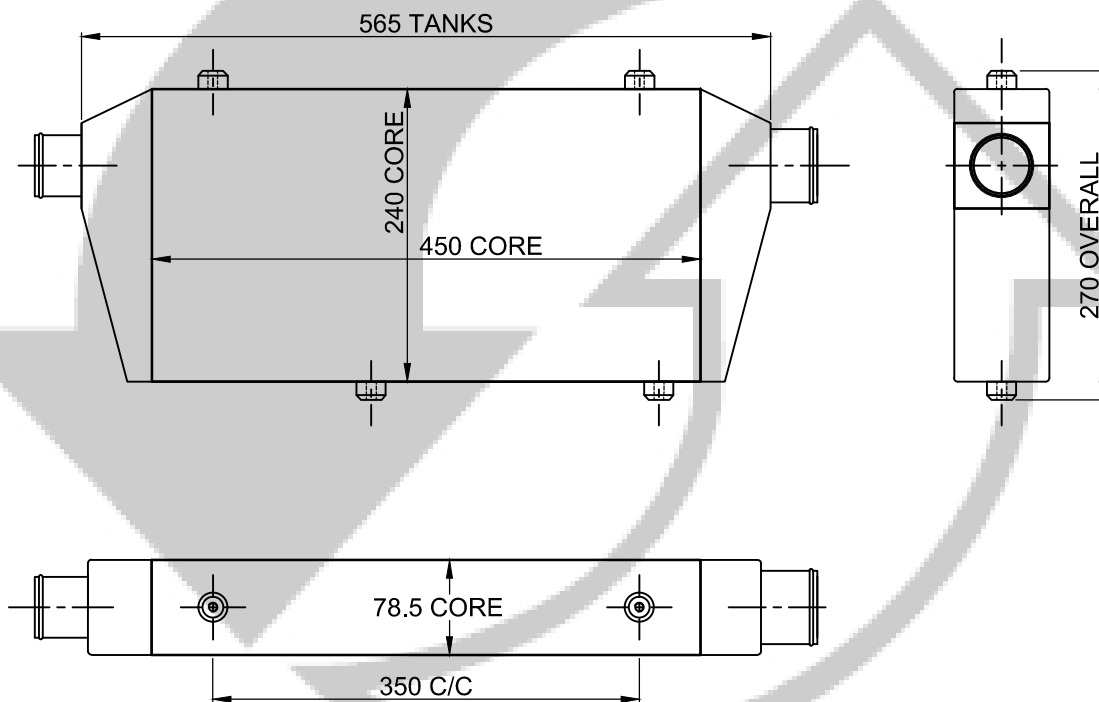

MODEL: TOYOTA HILUX D4D

PART NUMBER: INT450TOY1COM

INTERCOOLER - VOLKSWAGEN

The Volkswagen Amarok is known for being one of the more sophisticated bakkies on the market. Why can't it be the ultimate all-rounder? CHE has a solution. With our newly Developed Intercooler you will increase the durability of your Amarok 2.0 TDI, as well as your confidence to tackle tough terrains.

The intercooler is developed with tough South African conditions in mind. The aluminium tanks is directly welded on to a strong core with no header plates making future leakages less possible. The CHE team are confident that this intercooler is a strong and durable alternative to the OEM intercoolers on the market.

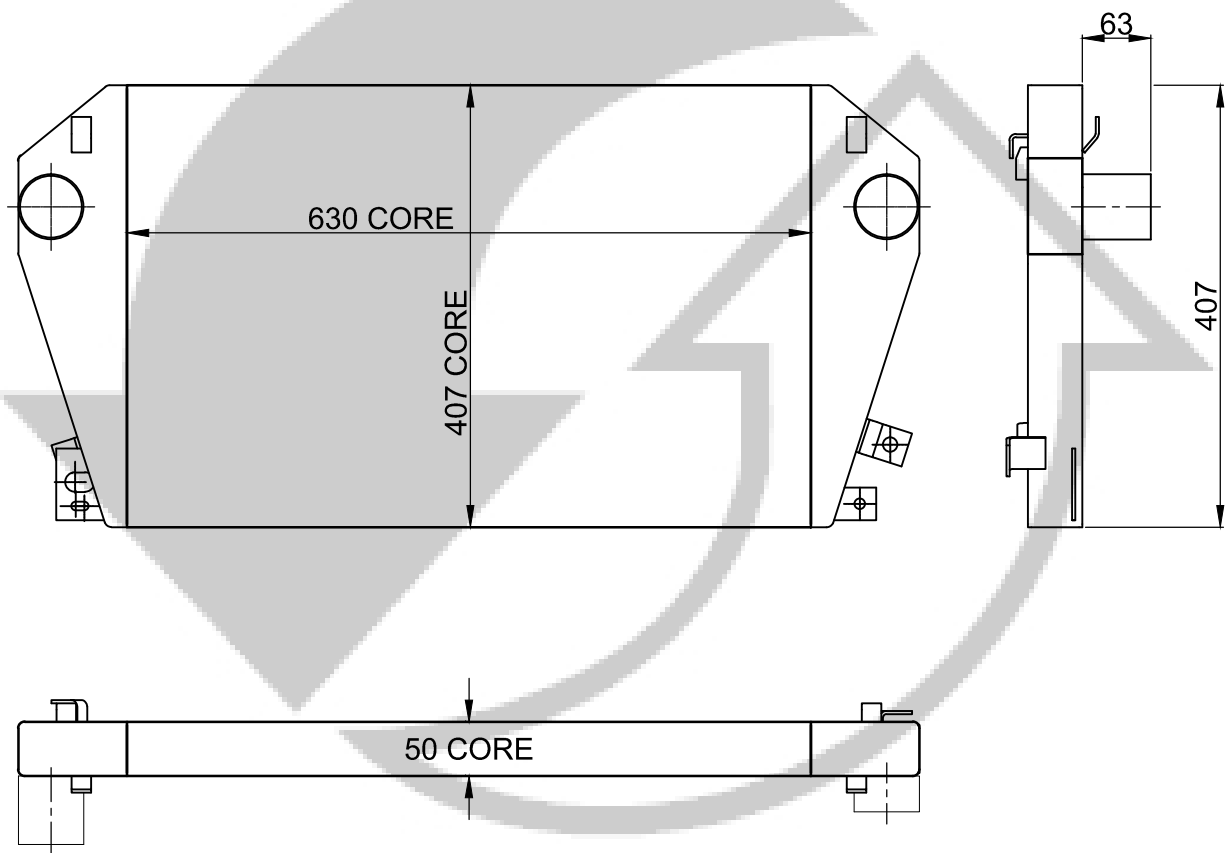

MODEL:VOLKSWAGEN AMAROK _2.0 TDI

PART NUMBER:INT630VW1COM