

# CHE

*HEAT TRANSFER PRODUCTS*

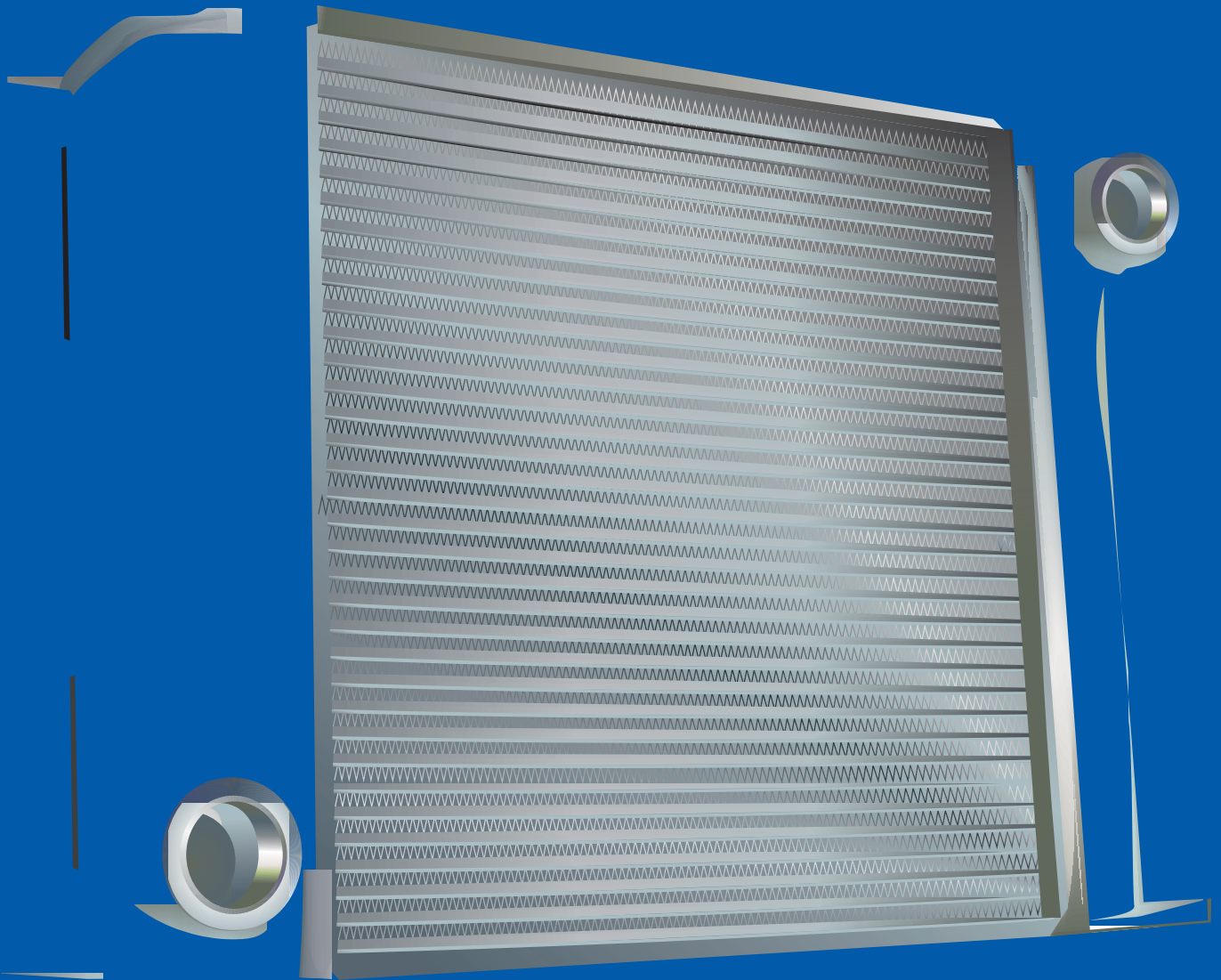

## OILCOOLERS

[www.CHE.co.za](http://www.CHE.co.za)

# CONTENTS

## OIL COOLERS

ATLAS COPCO  
BELL  
CATERPILLAR  
GALLION  
HYDROVANE  
HYUNDAI  
INGERSOL RAND  
JOHN DEERE  
LINDE  
MAGIRUS  
MAN  
MERCEDES BENZ  
NISSAN  
SB COOLER  
SCANIA  
SUZUKI  
TOYOTA  
ZIP COOLERS

## TRANSMISSION COOLERS

FORD  
HYSTER  
LAND ROVER  
MAN  
MERCEDES BENZ

# OILCOOLER-ATLAS COPCO

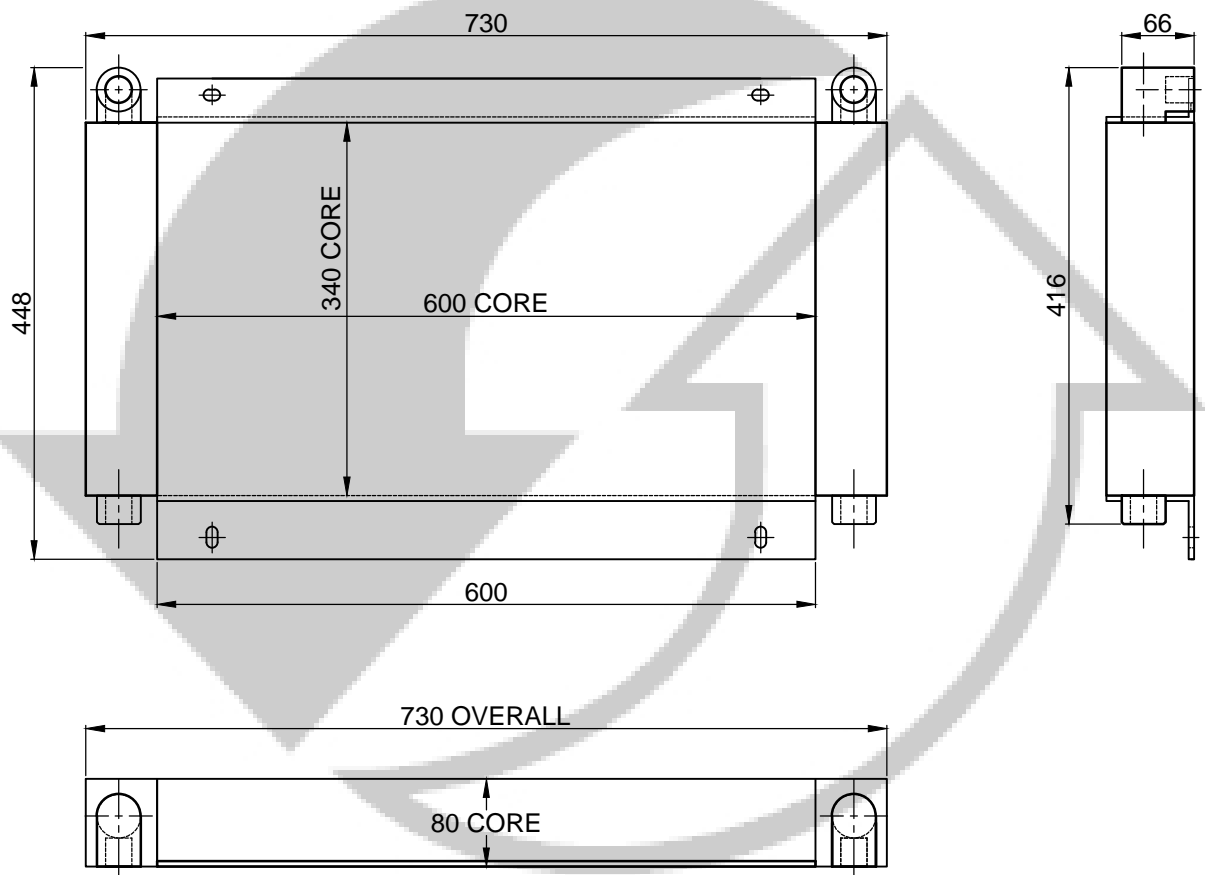

MODEL:ATLAS COPCO XA 85

PART NUMBER:OIL614ATL1COM

# OILCOOLER-ATLAS COPCO

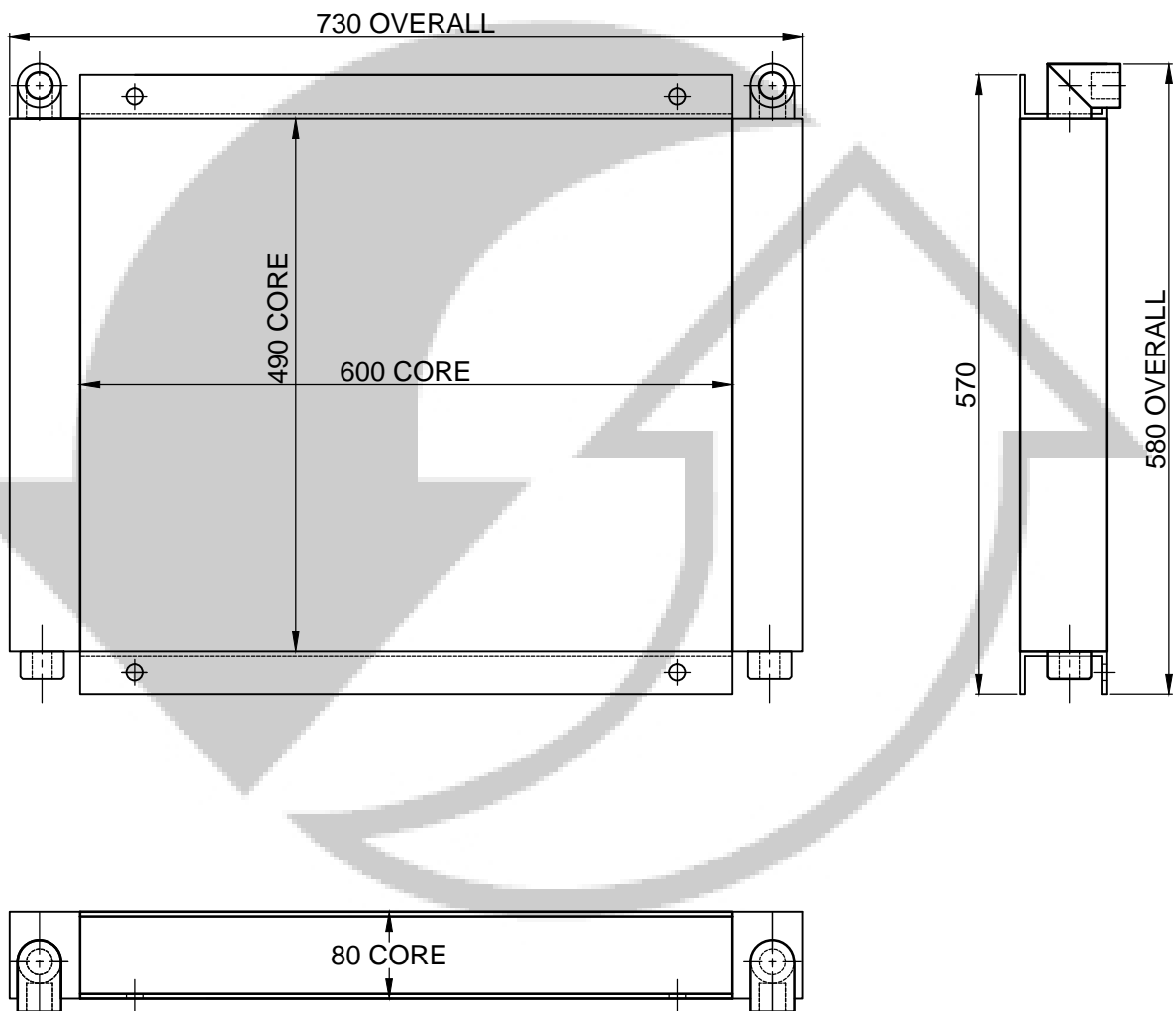

MODEL:ATLAS COPCO

PART NUMBER:OIL614ATL3COM

# OILCOOLER-ATLAS COPCO

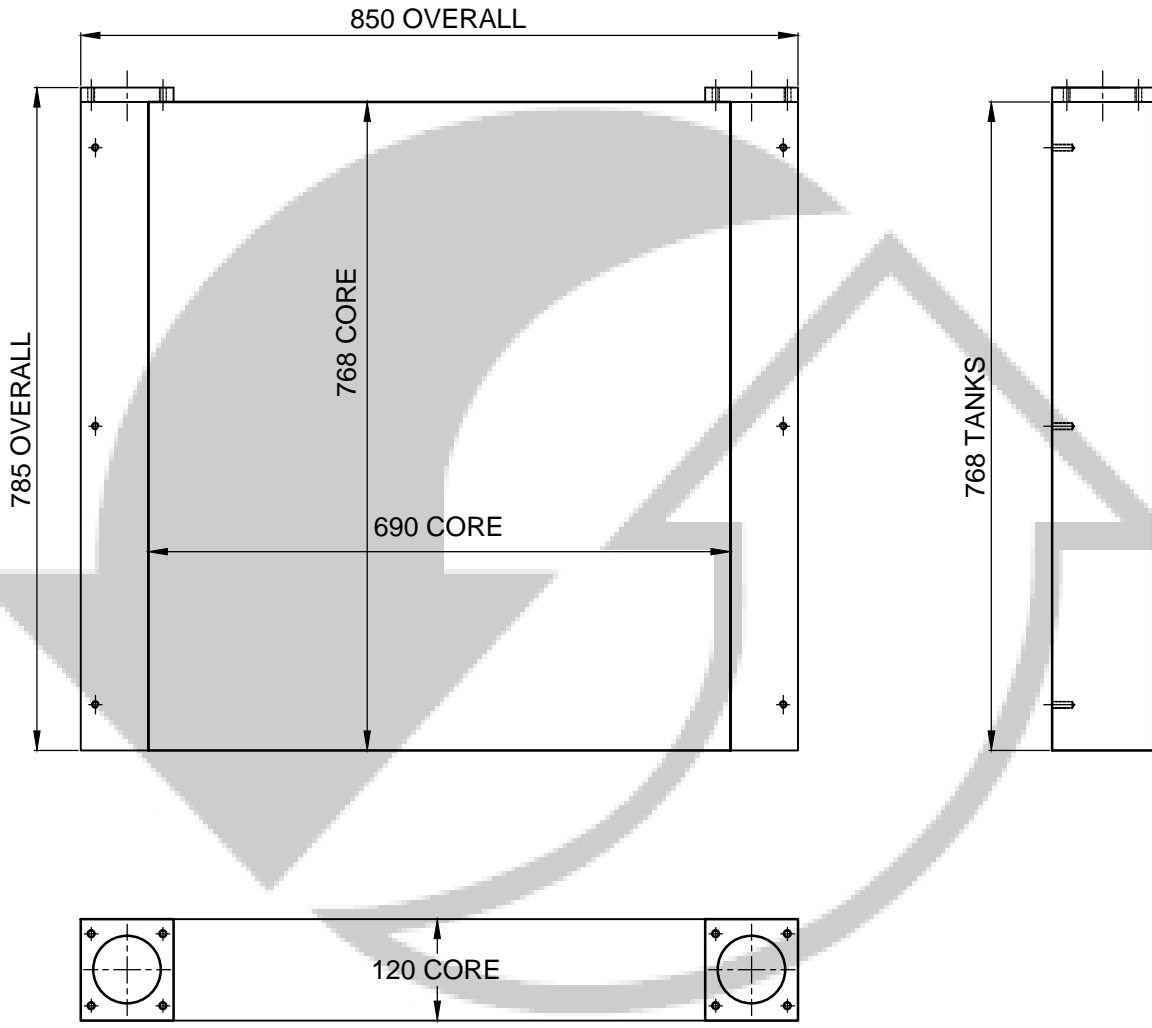

MODEL:ATLAS COPCO

PART NUMBER:OIL684ATL1COM

# OILCOOLER-BELL

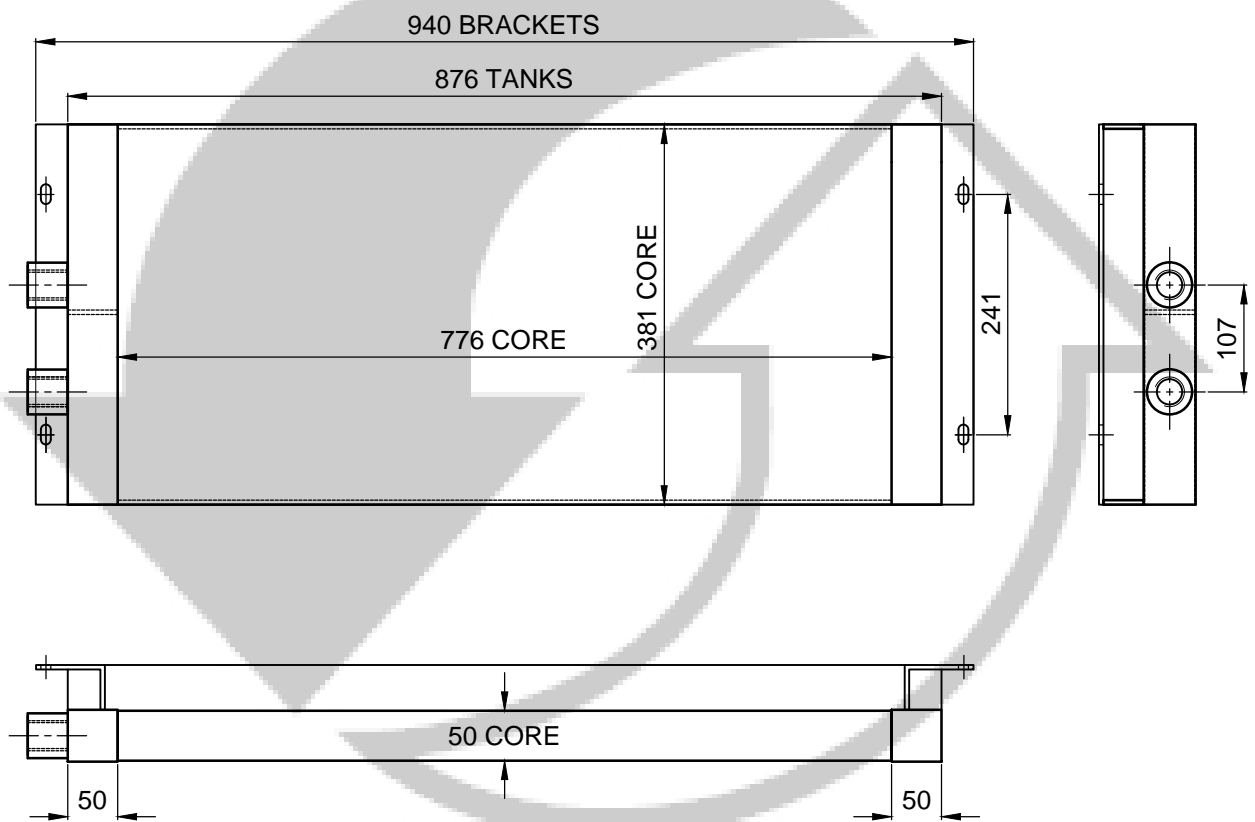

MODEL: BELL B25\_API

PART NUMBER: OIL760BEL1COM

# OILCOOLER-BELL

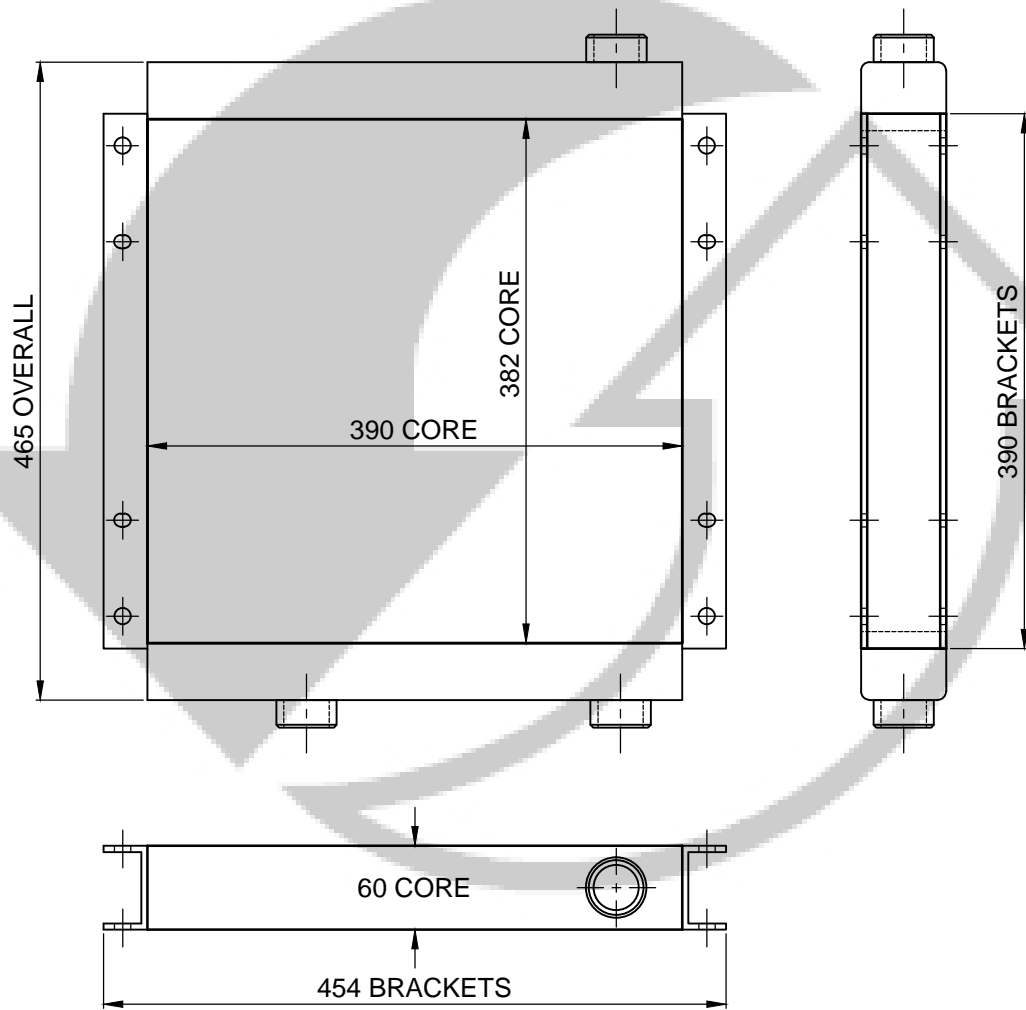

MODEL: BELL-B40

PART NUMBER: OIL390BEL1COM

# OILCOOLER-BELL

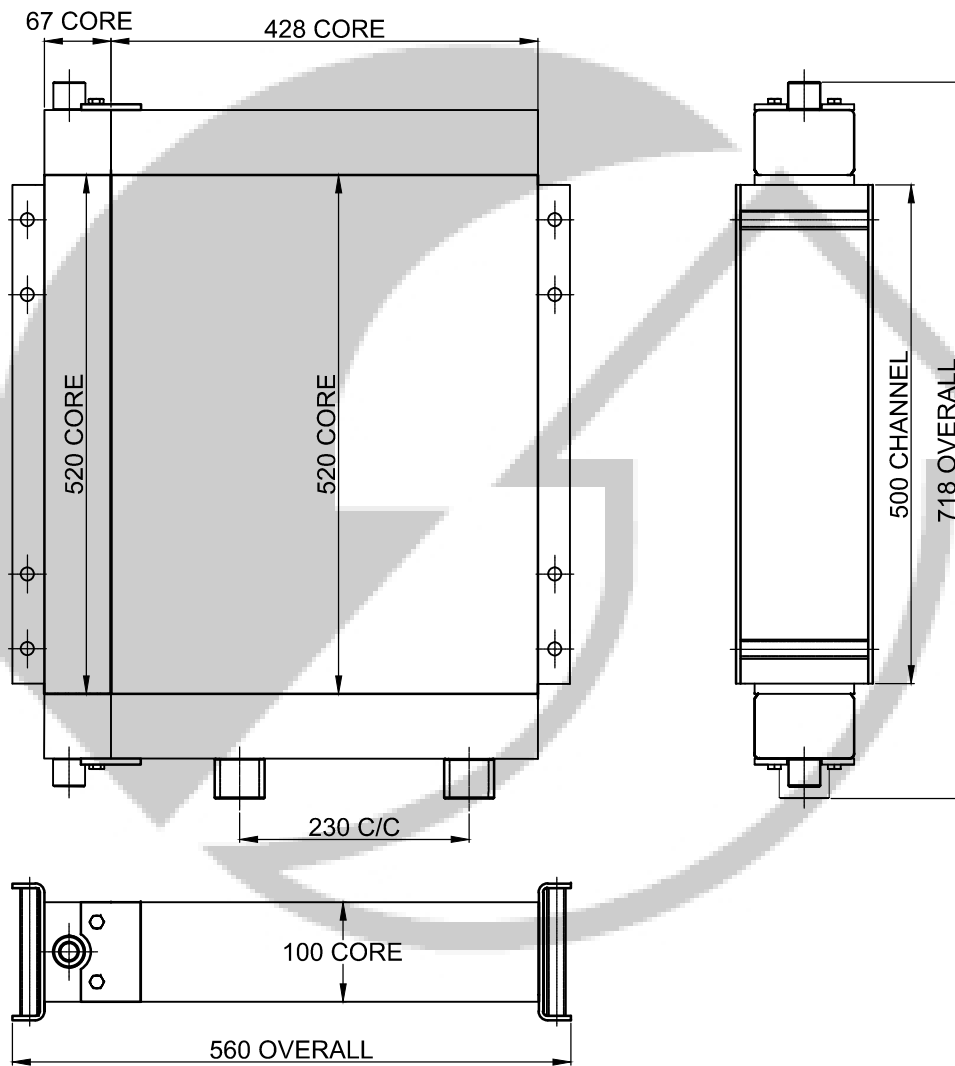

MODEL: BELL

PART NUMBER: OIL533BEL1COM



# OILCOOLER-BELL

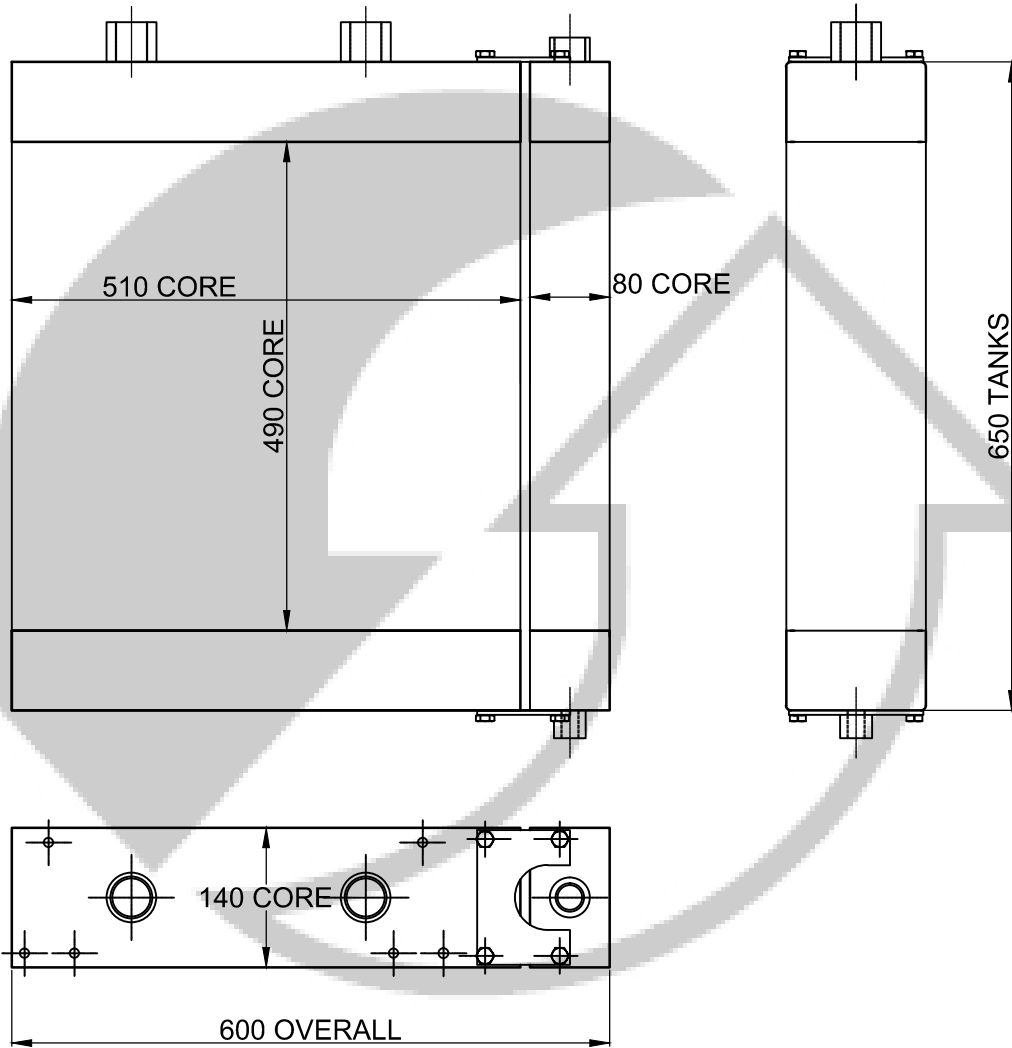

MODEL: BELL

PART NUMBER: OIL490BEL1COM

# OILCOOLER-CATERPILLAR

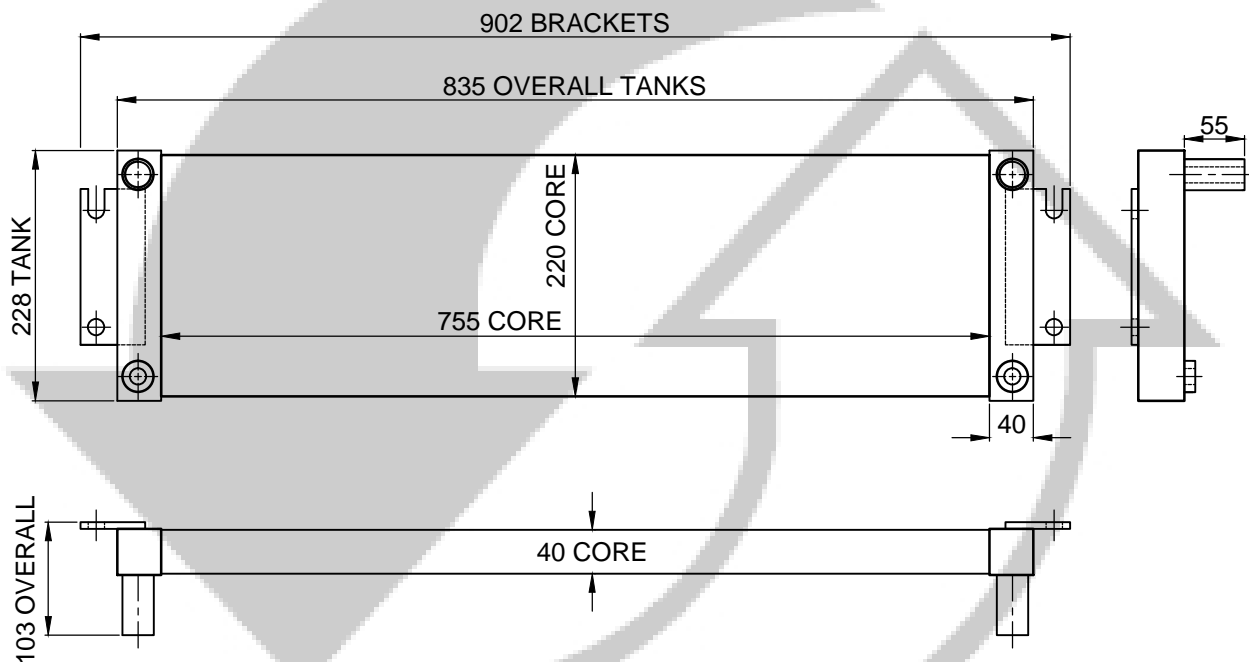

ORIGINAL UNIT IS A STEEL UNIT.



MODEL:CATERPILLAR 140G

PART NUMBER:OIL739CAT1COM

# OILCOOLER-CAT

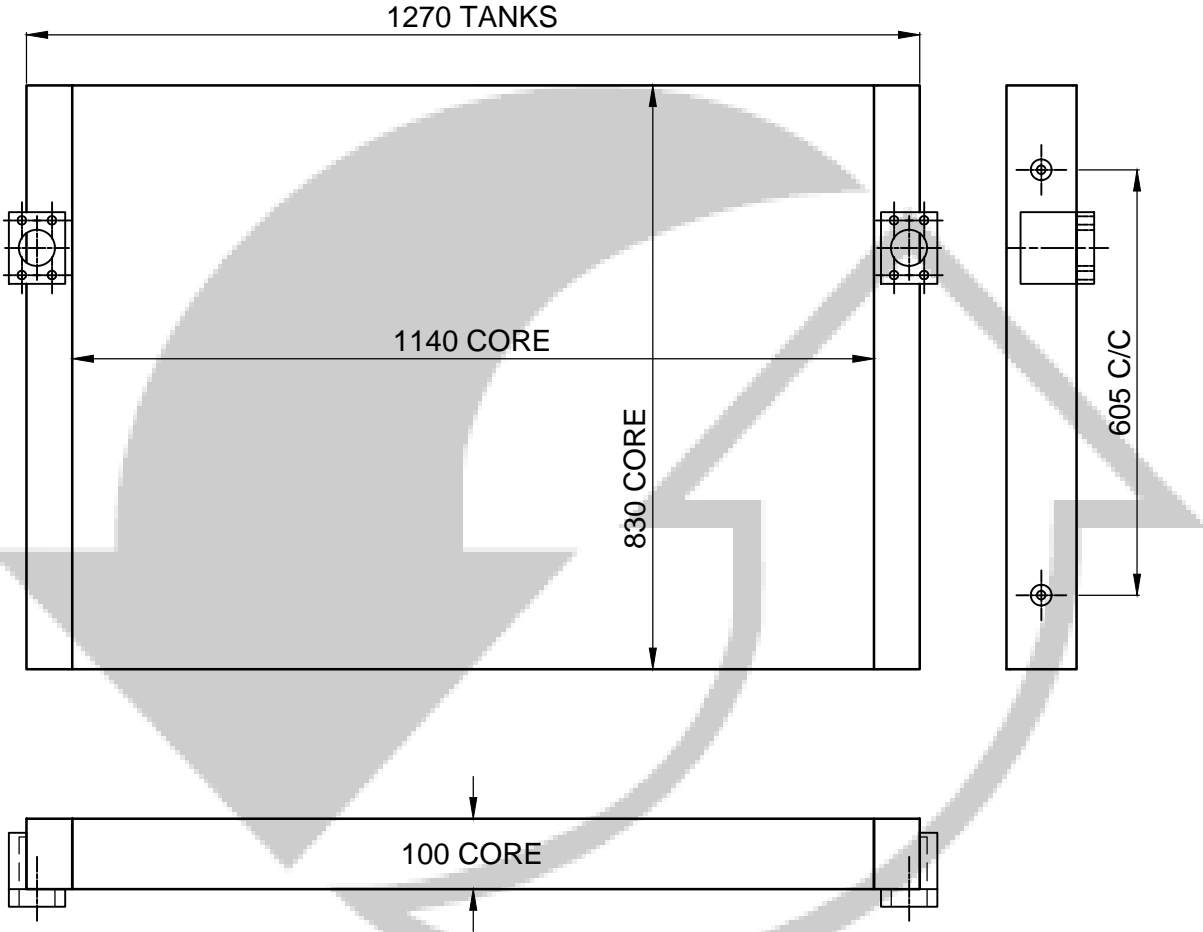

MODEL: CAT 345D EXCAVATOR

PART NUMBER: OIL1140CAT1COM

# OILCOOLER-GALLION

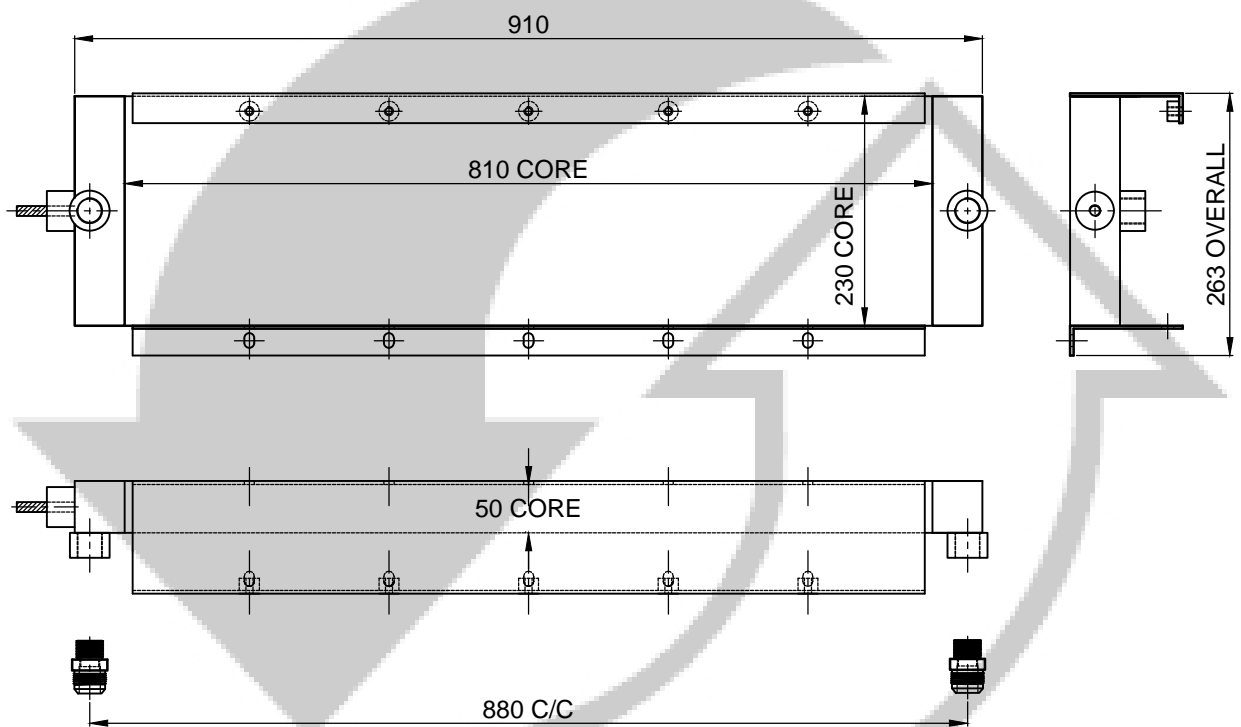

ORIGINAL UNIT IS A STEEL UNIT.



MODEL:GALLION T500/T600

PART NUMBER:OIL794GAL1COM

# OILCOOLER-HYDROVANE

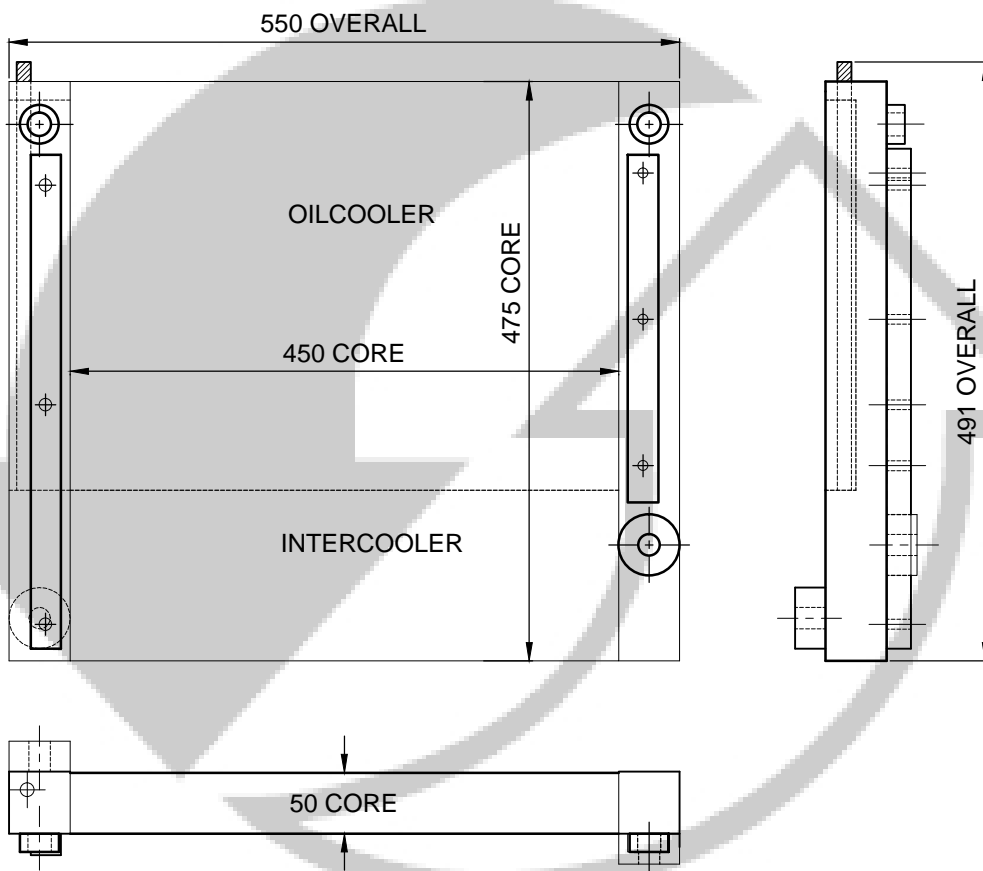

MODEL:HYDROVANE

PART NUMBER:OIL434HYD1COM

# OILCOOLER-HYDROVANE

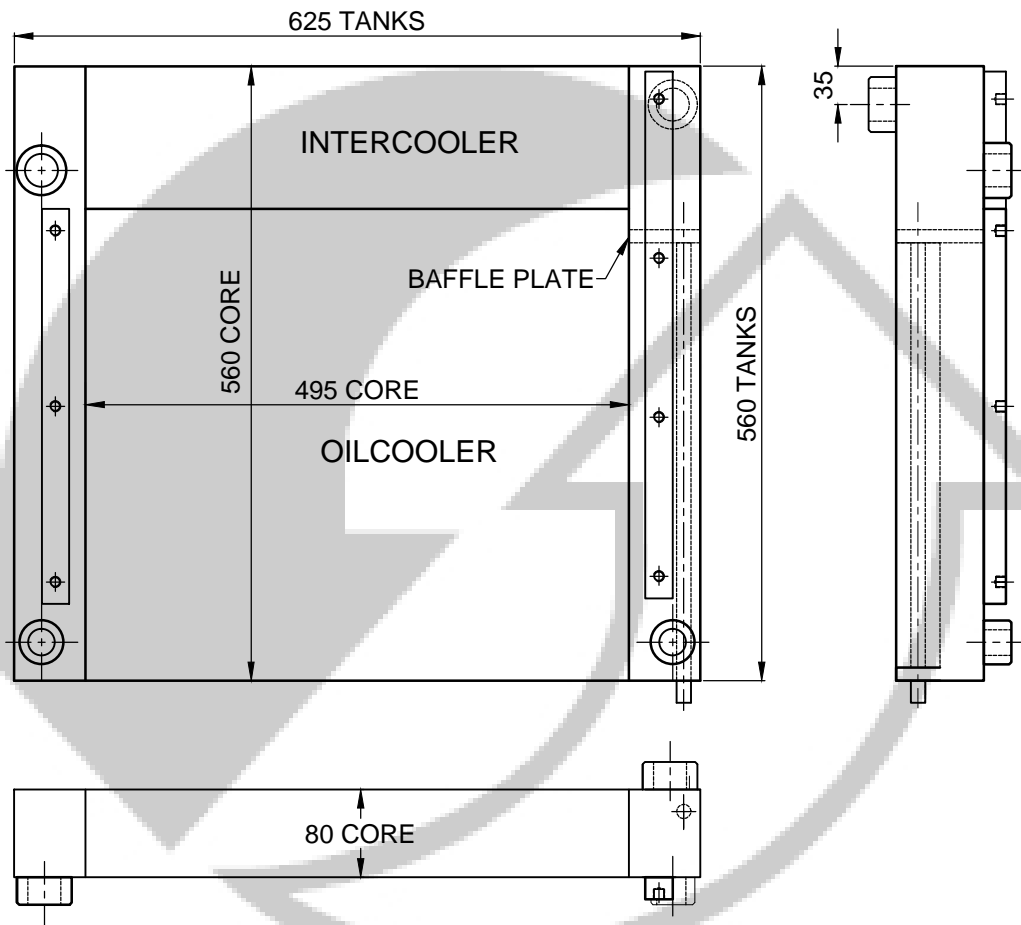

MODEL:HYDROVANE

PART NUMBER:OIL509HYD1COM

# OILCOOLER-HYDROVANE

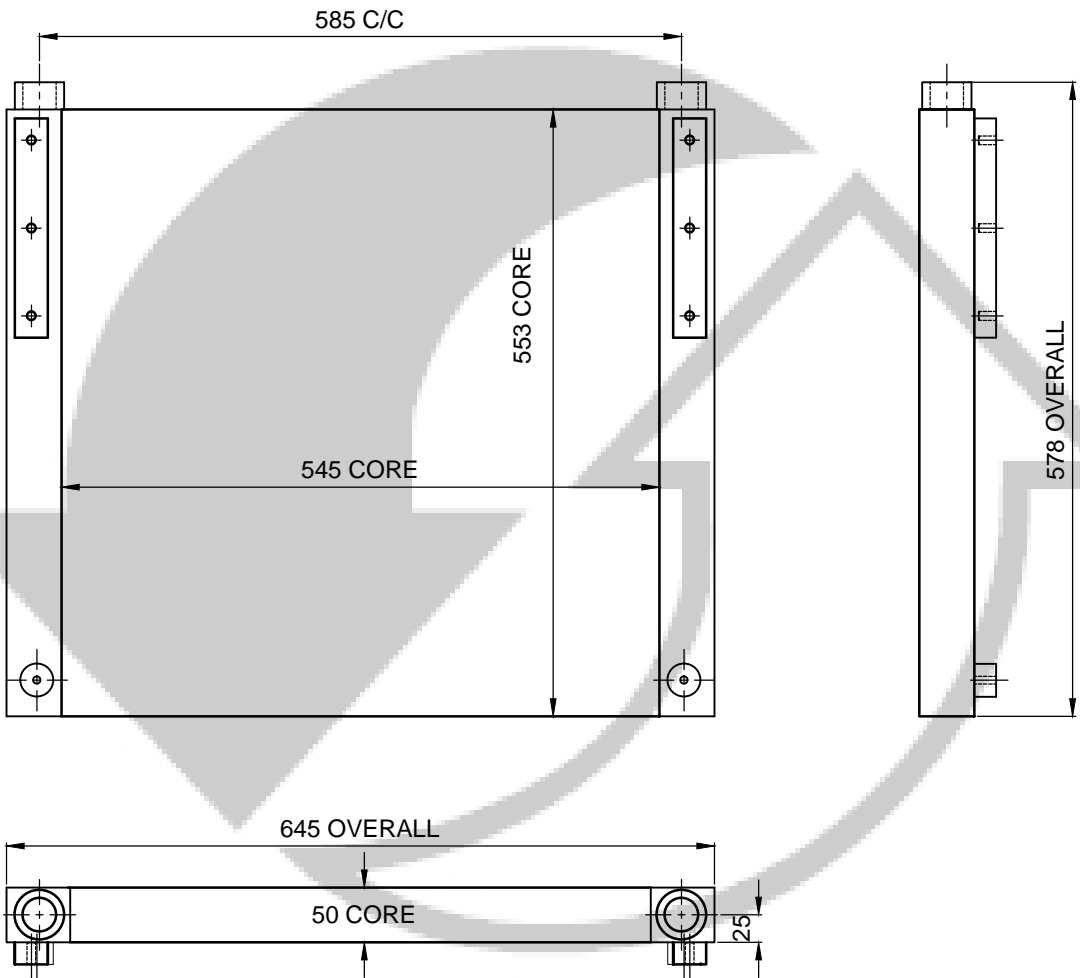

MODEL:HYDROVANE

PART NUMBER:OIL529HYD1COM

# OILCOOLER-HYDROVANE

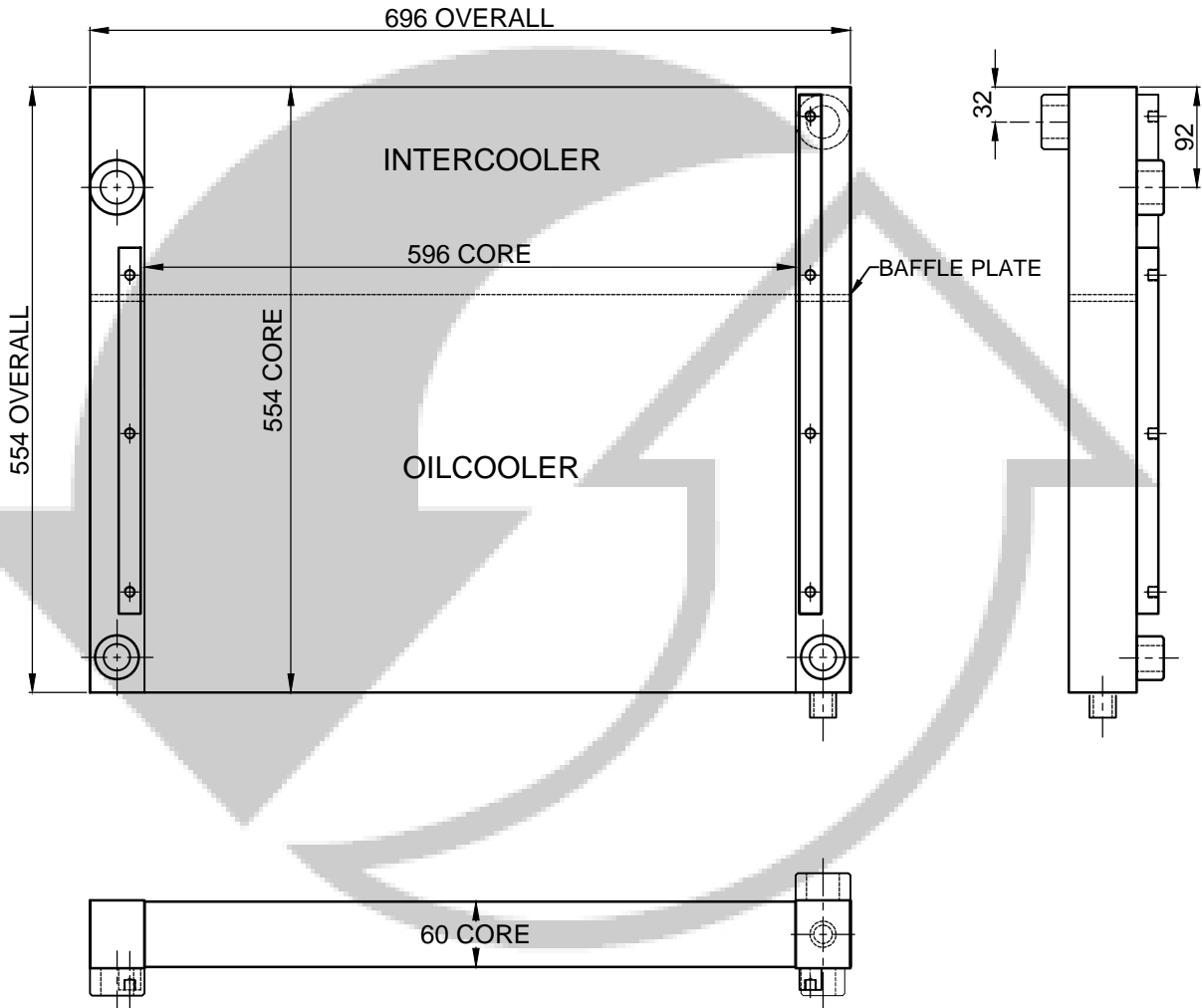

MODEL:HYDROVANE

PART NUMBER:OIL580HYD1COM



# OILCOOLER-HYDROVANE

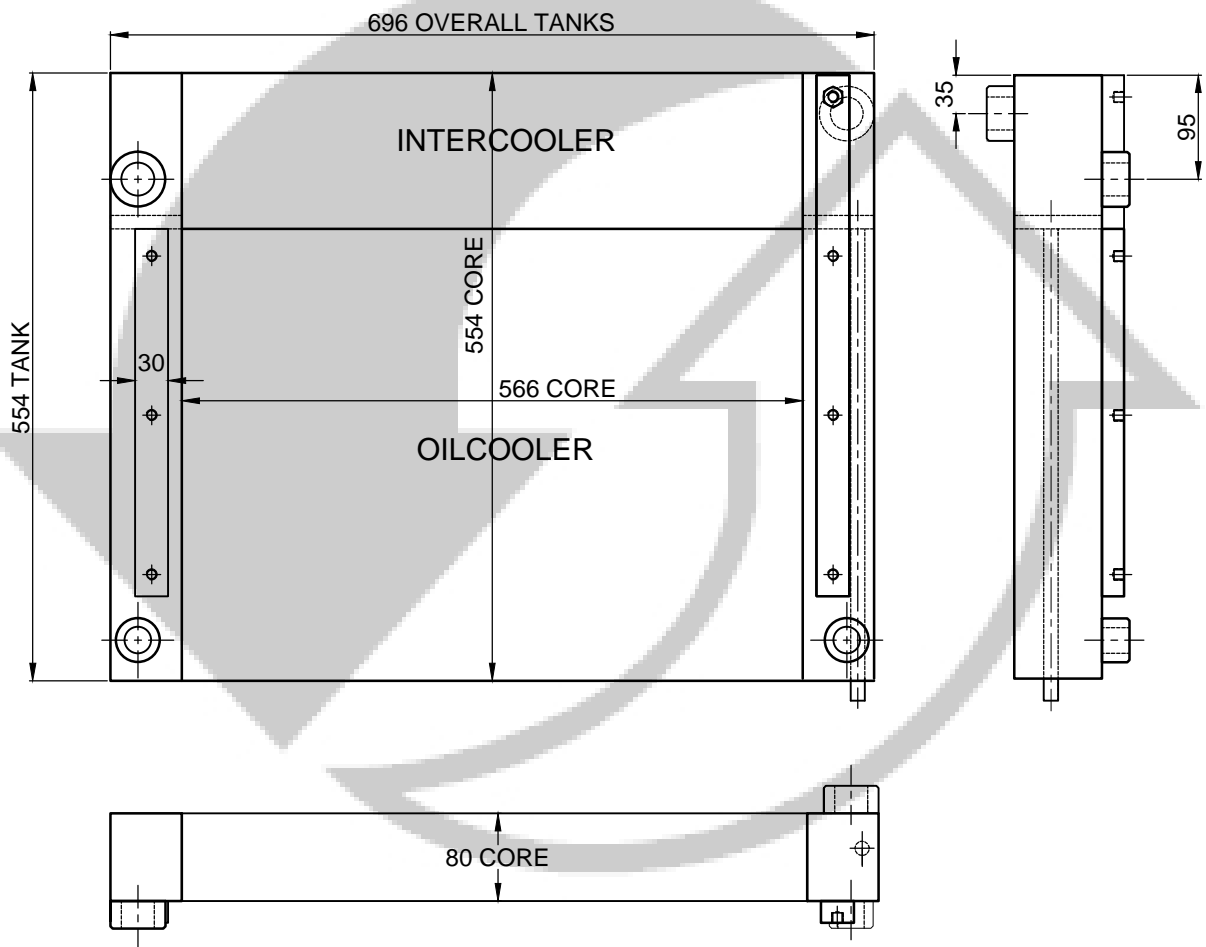

MODEL:HYDROVANE

PART NUMBER:OIL580HYD3COM

# OILCOOLER-HYDROVANE

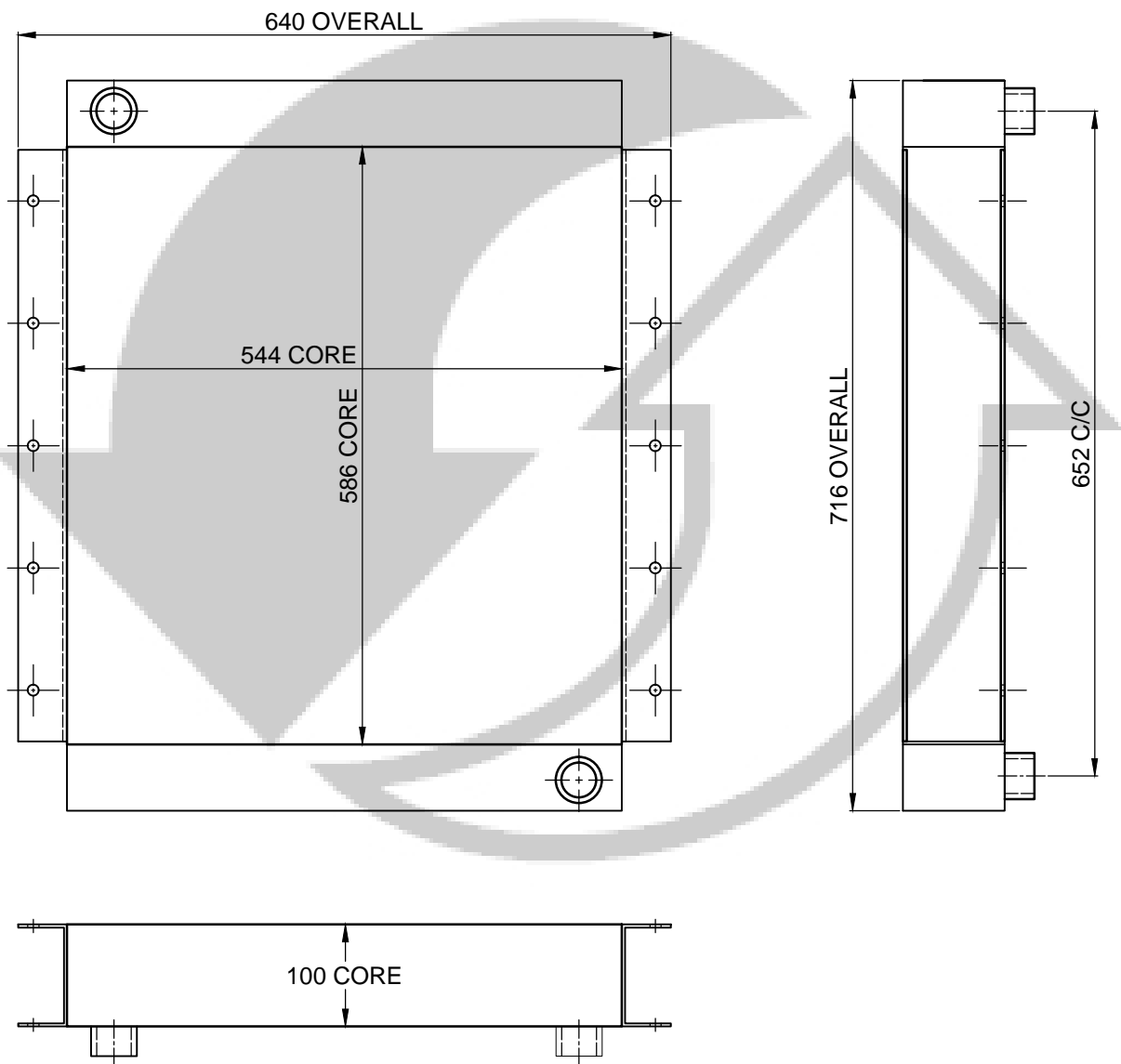

MODEL:HYDROVANE

PART NUMBER:OIL600HYD1COM

# OILCOOLER-HYDROVANE

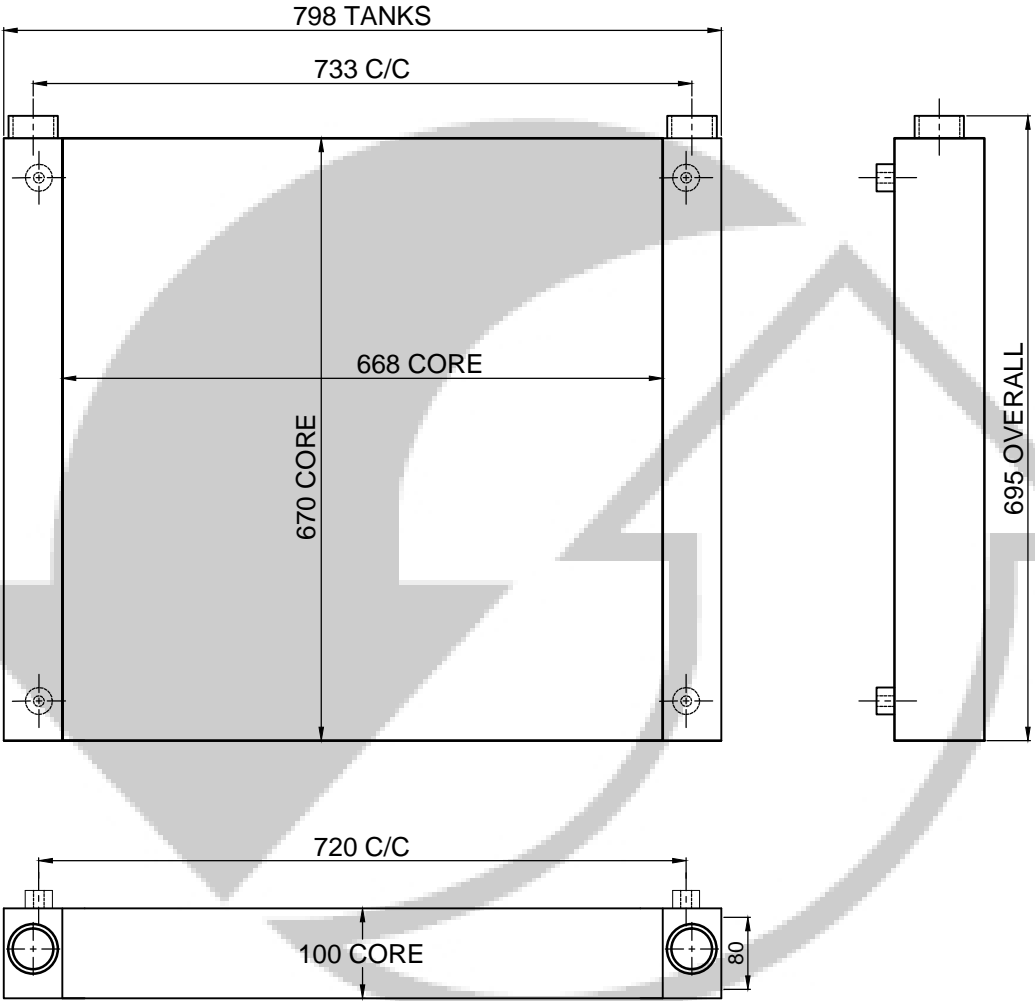

MODEL:HYDROVANE

PART NUMBER:OIL602 HYD1COM

# OILCOOLER-HYDROVANE

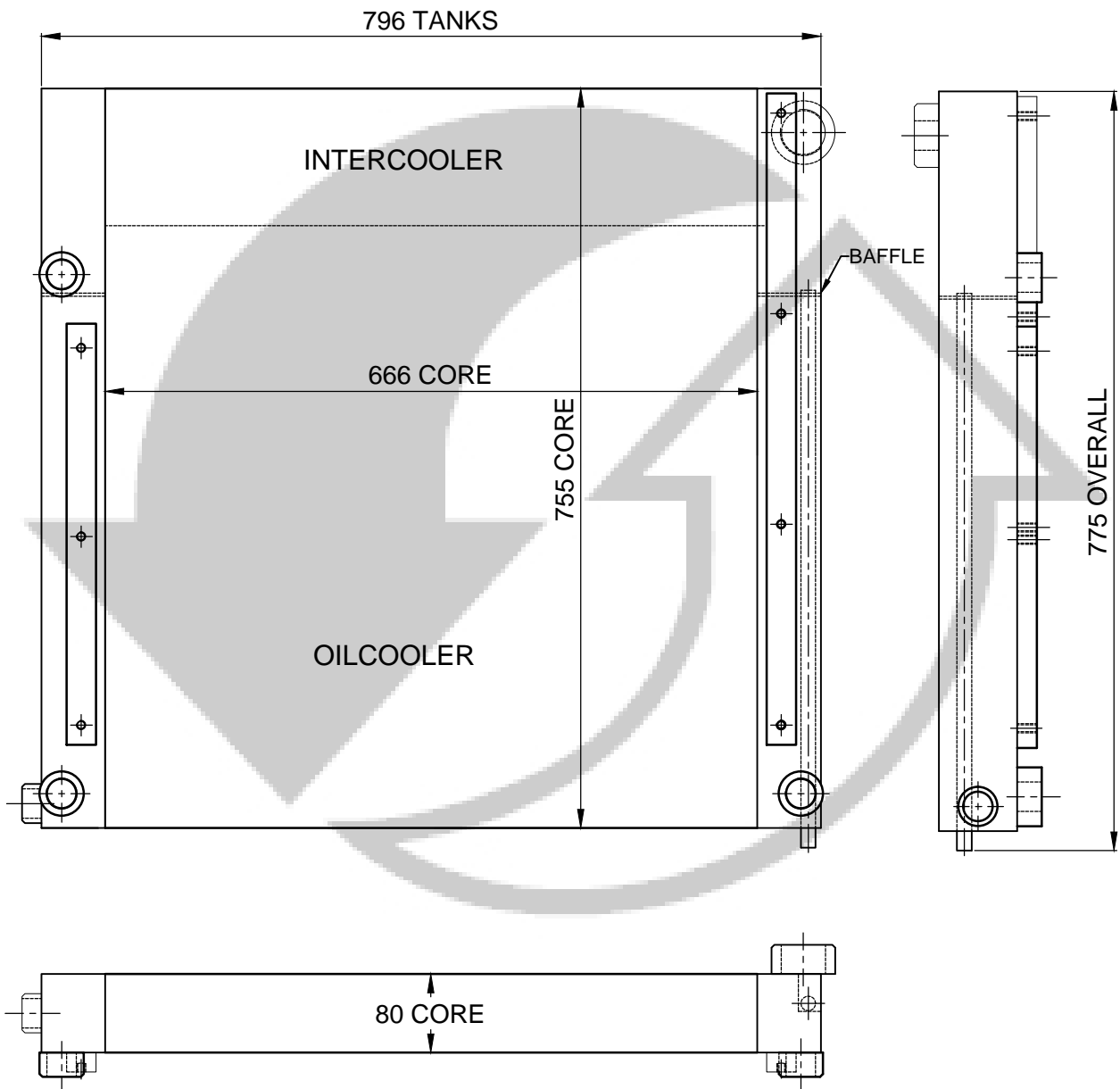

MODEL:HYDROVANE

PART NUMBER:OIL680HYD1COM

# OILCOOLER-HYUNDAI

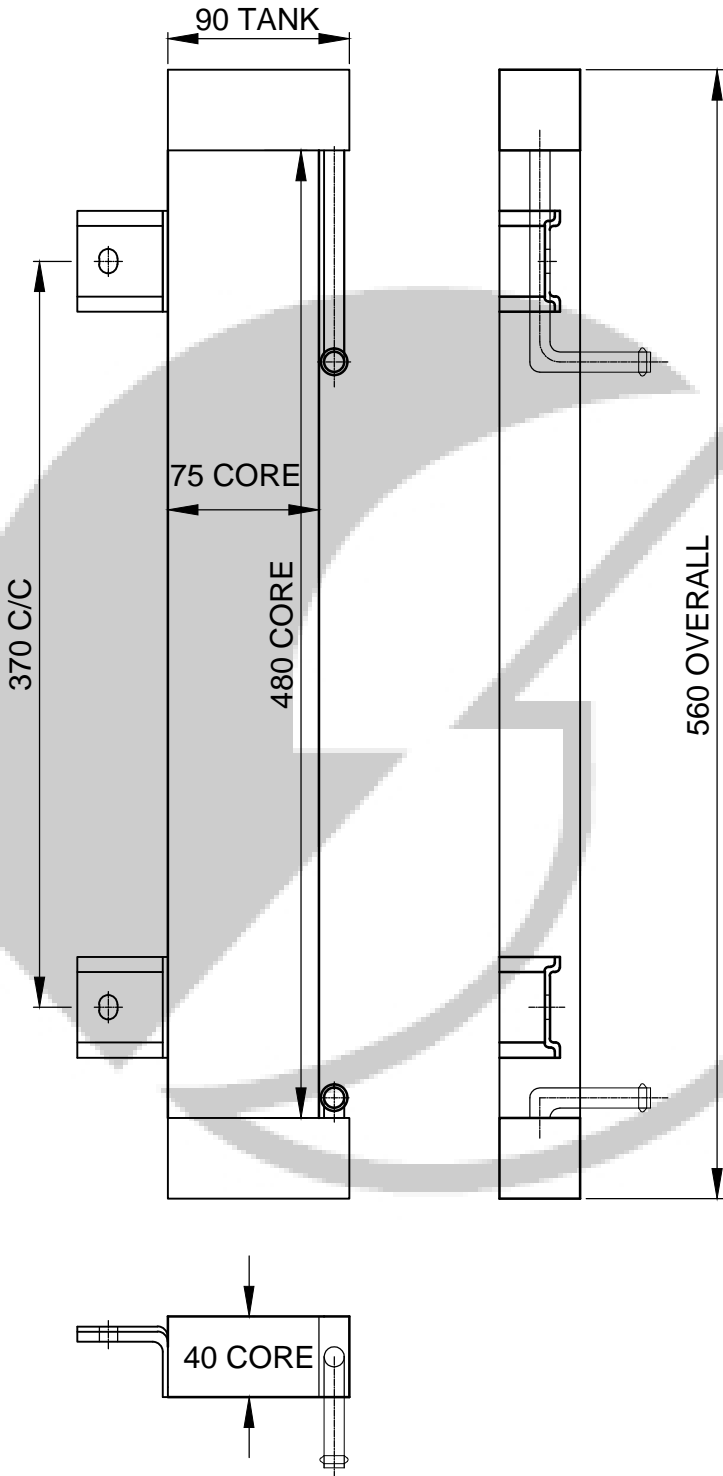

MODEL:HYUNDAI

PART NUMBER:OIL484HYU1COM

# OILCOOLER-INGERSOL RAND

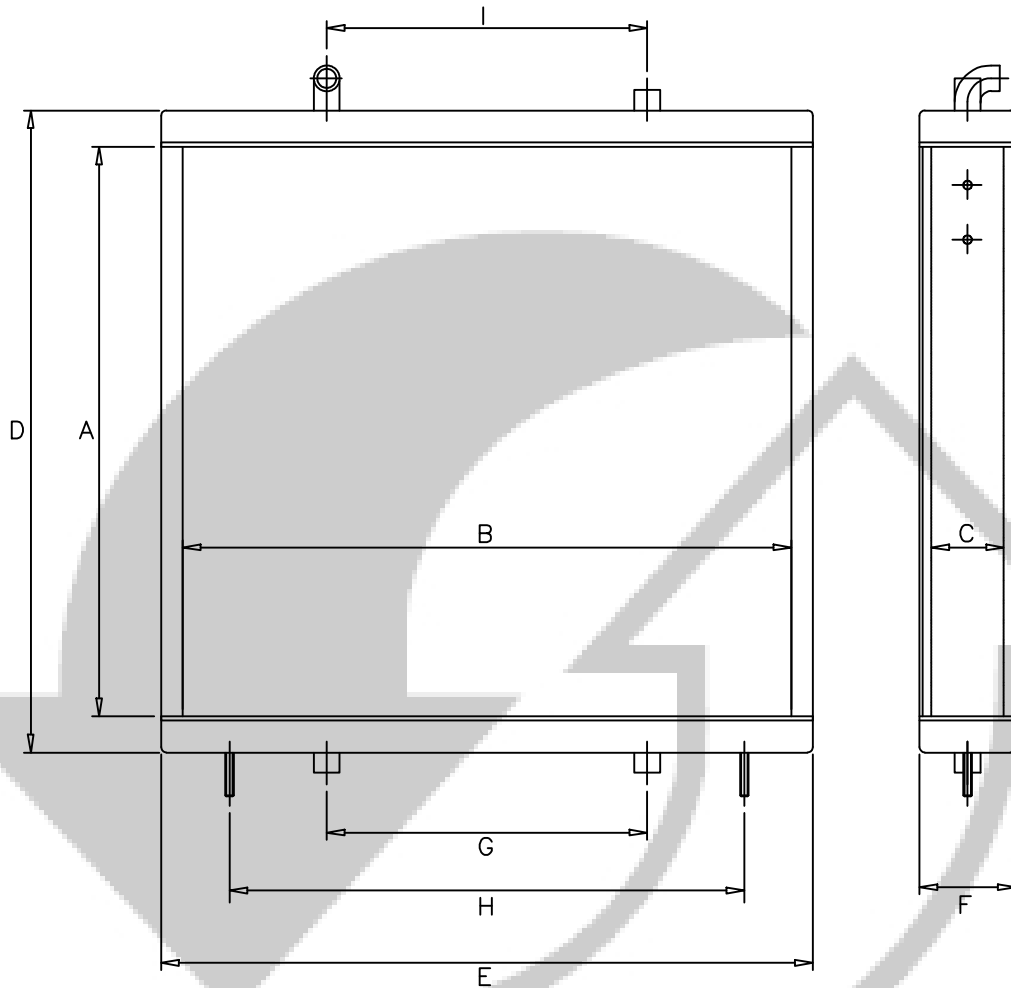

MODEL	CORE			OVERALL			OTHER			PART
	A	B	C	D	E	F	G	H	I	
533ING1	501	587	60	601	610	60	300	482	374	533ING1
584ING1	556	682	60	656	727	60	276	628	508	584ING1
686ING1	658	758	60	758	799	60	251	705	508	686ING1
838ING1	870	910	60	970	971	60	317	673	-	838ING1



MODEL:INGERSOL RAND DR 125,210,250,365  
 PART NUMBER:OIL533ING1COM,OIL5841COM,  
 OIL686ING1COM,OIL8381COM

# OILCOOLER-INGERSOL RAND

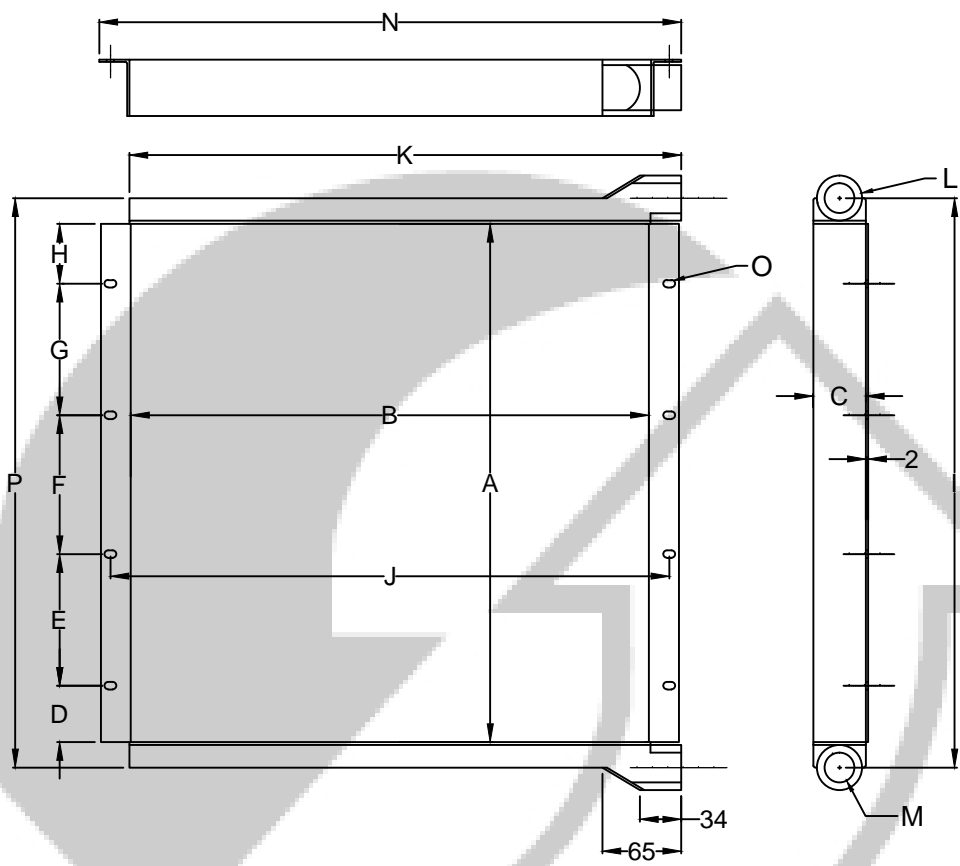

A	B	C	D	E	F	G	H	I	J	K	L	M	N	O	P
895	910	60	76.5	254	254	254	76.5	995	865	860	Ø57	1½"NPT	890	12x8 slot	995
735	728	60	38	228	228	228	38	845	768	765	Ø60	1½"NPT	798	12x8 slot	835



MODEL:INGERSOL RAND

PART NUMBER:915 ING1,760ING1

# OILCOOLER-JOHN DEERE

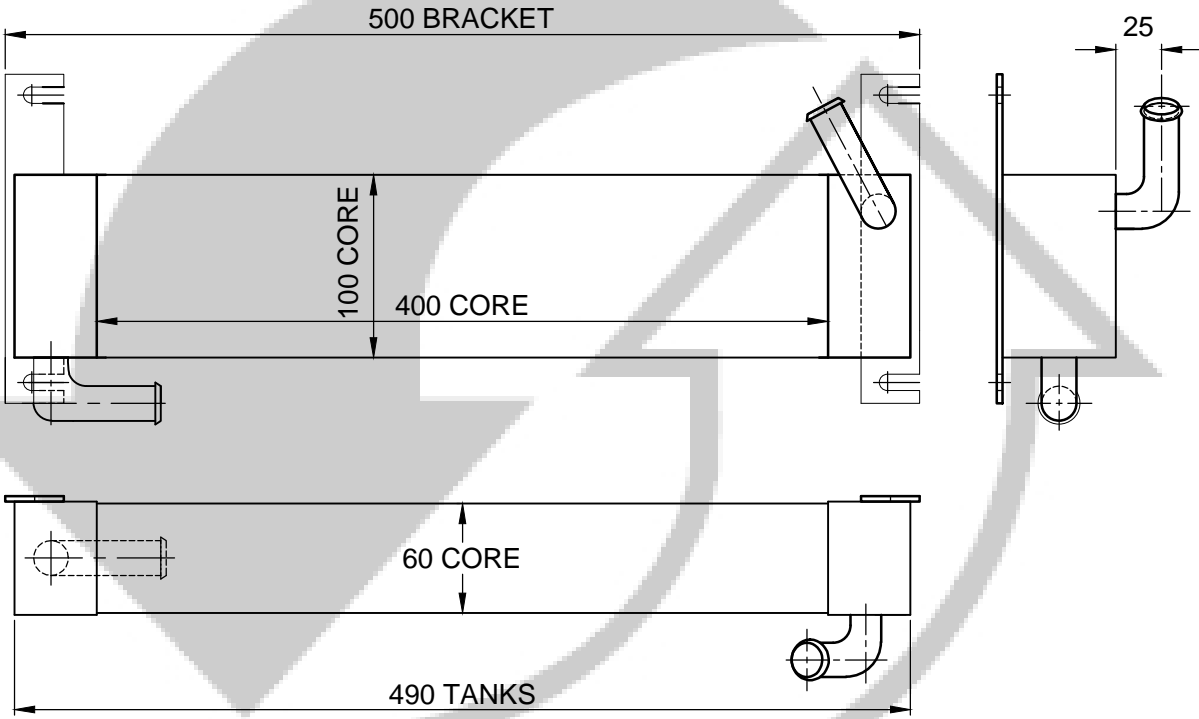

MODEL:JOHN DEERE

PART NUMBER:OIL400JOH1COM



# OILCOOLER-JOHN DEERE

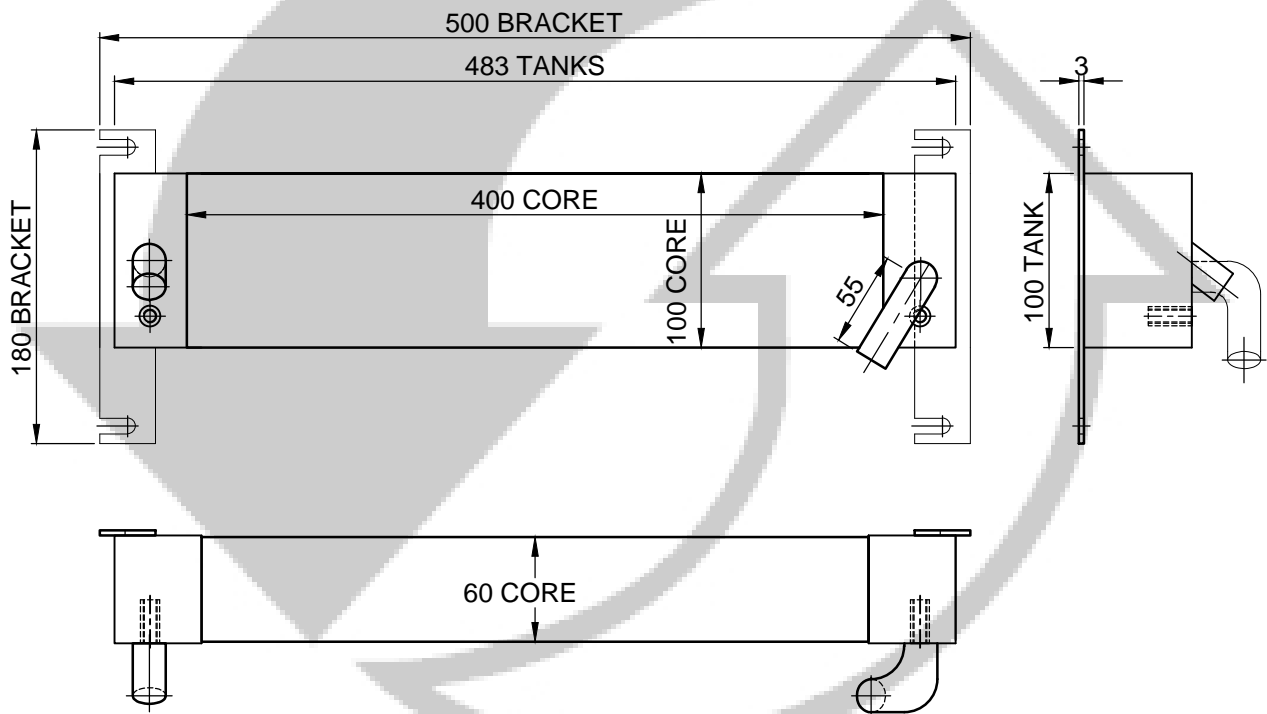

MODEL:JOHN DEERE

PART NUMBER:OIL400JOH2COM

# OILCOOLER-JOHN DEERE

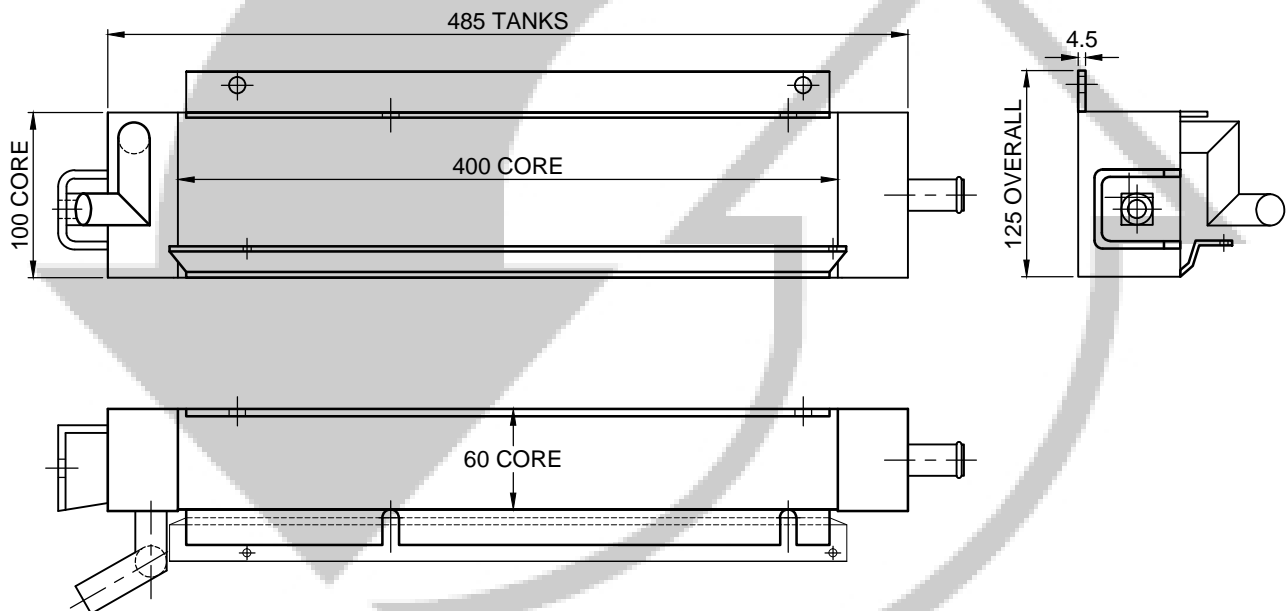

MODEL:JOHN DEERE

PART NUMBER:OIL400JOH3COM

# OILCOOLER-JOHN DEERE

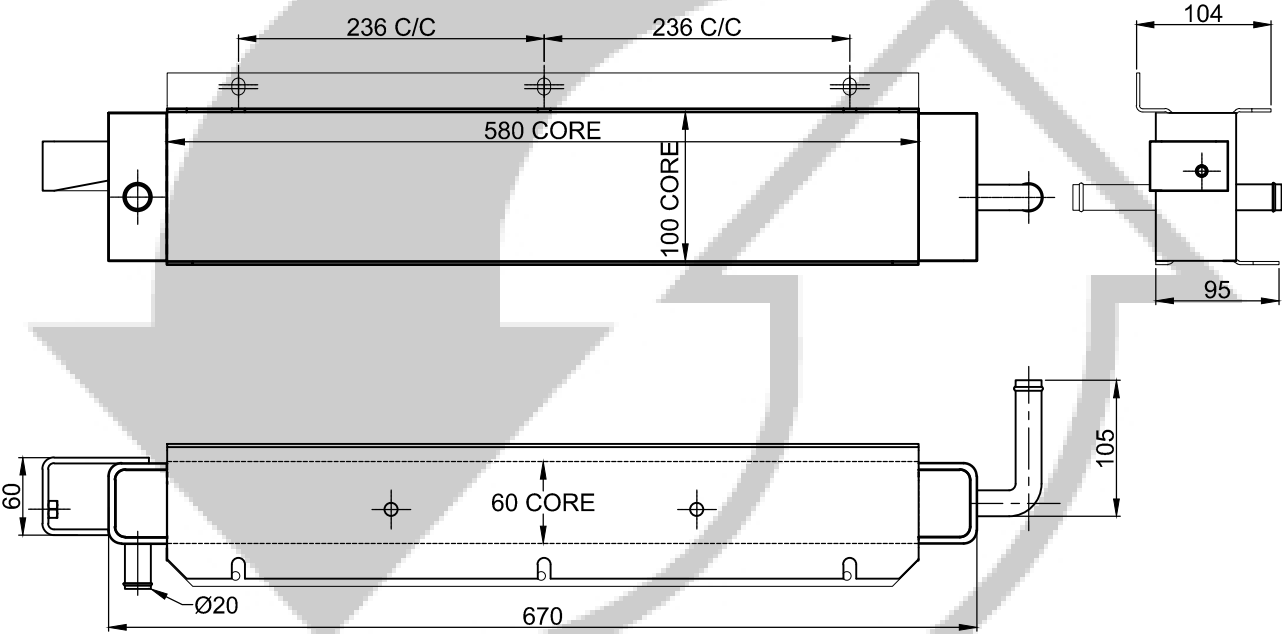

MODEL:JOHN DEERE

PART NUMBER:OIL580JOH1COM

# OILCOOLER-LINDE

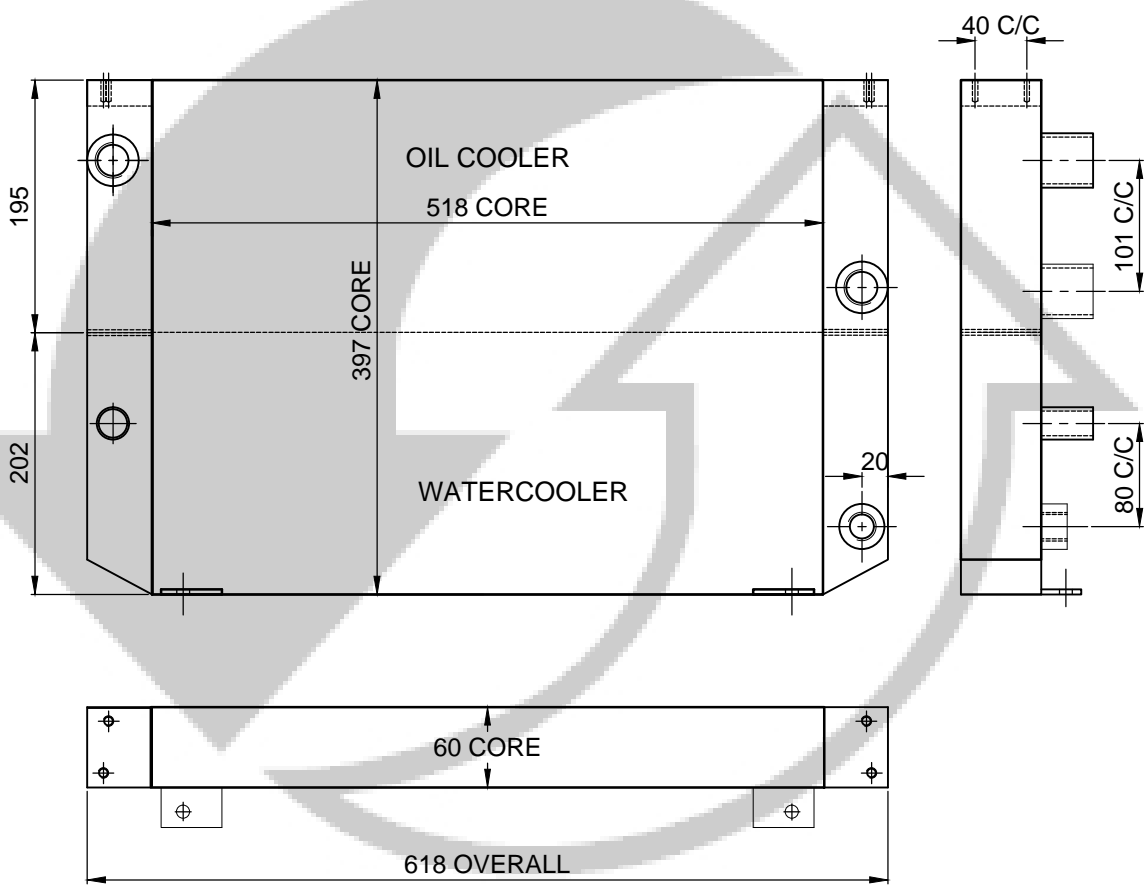

MODEL:LINDE

PART NUMBER:OIL502LIN1COM

# OILCOOLER-MAGIRUS

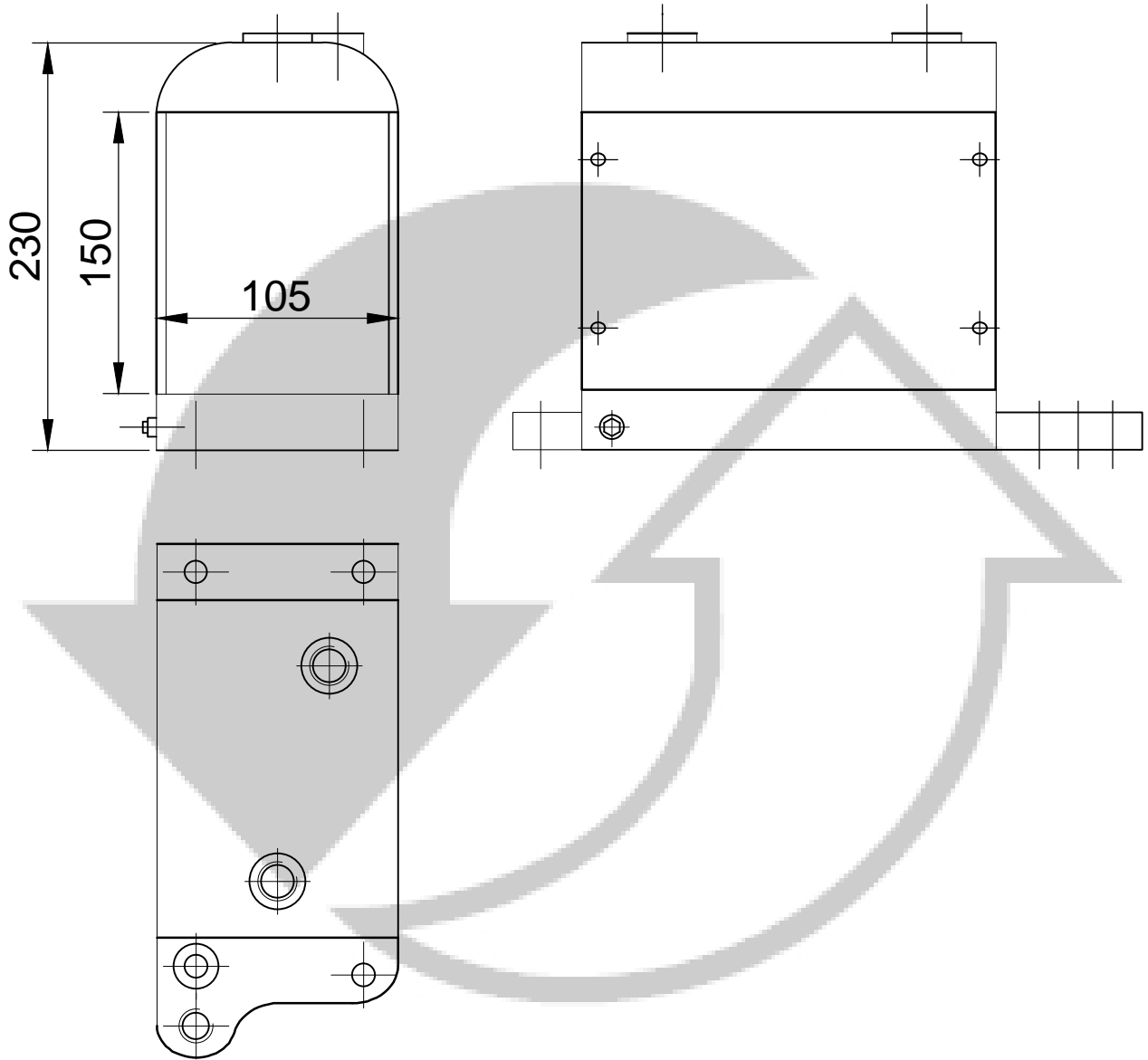

RECORE ONLY



MODEL:MAGIRUS DEUTZ

PART NUMBER:OIL150MAG1COM

# OILCOOLER-MAGIRUS

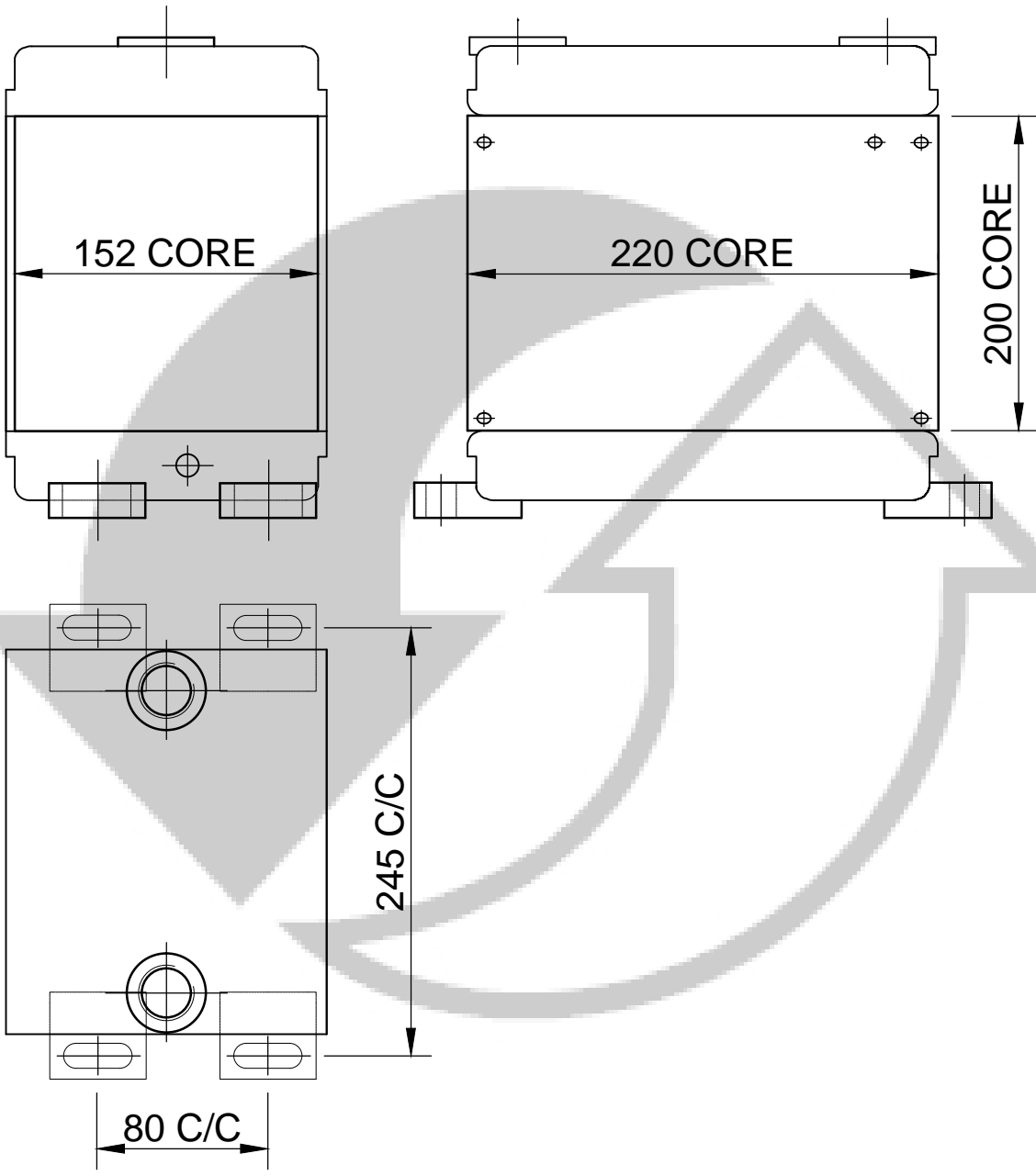

RECORE ONLY



MODEL:MAGIRUS DEUTZ

PART NUMBER:OIL180MAG1COM

# OILCOOLER-MAGIRUS

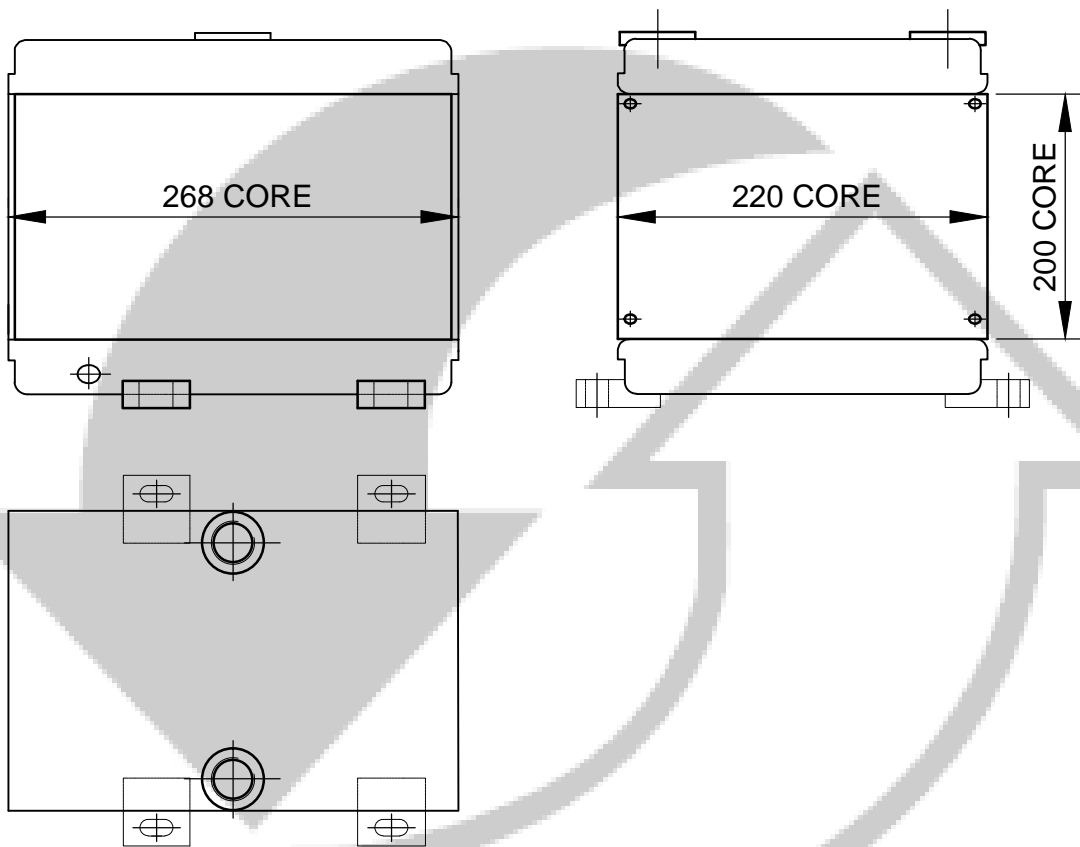

RECORE ONLY



MODEL:MAGIRUS DEUTZ

PART NUMBER:OIL180MAG2COM

# OILCOOLER-MAGIRUS

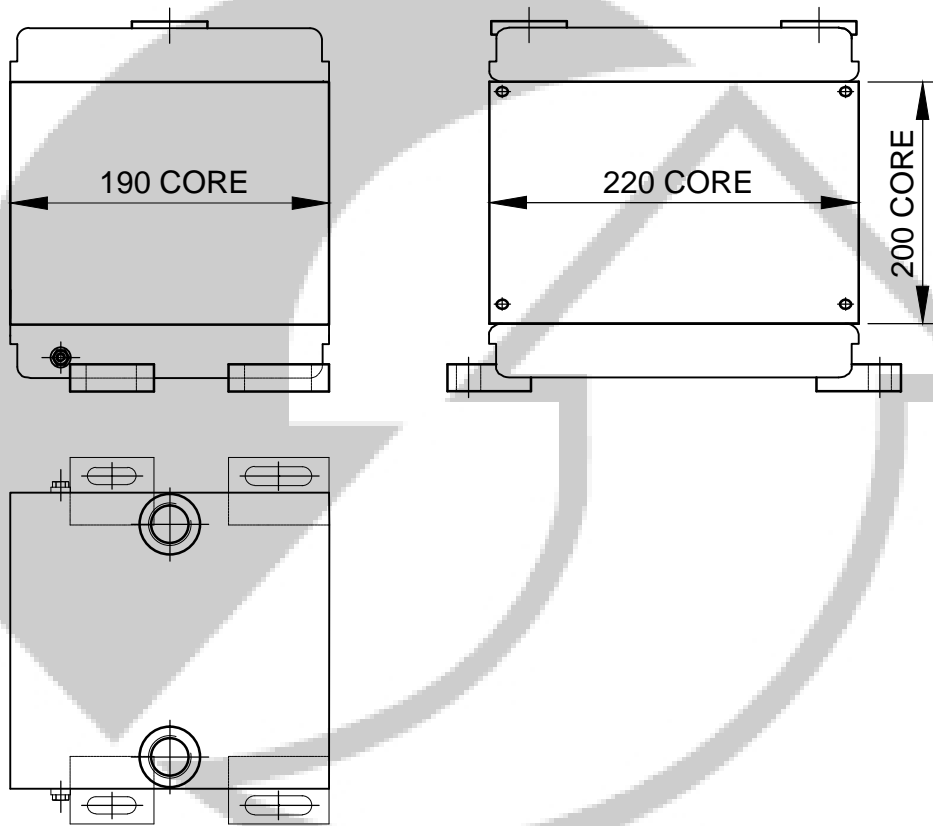

RECORE ONLY



MODEL:MAGIRUS DEUTZ

PART NUMBER:OIL180MAG3COM



# OILCOOLER-MAGIRUS

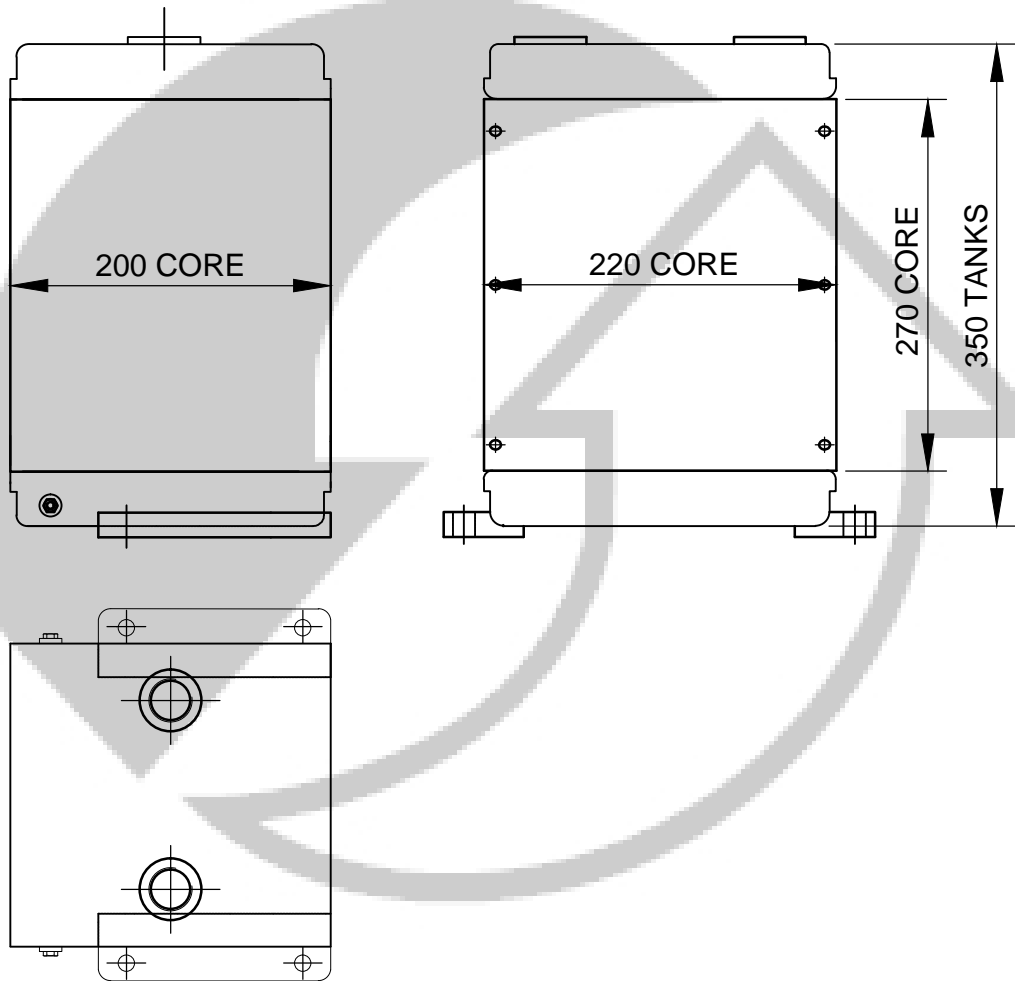

RECORE ONLY



MODEL:MAGIRUS DEUTZ

PART NUMBER:OIL270MAG1COM

# OILCOOLER-MAGIRUS

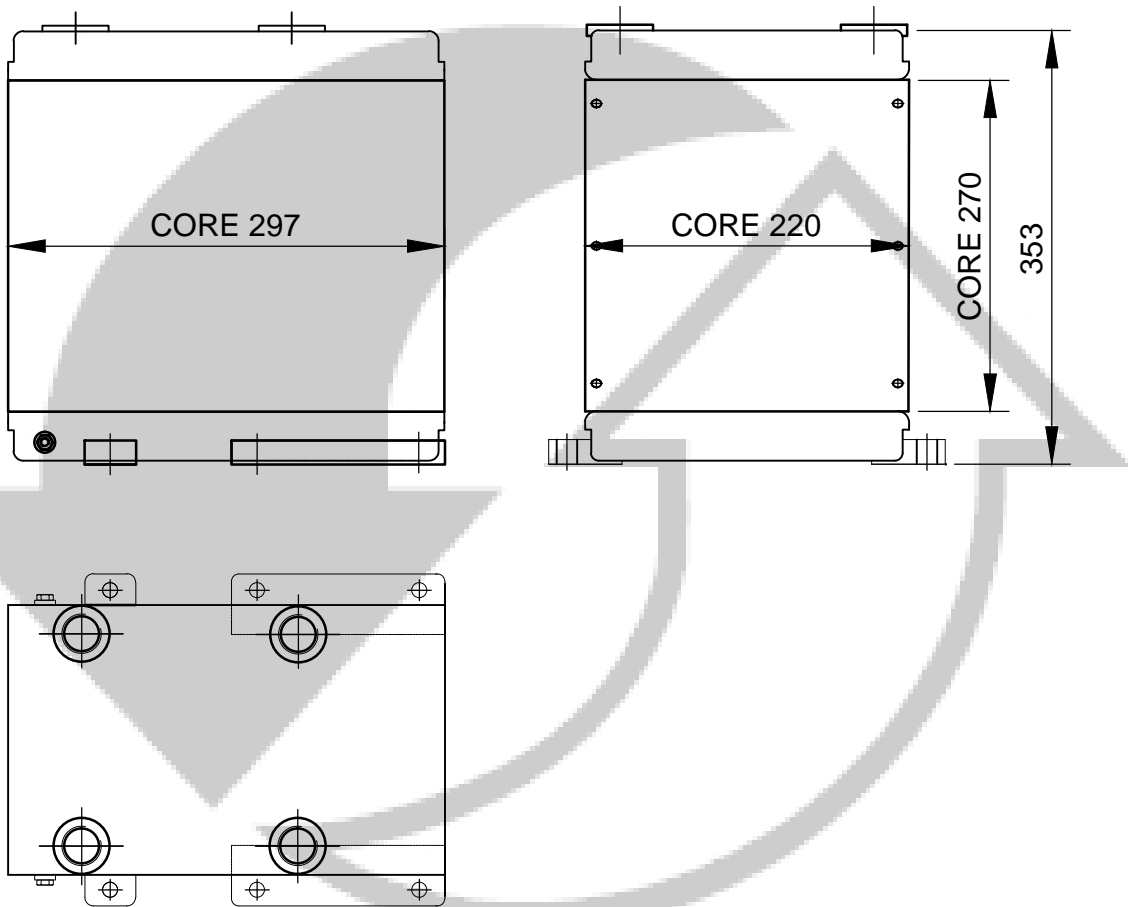

RECORE ONLY



MODEL:MAGIRUS DEUTZ

PART NUMBER:OIL270MAG2COM

# OILCOOLER-MAGIRUS

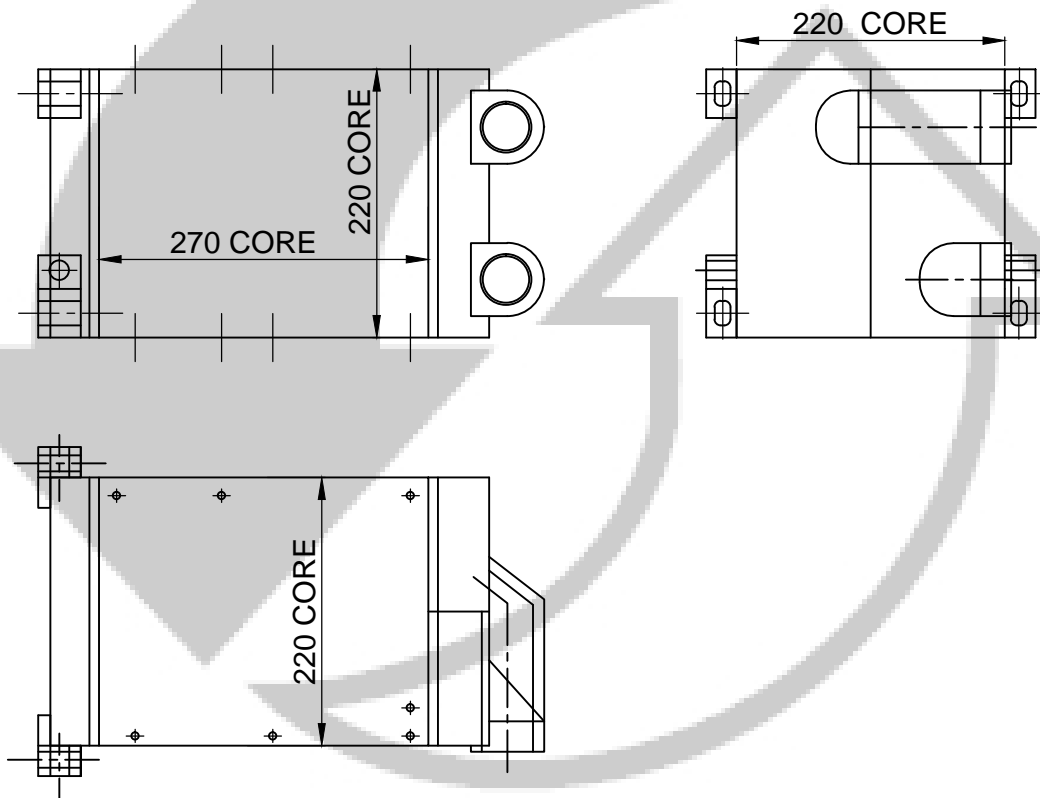

RECORE ONLY



MODEL:MAGIRUS DEUTZ

PART NUMBER:OIL270MAG3COM

# OILCOOLER-MAN

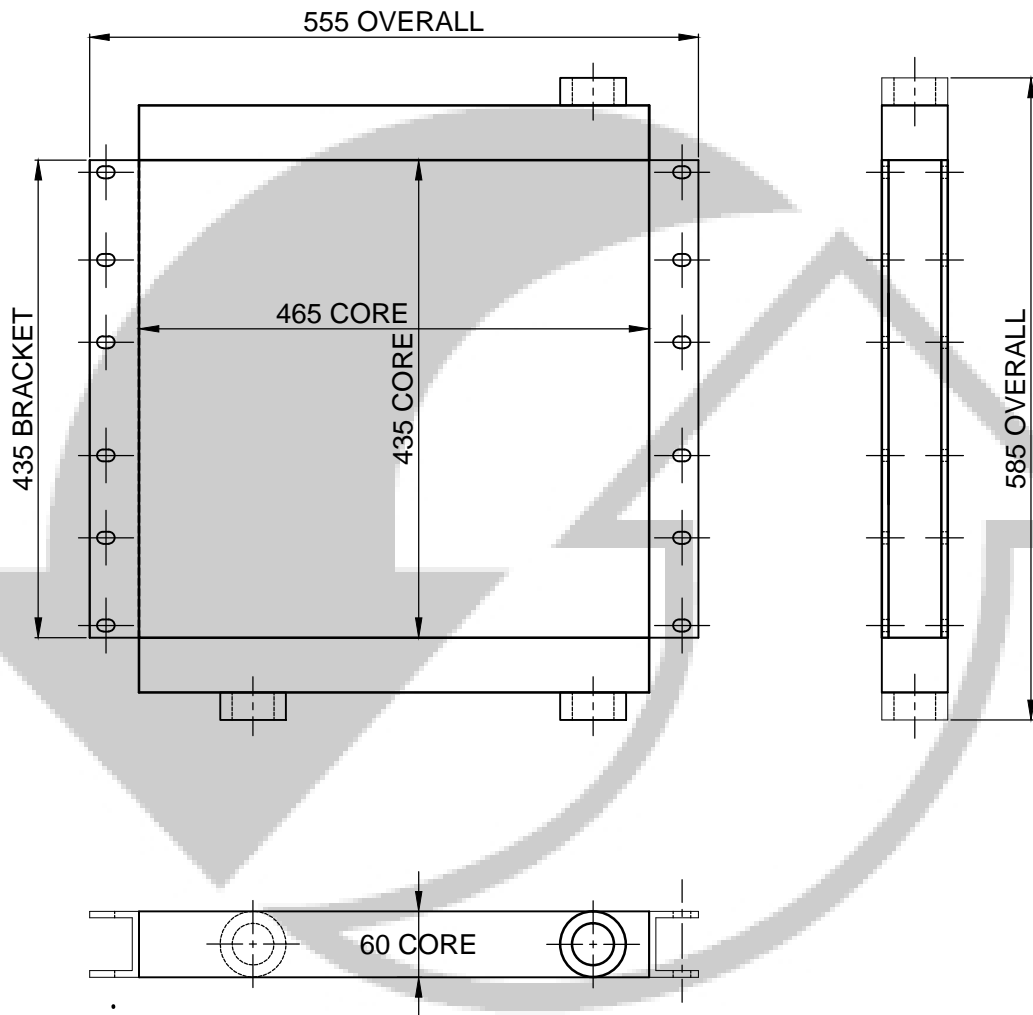

MODEL:MAN

PART NUMBER:OIL419MAN1COM

# OILCOOLER-MAN

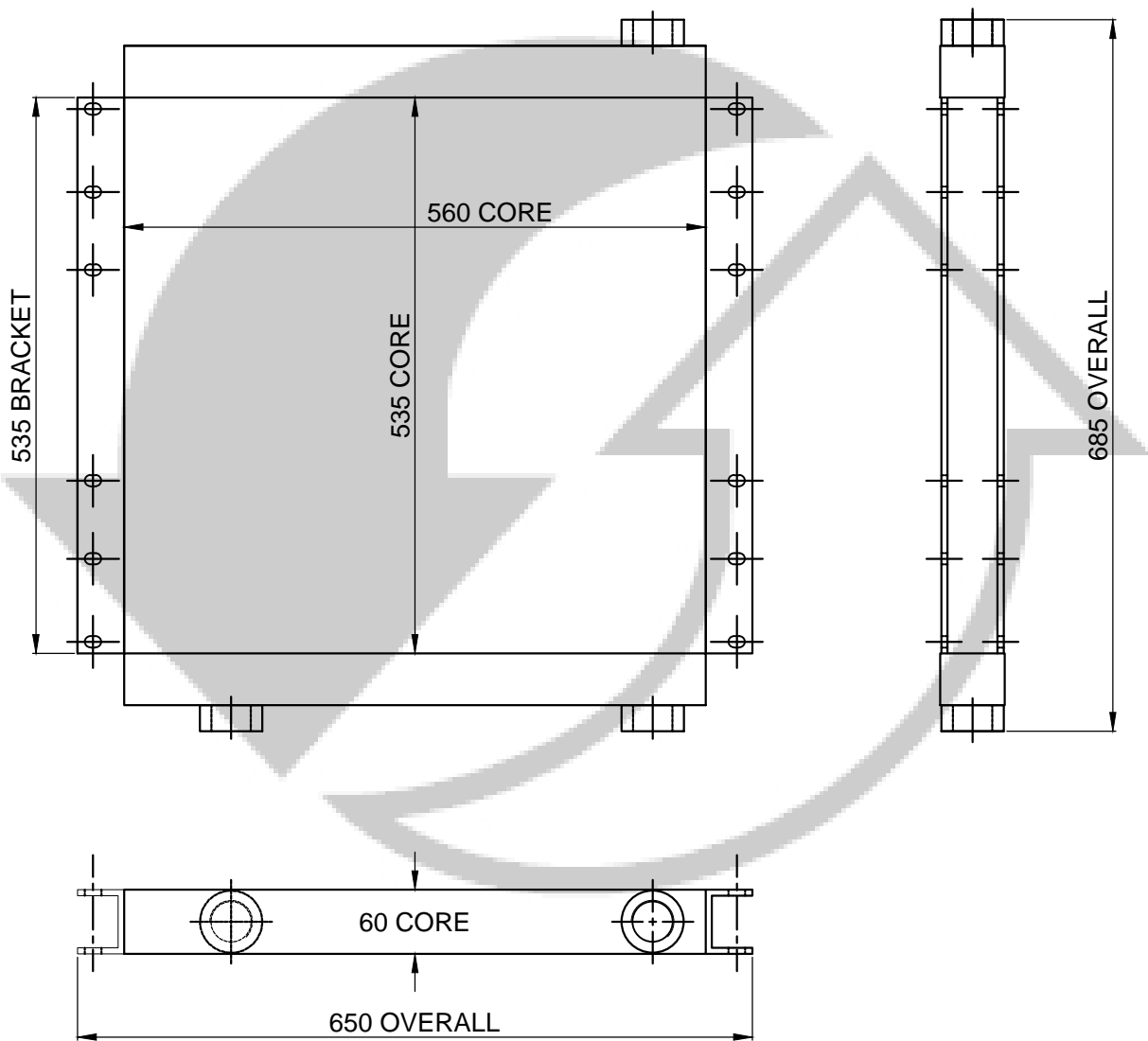

MODEL:MAN

PART NUMBER:OIL519MAN1COM

# OILCOOLER-MERCEDES BENZ

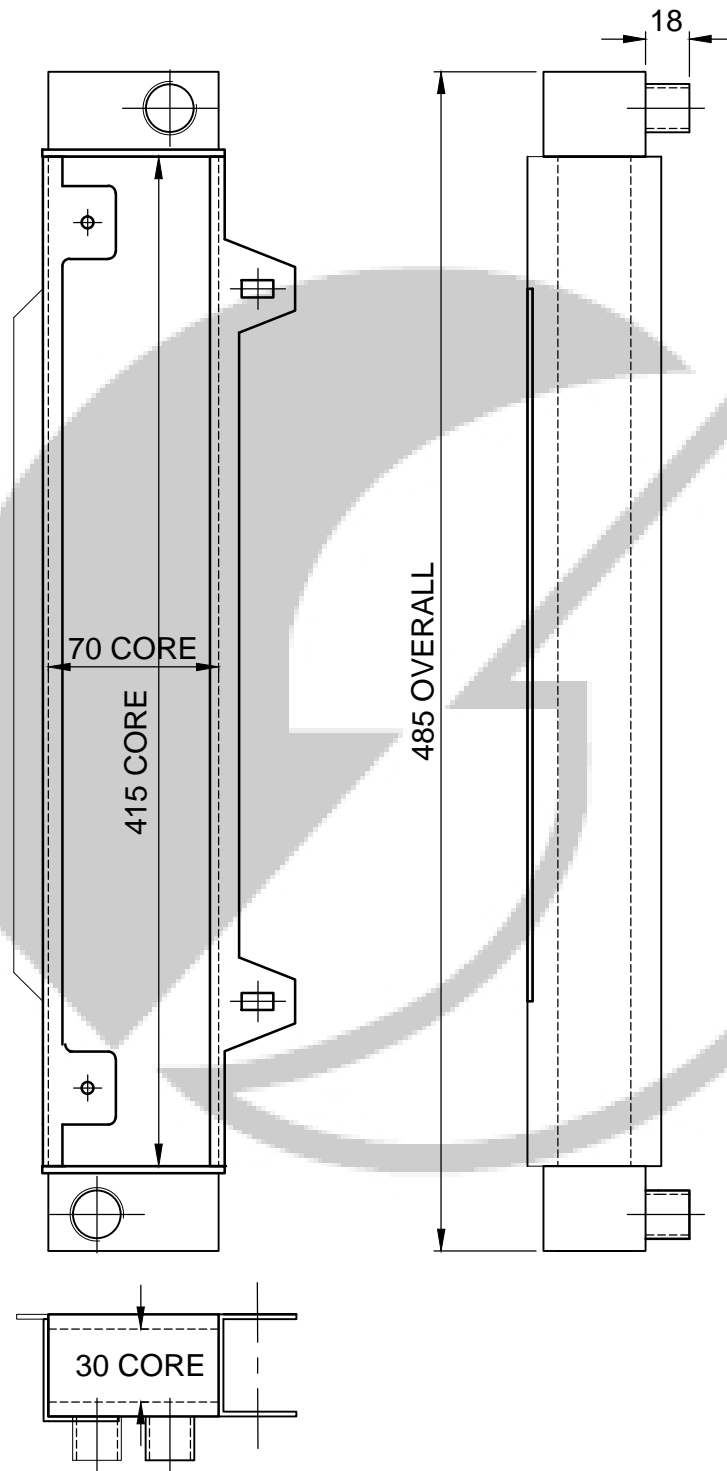

MODEL:MERCEDES BENZ

PART NUMBER:OIL415MER\_1COM

# OILCOOLER-MERCEDES BENZ

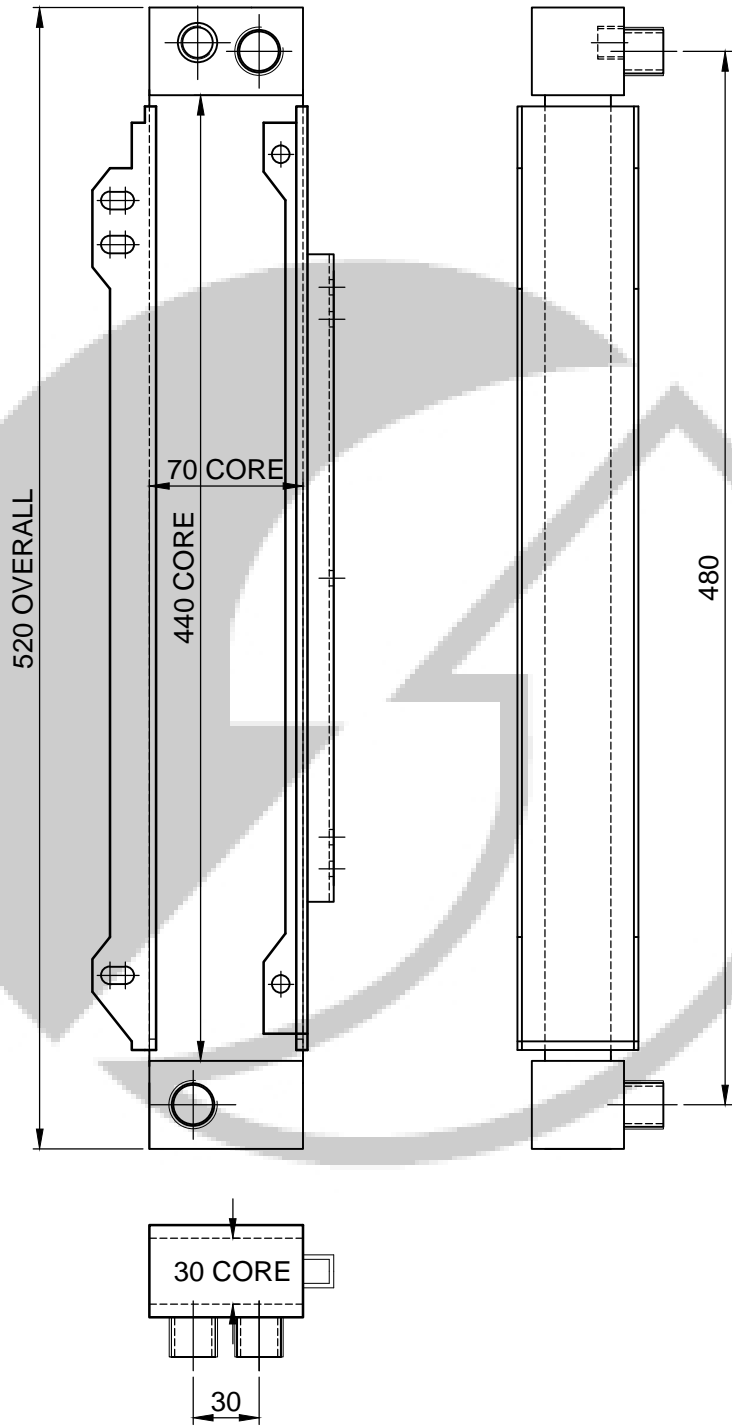

MODEL:MERCEDES BENZ

PART NUMBER:OIL440MER1COM

# OILCOOLER-MERCEDES BENZ

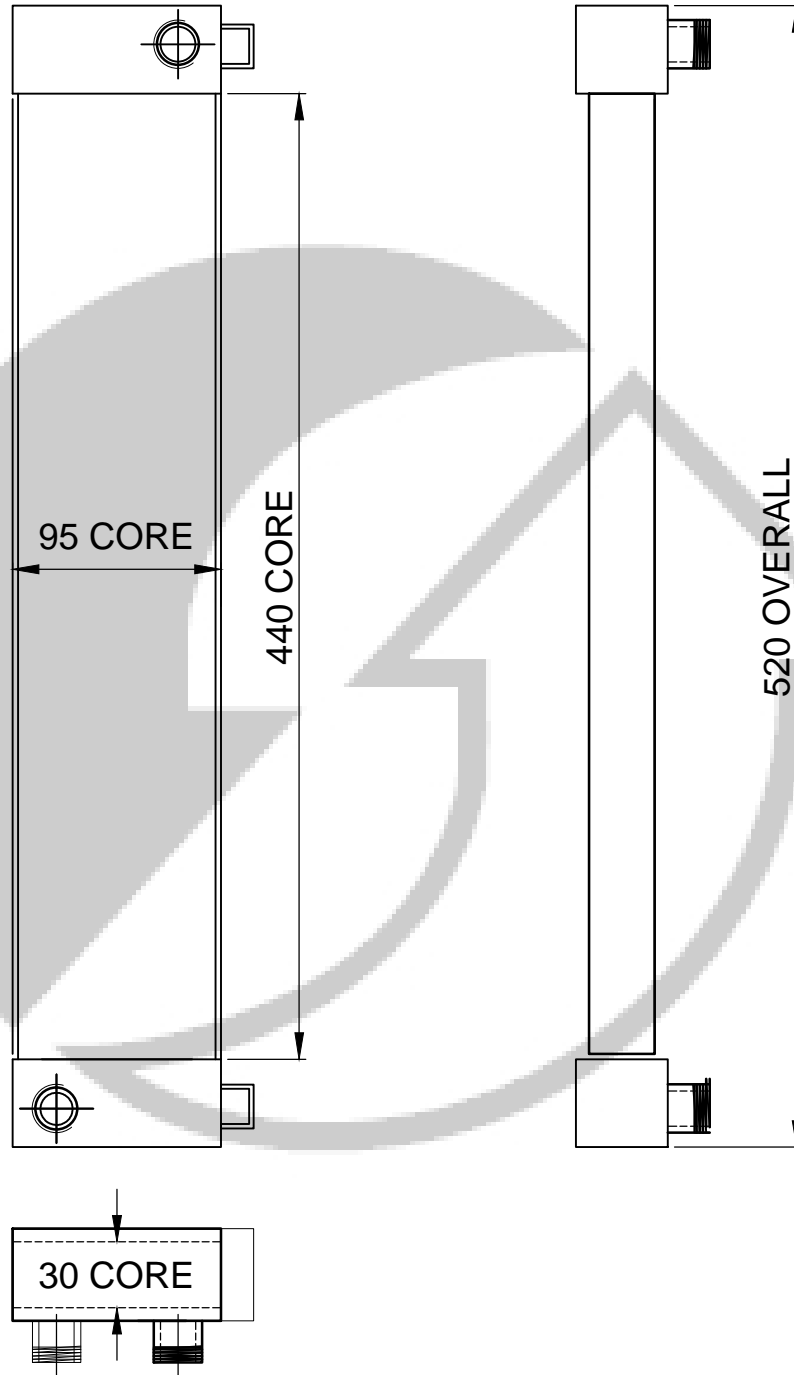

MODEL:MERCEDES BENZ

PART NUMBER:OIL440MER2COM



# OILCOOLER-MERCEDES BENZ

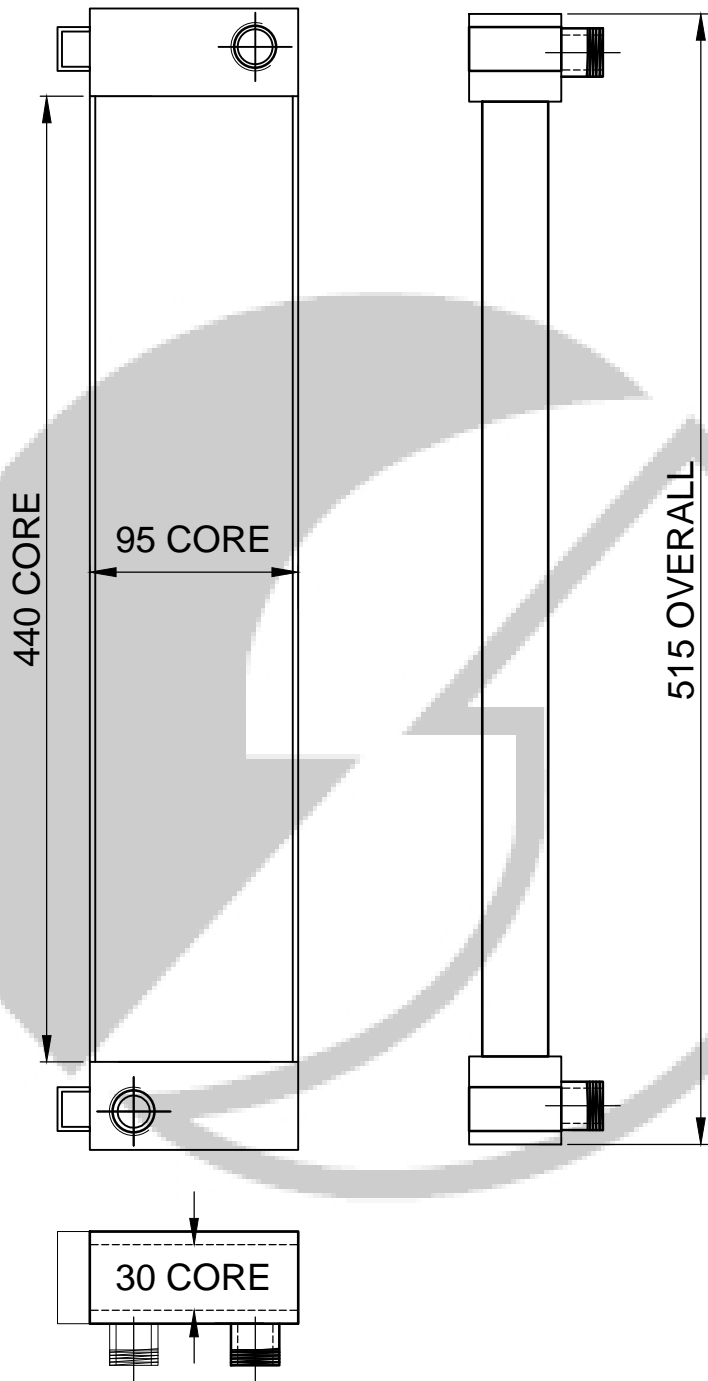

MODEL:MERCEDES BENZ

PART NUMBER:OIL440MER3COM

# OILCOOLER-MERCEDES BENZ

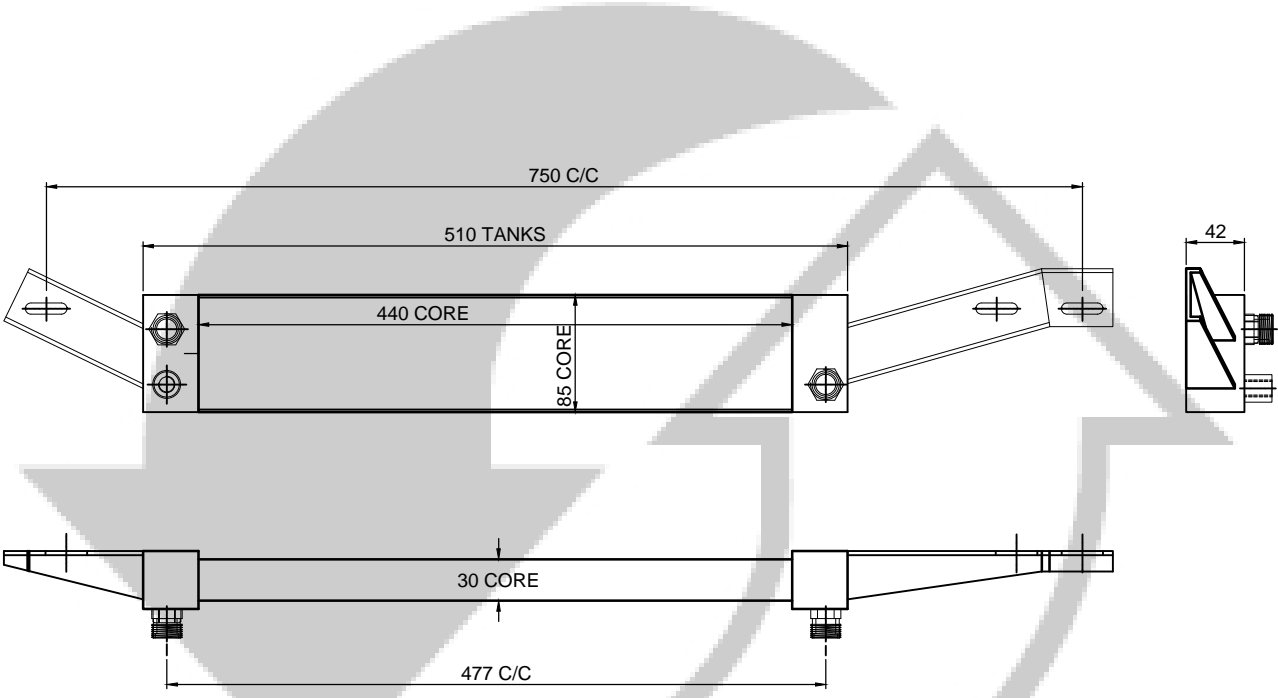

MODEL:MERCEDES BENZ

PART NUMBER:OIL440MER4COM

# OILCOOLER-MERCEDES BENZ

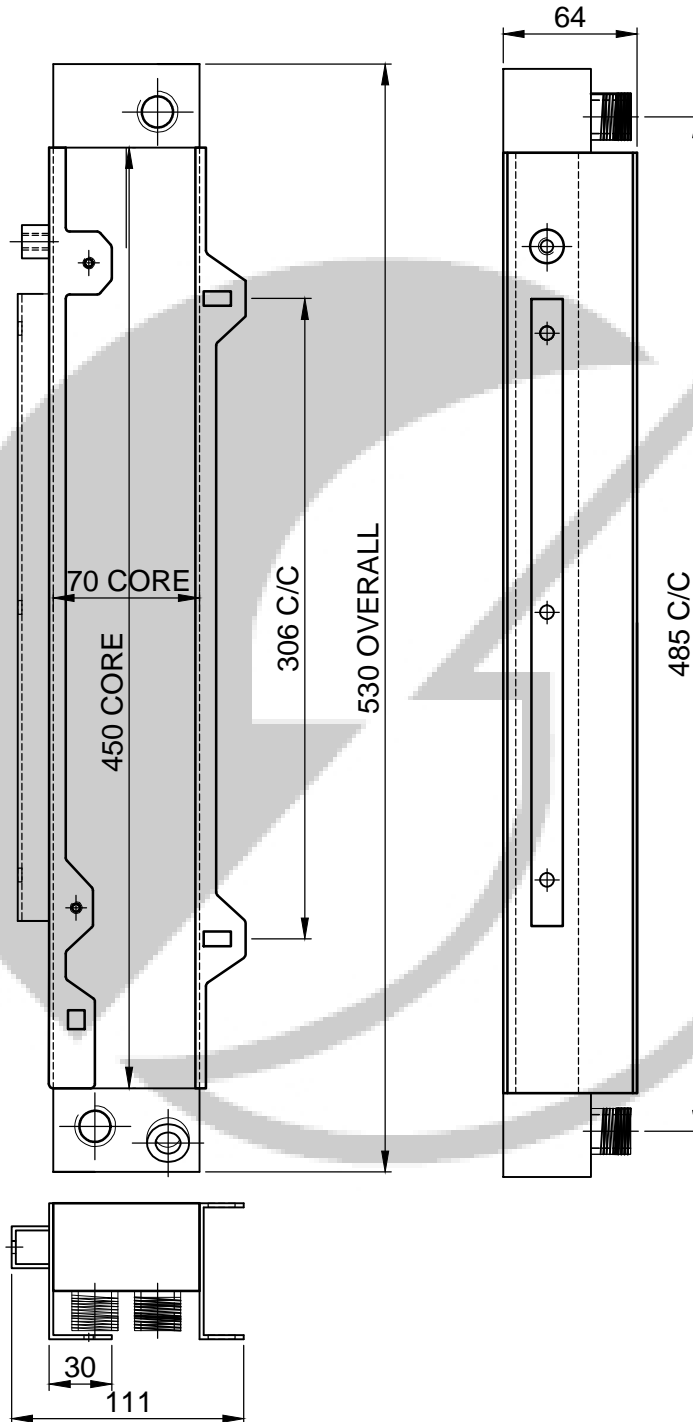

MODEL:MERCEDES BENZ

PART NUMBER:OIL450MER1COM

# OILCOOLER-MERCEDES BENZ

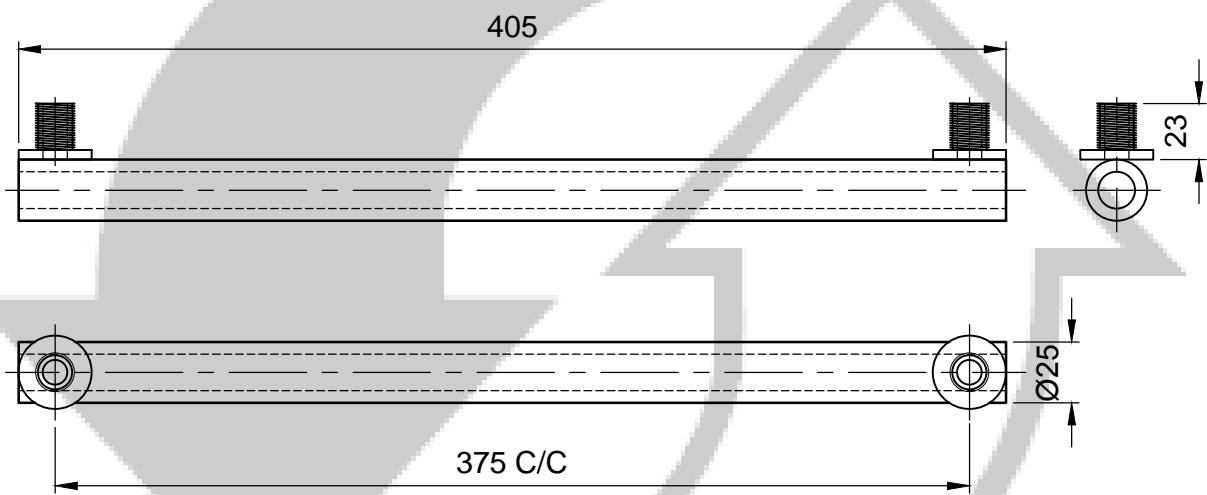

MODEL:MERCEDES BENZ

PART NUMBER:TMOC-DB405MER1COM

# OILCOOLER-NISSAN

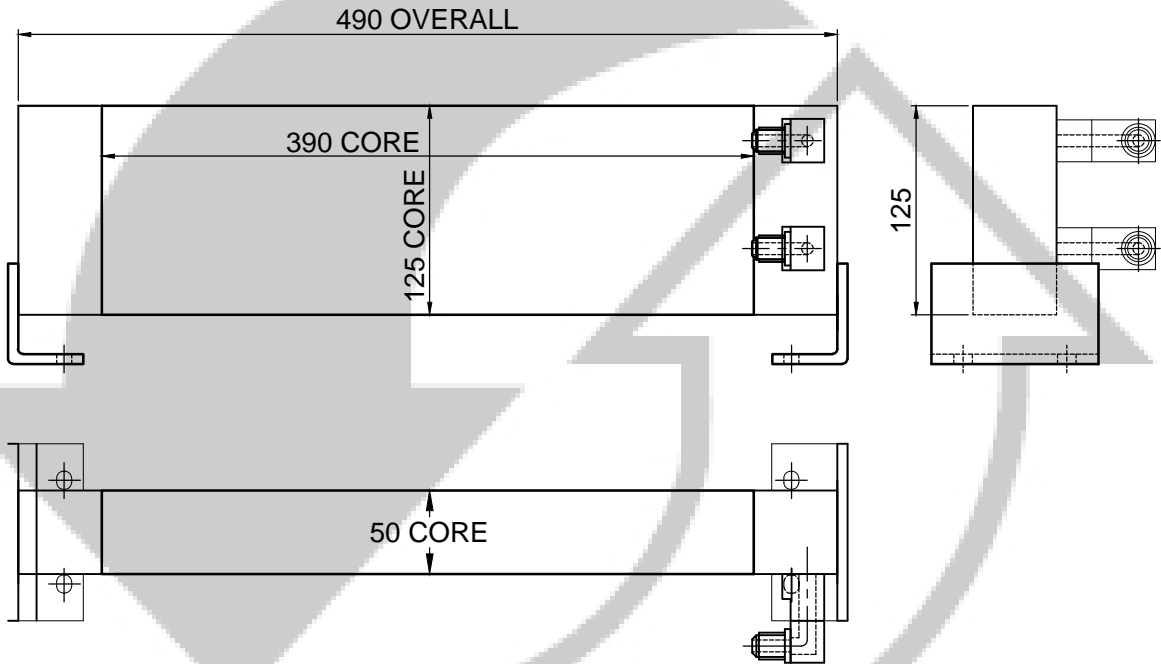

MODEL:NISSAN

PART NUMBER:OIL394NIS1COM

# OILCOOLER-TUBE AND SHELL

Cape Heat Exchange is proud to announce the newly developed **SB-cooler** range. This is a replacement range for the popular Bowman heat exchangers. Similar to the Bowman heat exchangers it will be a tube and shell heat exchanger with either a copper or copper-nickel tube stack depending on whether the unit is used with fresh water or sea water. Different to the Bowman series this unit will have a full stainless steel 316 shell with end-caps and so move away from the pre-casted aluminium shells. This will also allow us to be more flexible to customer specifications as we aren't restricted by pre-casted shells and can manufacture to customer specific requirements. The stainless steel shell will increase the durability of the units and because the Bowman heat exchangers is a UK based product the lead time will be substantially less to produce locally.

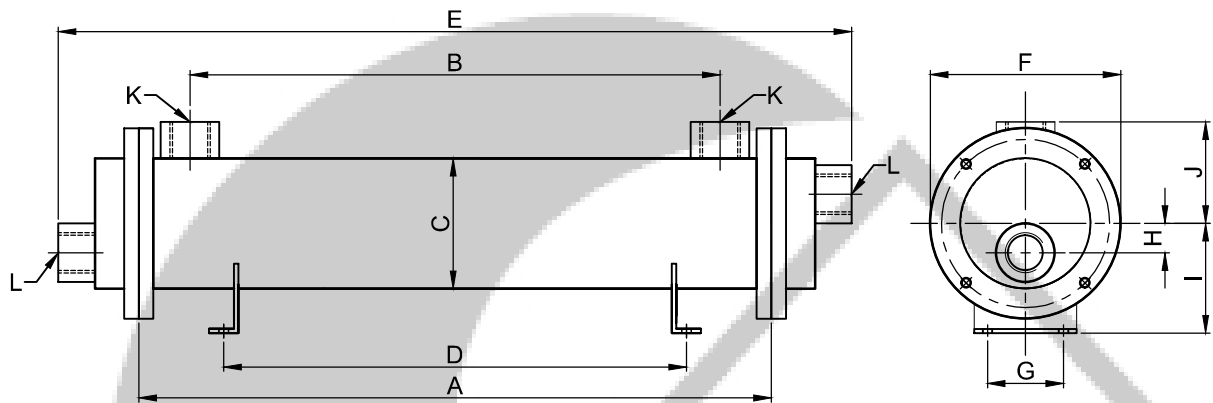

Model	# Tubes	A	B	C	D	E	F	G	H	I	J	K & L
83/210	65	210	140	89	104	320	130	52	20	71	69	3/4"
83/300	65	300	226	89	190	410	130	52	20	71	69	3/4"
83/400	65	400	324	89	288	510	130	52	20	71	69	3/4"
83/525	65	525	452	89	416	635	130	52	20	71	69	3/4"
108S/280	117	280	202	114	190	400	165	76	25	93	83	1"
108S/380	117	380	300	114	288	500	165	76	25	93	83	1"
108S/510	117	510	428	114	288	630	165	76	25	93	83	1"
108S/650	117	650	574	114	434	770	165	76	25	93	83	1"
108L/380	123	380	294	114	190	500	165	76	25	93	83	1 1/4"
108L/510	123	510	422	114	318	630	165	76	25	93	83	1 1/4"
108L/650	123	650	568	114	464	770	165	76	25	93	83	1 1/4"
108L/840	123	840	746	114	642	960	165	76	25	93	83	1 1/4"
135/370	197	370	272	141	108	510	215	120	38	117	108	1 1/2"
135/650	197	650	546	141	382	790	215	120	38	117	108	1 1/2"
135/830	197	830	724	141	560	970	215	120	38	117	108	1 1/2"
135/1030	197	1030	926	141	762	1170	215	120	38	117	108	1 1/2"



MODEL: TUBE AND SHELL/SB RANGE

PART NUMBER: SB83 TO SB135

# OILCOOLER-SUZUKI

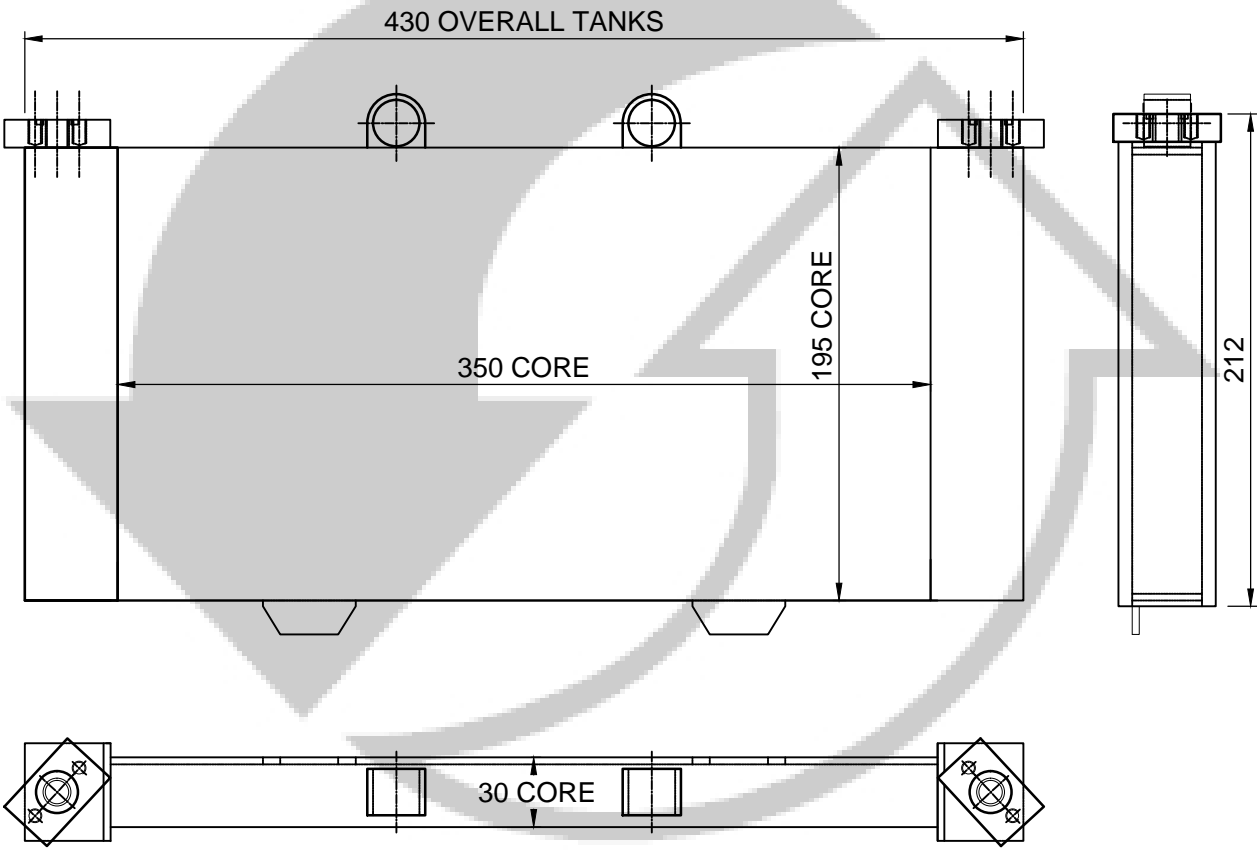

MODEL:SUZUKI

PART NUMBER:OIL356SUZ1COM

# OILCOOLER-SUZUKI

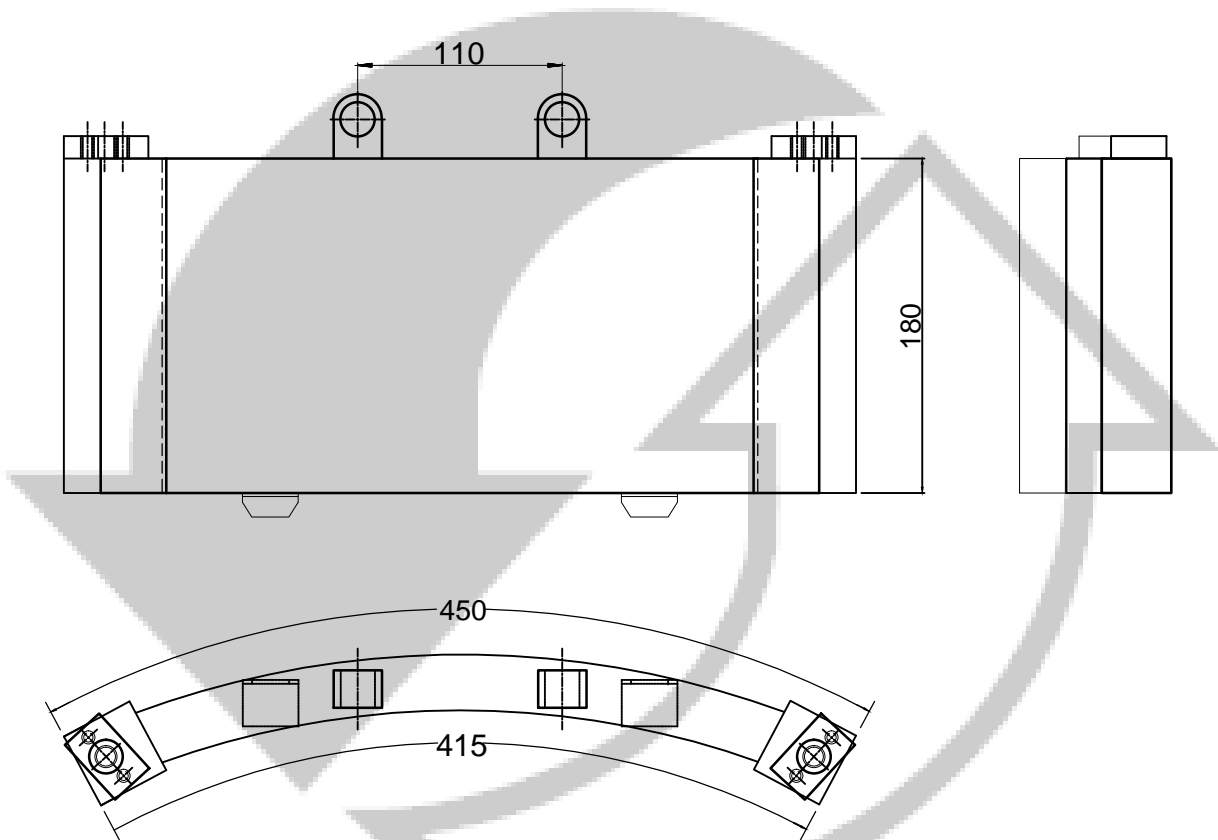

MODEL:SUZUKI

PART NUMBER:OIL368SUZ1COM



# OILCOOLER-SCANIA

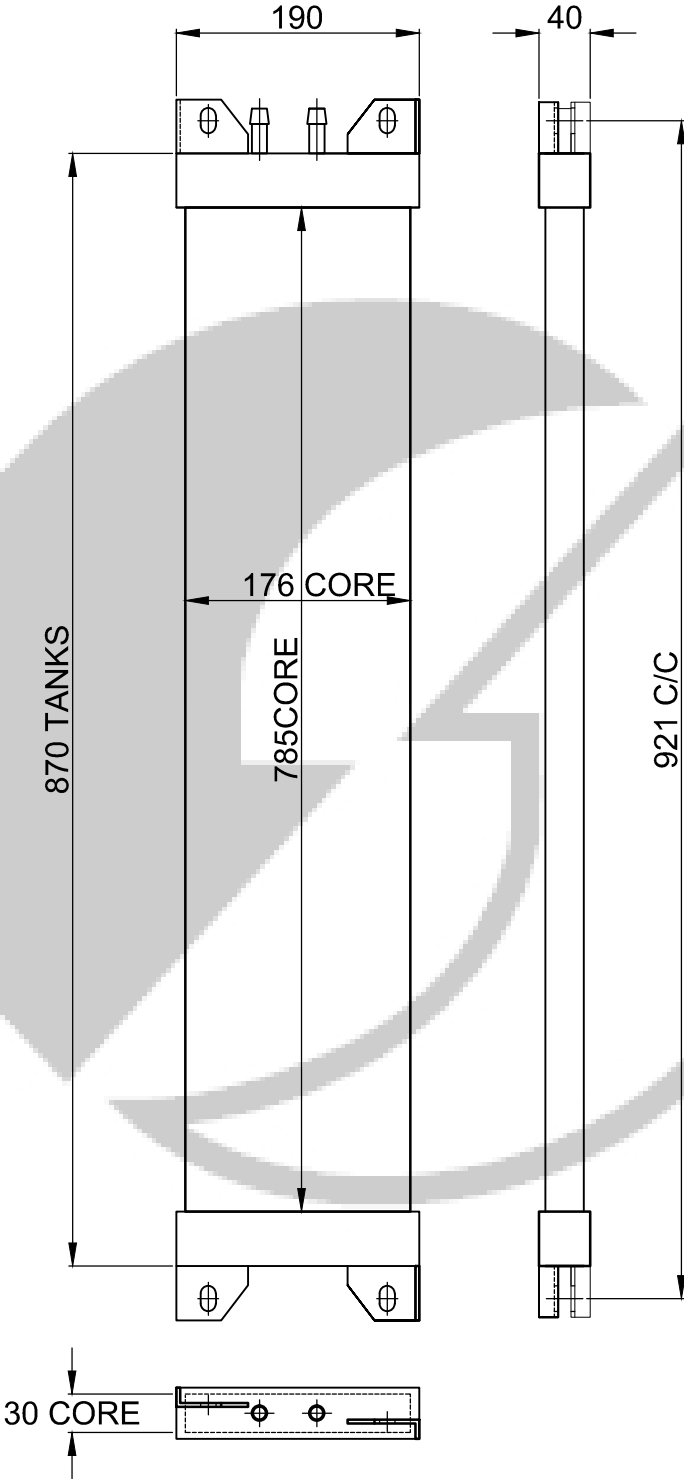

MODEL:SCANIA

PART NUMBER:OIL785SCA1COM

# OILCOOLER-TOYOTA

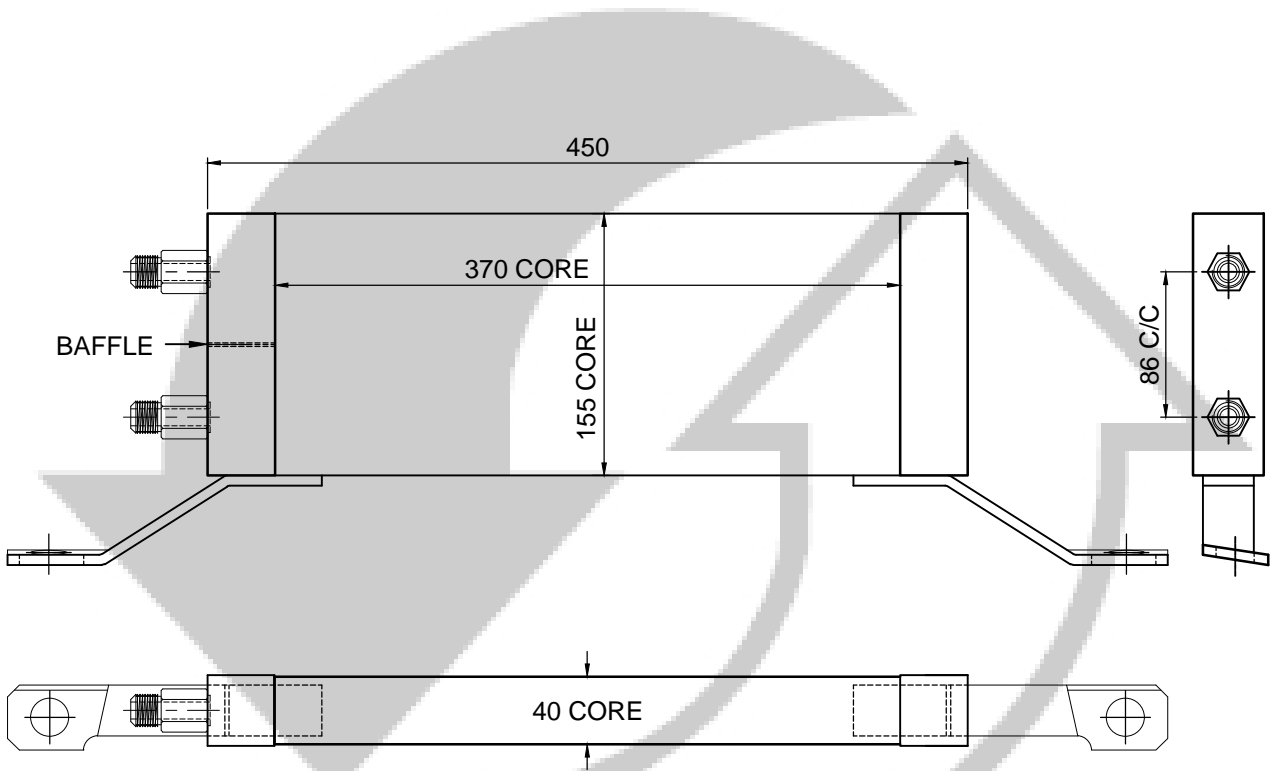

MODEL:TOYOTA

PART NUMBER:OIL400TOY1COM

# OILCOOLER-ZIP COOLER

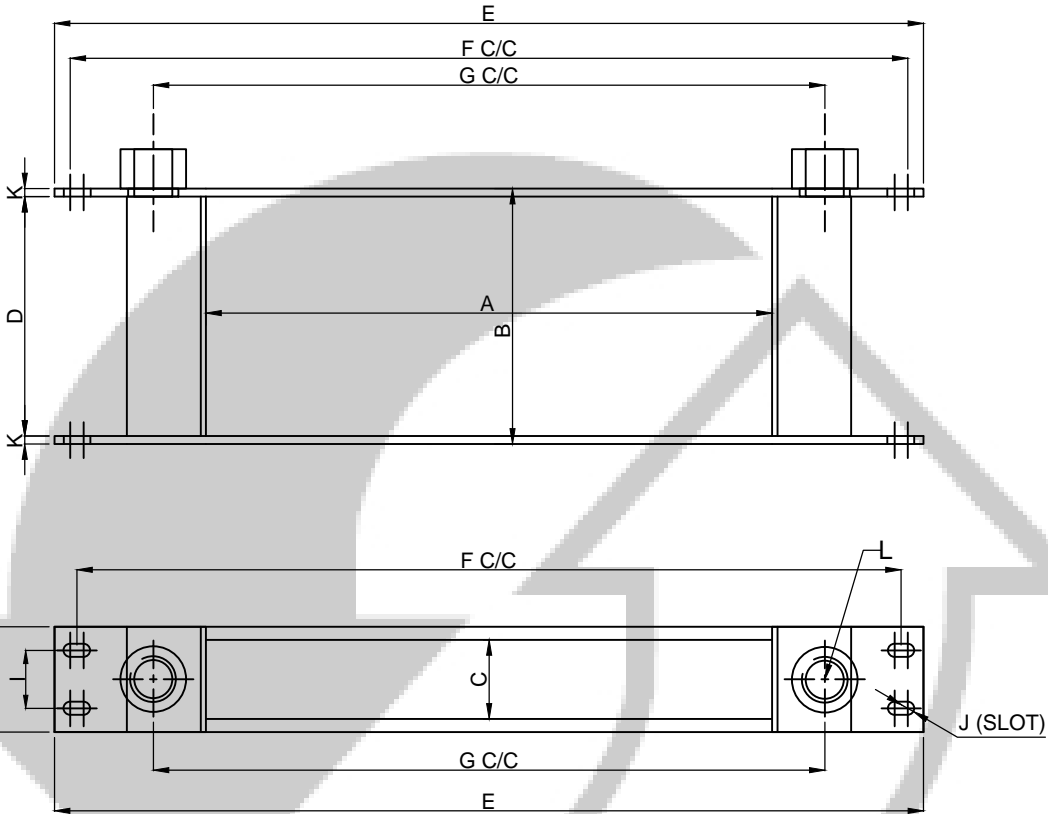

MODEL	A	B	C	D	E	F	G	H	I	J (SLOT)	K	L
ZIP3	215	60	30	54	330	312	248	42	22	Ø5 X 10	3	3/8NPT X 18TPI
ZIP5	215	80	30	74	330	312	248	42	22	Ø5 X 10	3	3/8NPT X 18TPI
ZIP7	215	96	30	90	330	312	248	42	22	Ø5 X 10	3	3/8NPT X 18TPI
ZIP9	215	125	30	119	330	312	248	42	22	Ø5 X 10	3	3/8NPT X 18TPI
ZIP11	215	150	30	144	330	312	248	42	22	Ø5 X 10	3	3/8NPT X 18TPI
ZIP13	215	167	30	161	330	312	248	42	22	Ø5 X 10	3	3/8NPT X 18TPI
ZIP15	215	200	30	194	330	312	248	42	22	Ø5 X 10	3	3/8NPT X 18TPI



MODEL:ZIP COOLER

PART NUMBER:

# TRANSMISSION OILCOOLER - FORD

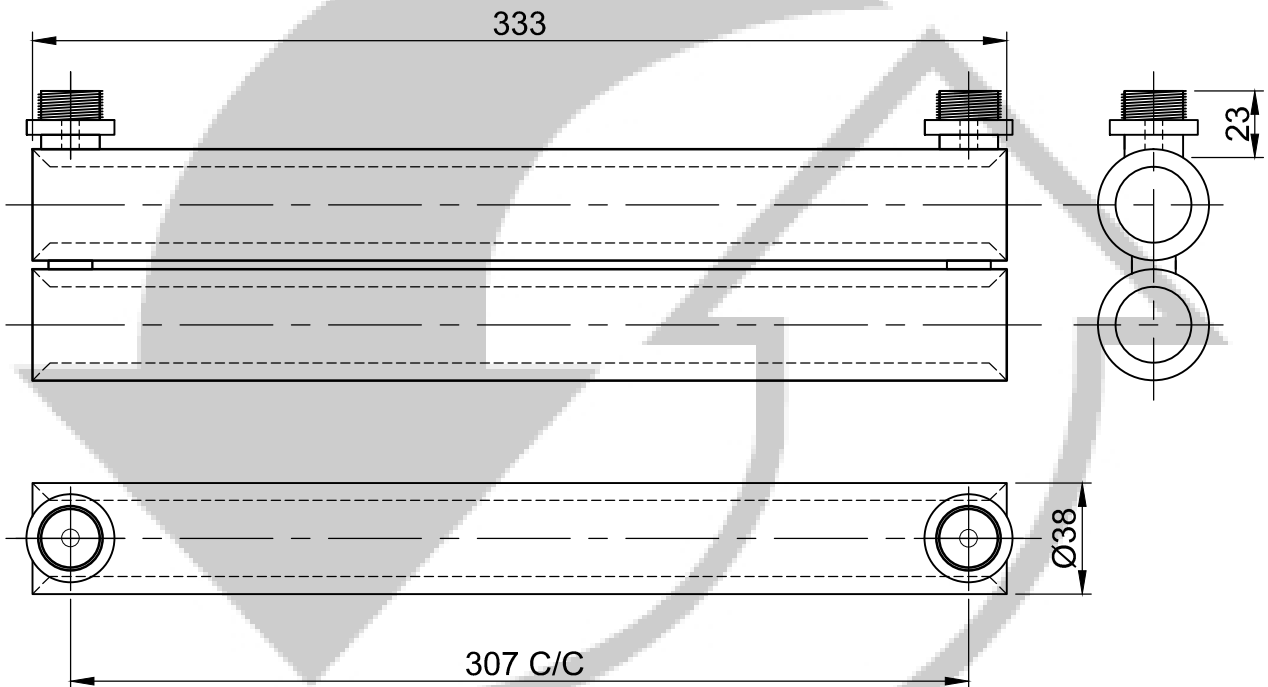

MODEL:FORD

PART NUMBER:TMOC333FOR1

# TRANSMISSION OILCOOLER-HYSTER

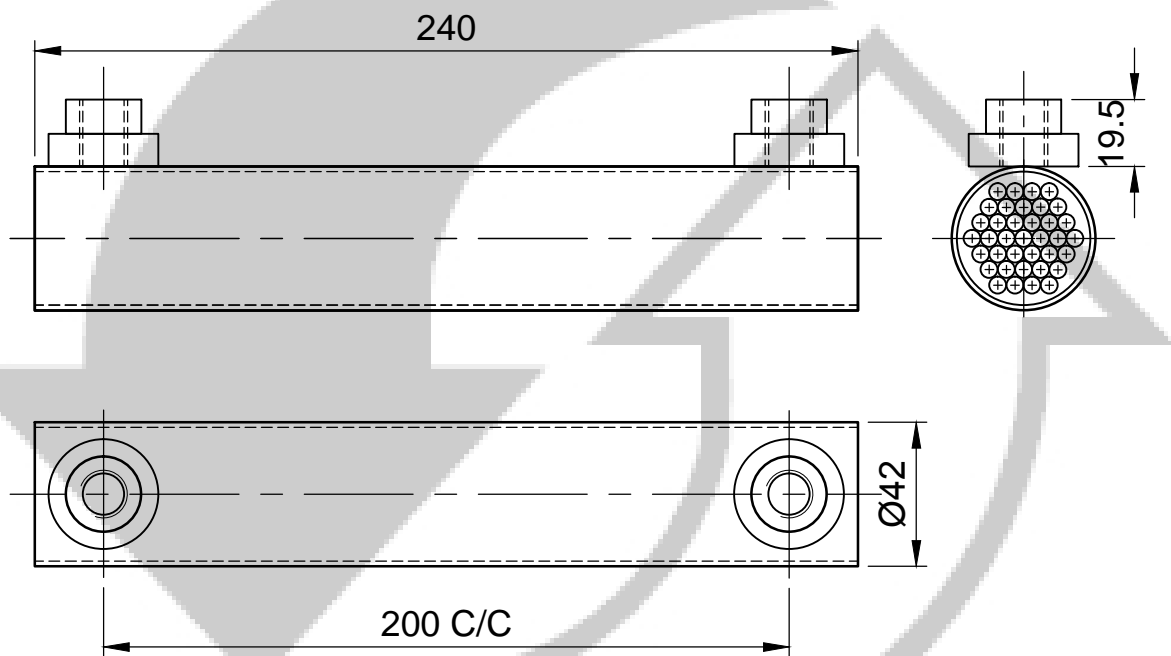

MODEL:HYSTER

PART NUMBER:TMOC240HYS1COM

# TRANSMISSION OILCOOLER-HYSTER

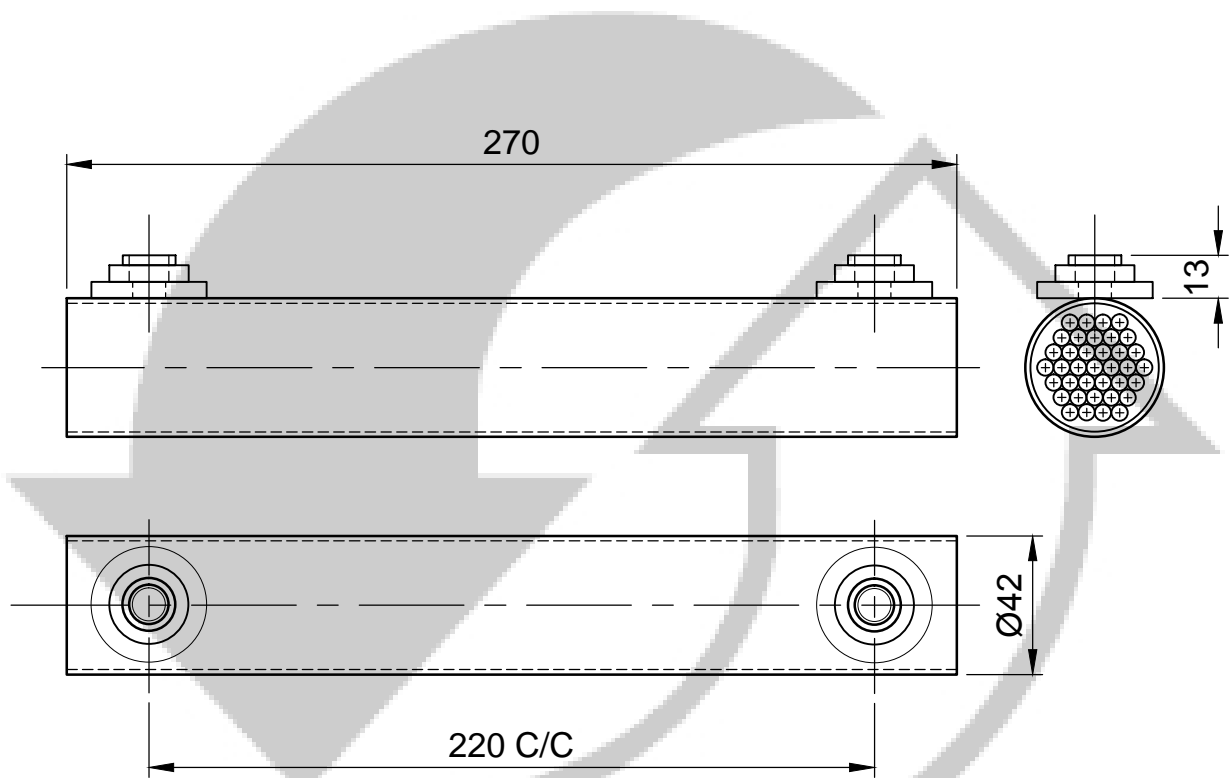

MODEL:HYSTER

PART NUMBER:TMOC270HYS1COM

# TRANSMISSION OILCOOLER-HYSTER

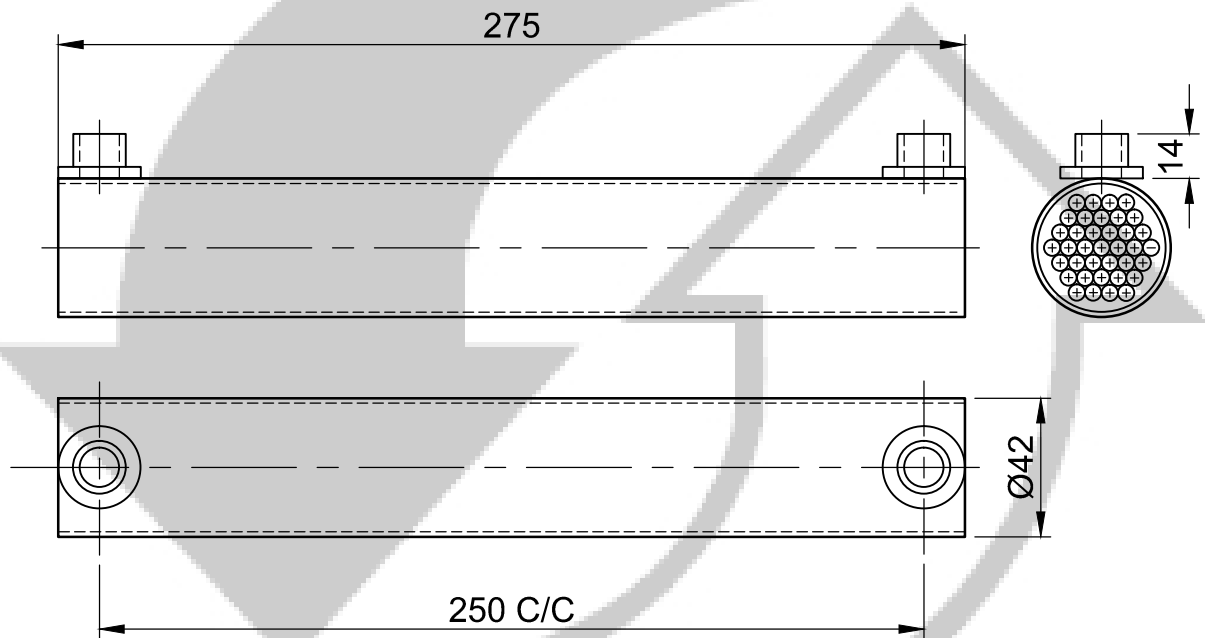

MODEL:HYSTER

PART NUMBER:TMOC275HYS1COM

# TRANSMISSION OILCOOLER-HYSTER

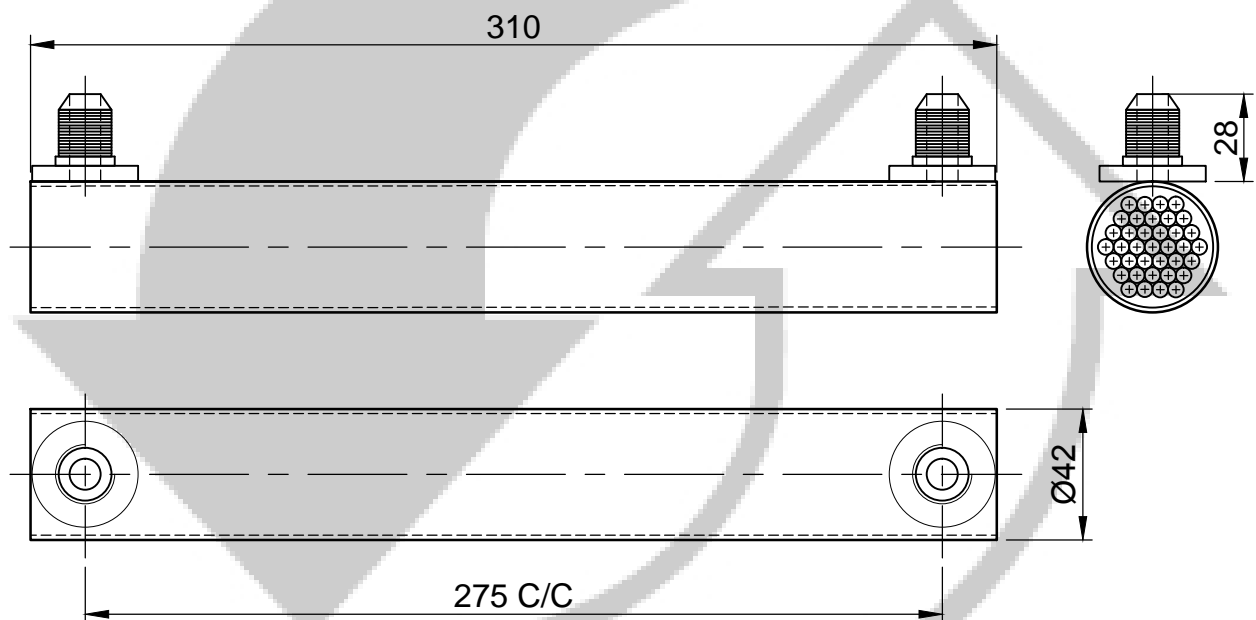

MODEL:HYSTER

PART NUMBER:TMOC310HYS1COM



# TRANSMISSION OILCOOLER-HYSTER

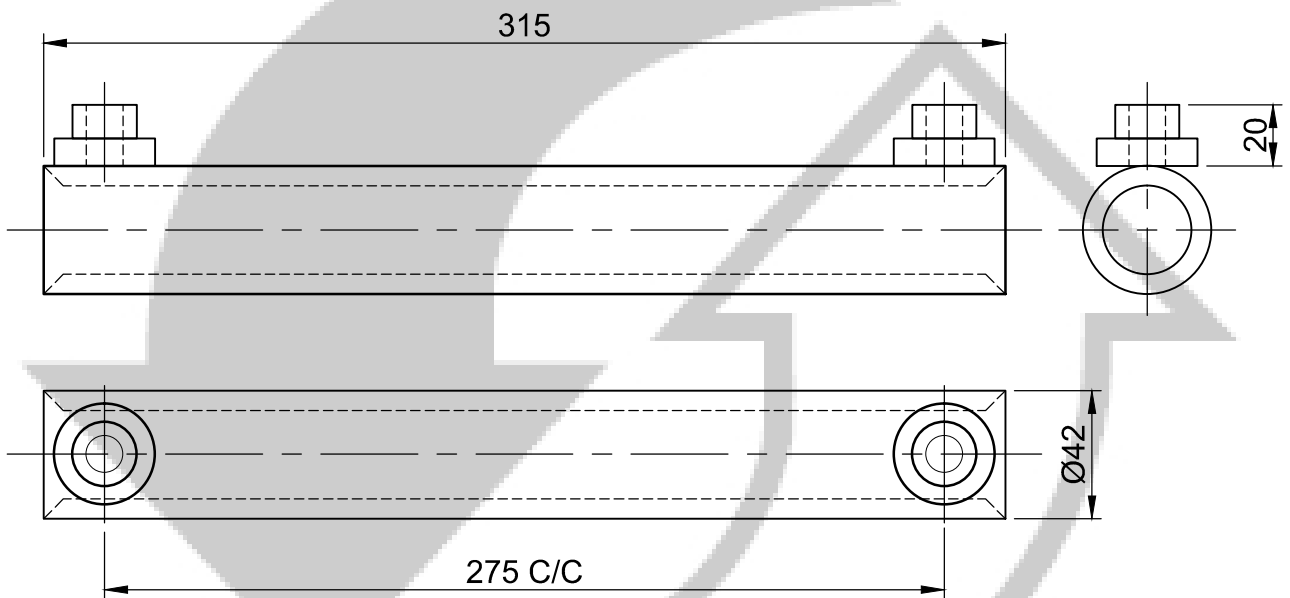

MODEL:HYSTER

PART NUMBER:TMOC-DB315HYS1COM

# TRANSMISSION OILCOOLER-HYSTER

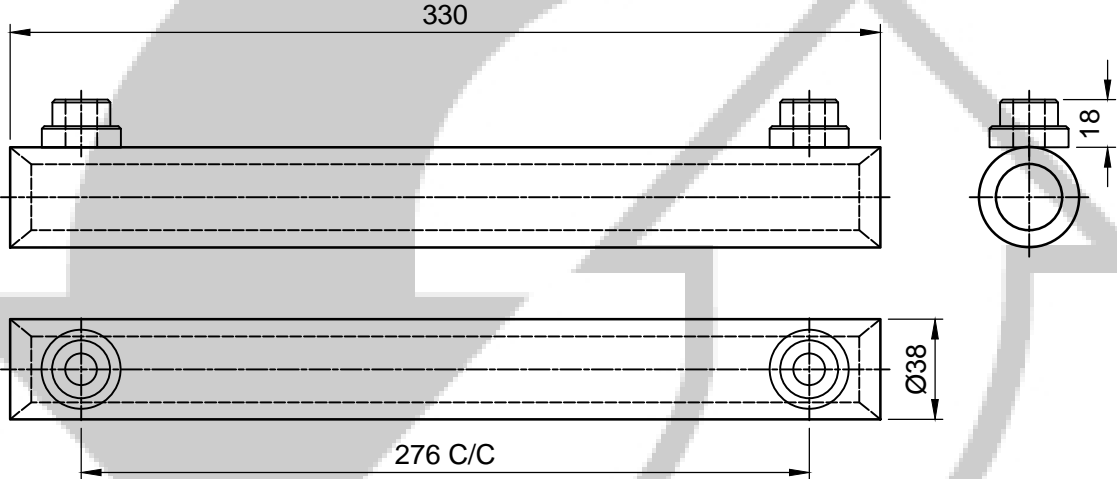

MODEL:HYSTER

PART NUMBER:TMOC330HYS1COM

# TRANSMISSION OILCOOLER-HYSTER

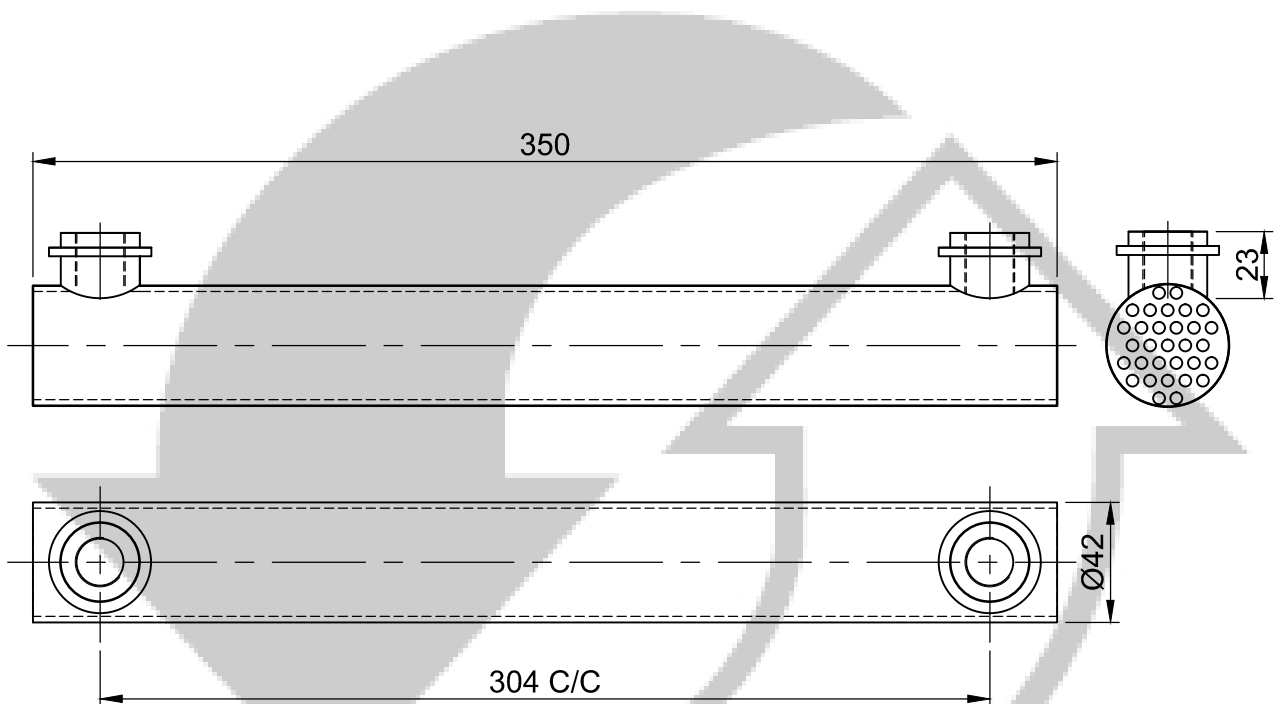

MODEL:HYSTER

PART NUMBER:TMOC350HYS1COM

# TRANSMISSION OILCOOLER-HYSTER

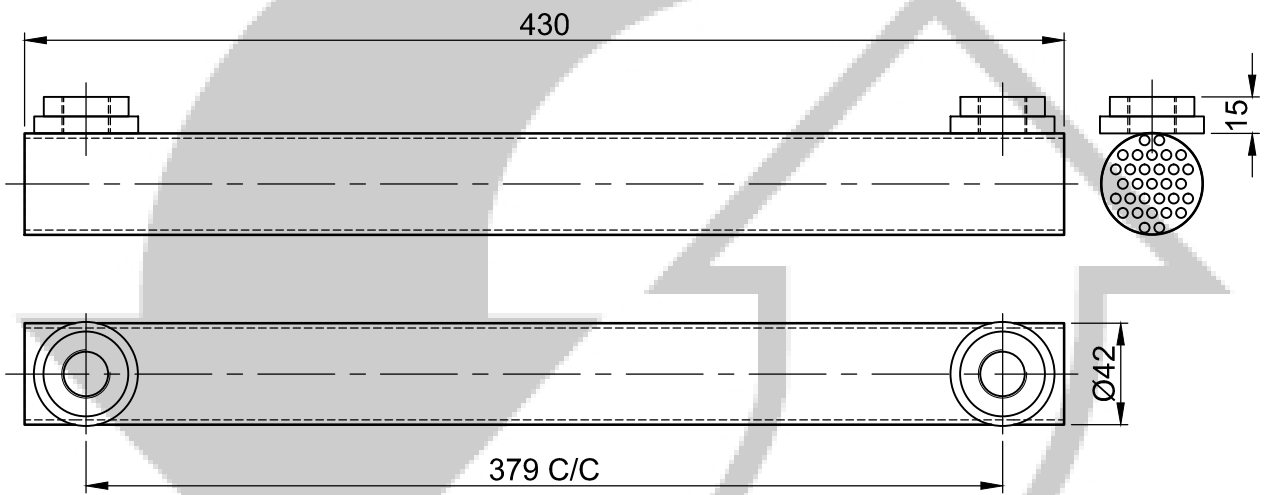

MODEL:HYSTER

PART NUMBER:TMOC430HYS1COM

# TRANSMISSION OILCOOLER-LAND ROVER

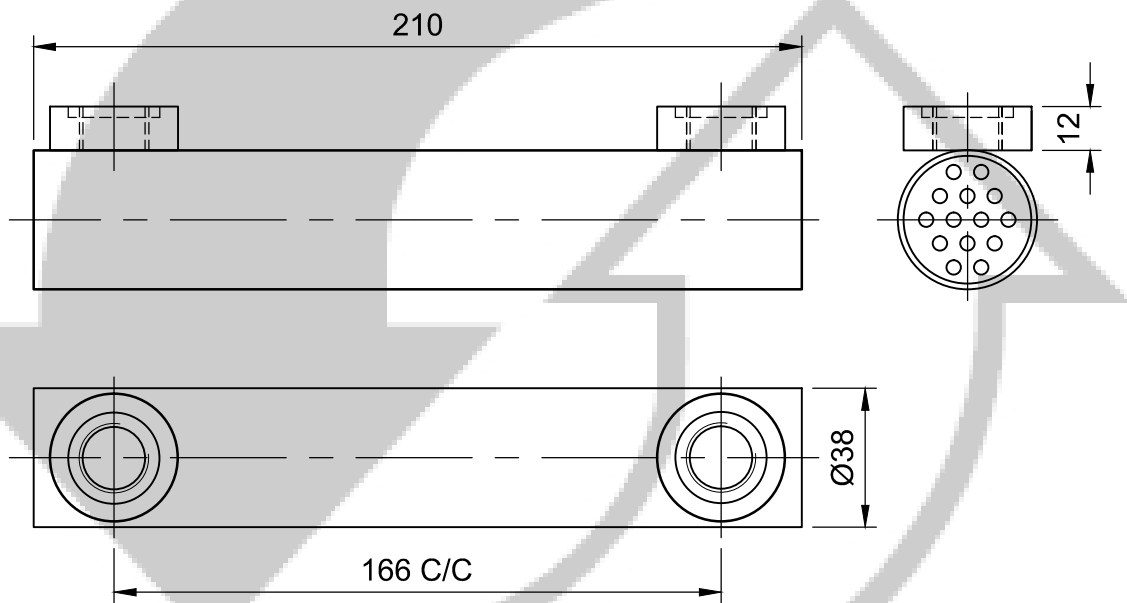

MODEL:LAND ROVER

PART NUMBER:TMOC-210LRO1COM

# TRANSMISSION OILCOOLER-MAN

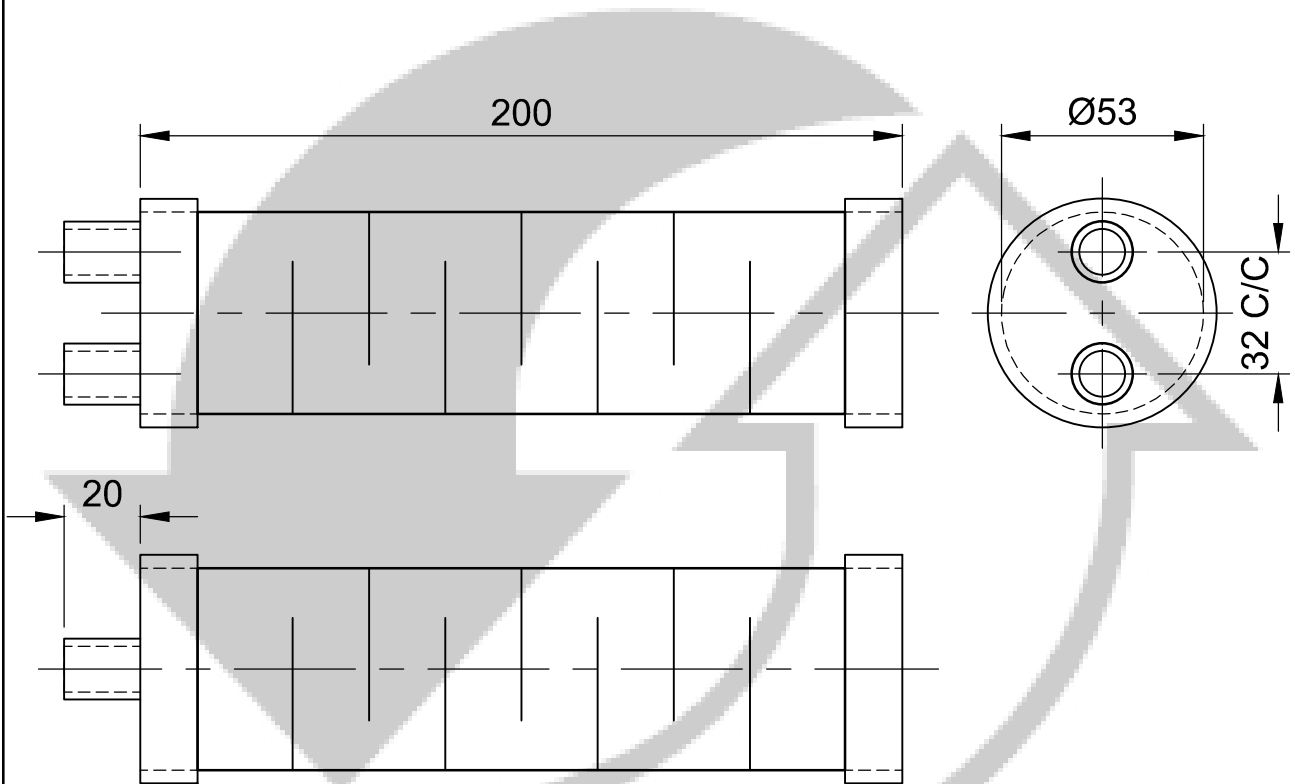

MODEL:MAN

PART NUMBER:TMOC-200MAN1COM

# TRANSMISSION OILCOOLER-MERCEDES BENZ

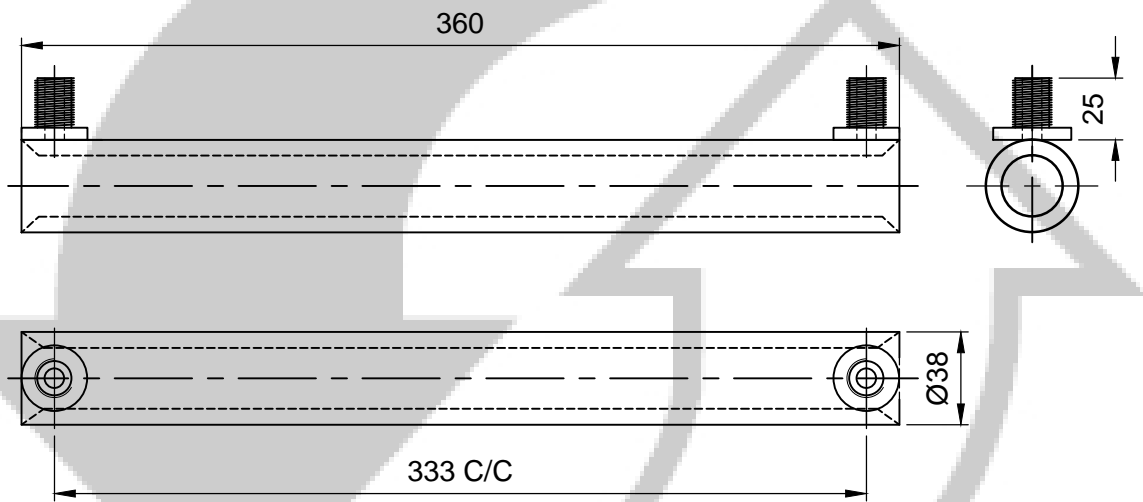

MODEL:MERCEDES BENZ

PART NUMBER:TMOC-DB360MER

# TRANSMISSION OILCOOLER-MERCEDES BENZ

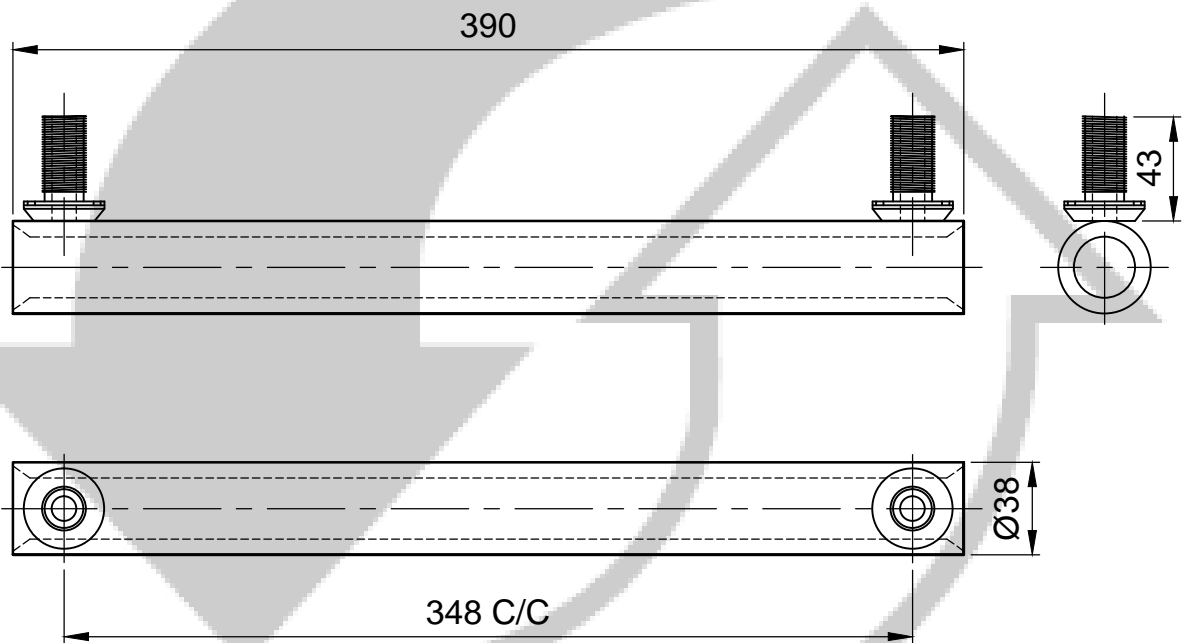

MODEL:MERCEDES BENZ

PART NUMBER:TMOC-DB390MER SCREW ON



# TRANSMISSION OILCOOLER-MERCEDES BENZ

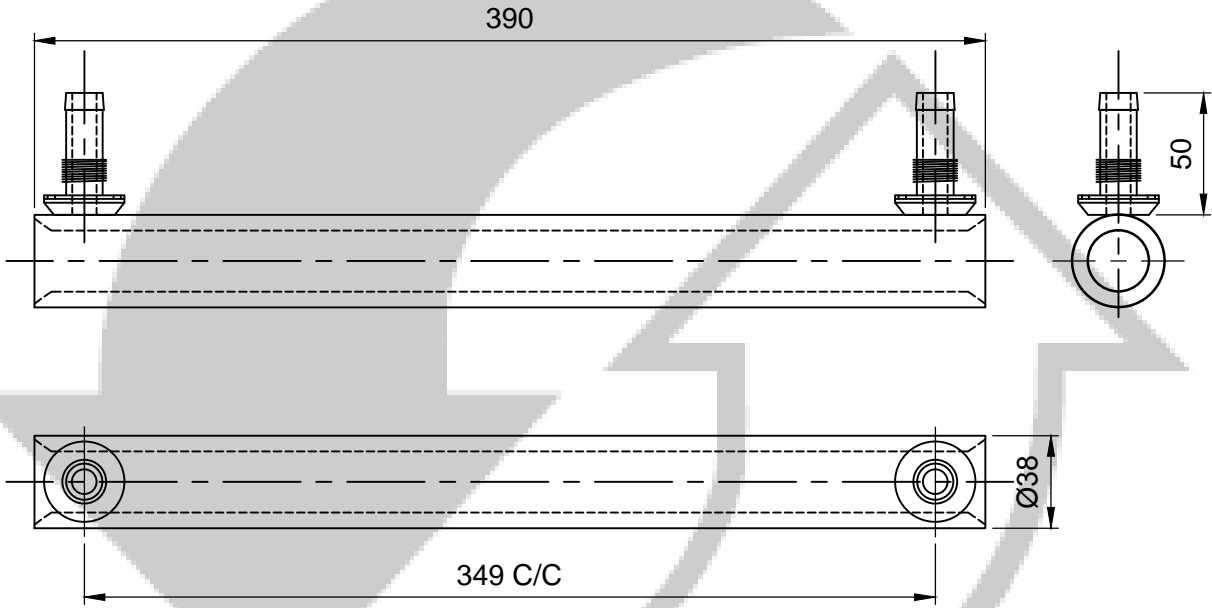

MODEL:MERCEDES BENZ

PART NUMBER:TMOC-DB390MER CLIP-ON

# TRANSMISSION OILCOOLER-MERCEDES BENZ

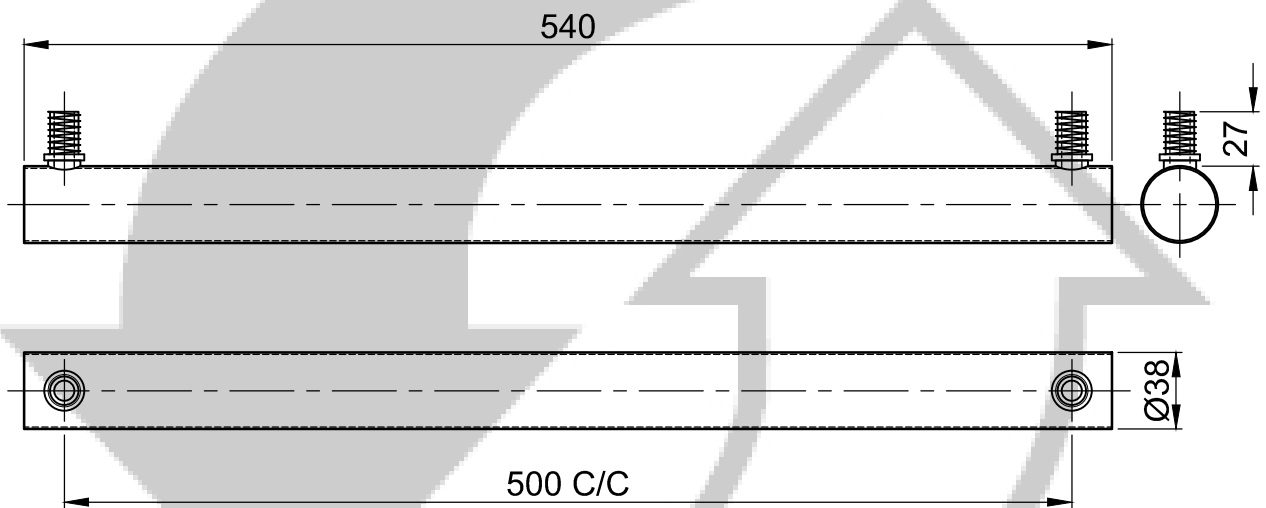

MODEL:MERCEDES BENZ\_ACTROS

PART NUMBER:TMOC-DB540MER1COM